



Microbiological Control

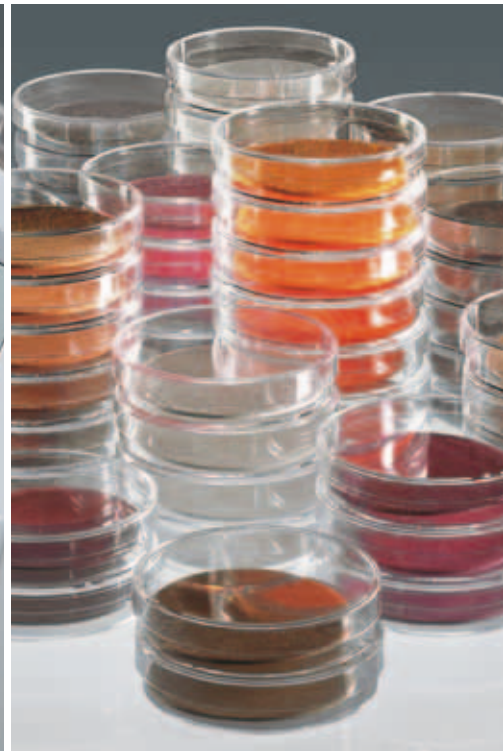
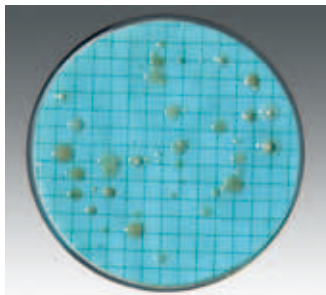

Table of Contents

Microbiological Quality Control	4	Microsart® @filter 100 and 250	33
Air Monitoring		Microsart® Funnel 100 and 250	35
MD8 airscan®	6	Biosart® 250 Funnels	37
AirPort MD8	7	Combisart® Systems	38
Gelatine Membranes	8	Microsart® Combi.jet	42
BACTair™ - Big Impact	9	How to Set Up a Vacuum Filtration System	44
Accessories for MD8 devices	10	Traditional Filter Holders	47
Colony Counting		Accessories	50
Gridded Membranes	12	School Kit	58
Microsart® e.motion	14	Sterility Testing	
Gridded Membranes	16	Sterisart® Universal Pump	59
Membranes without Grid	20	Sterisart® NF	60
Hydrophobic Edged Membranes	22	Reusable System	64
Nutrient Pad Sets	24	Services and Trainings	
Culture Media and Absorbent Pads	28	CONFIDENCE® Validation Services	66
Biosart® 100 Monitors	30	EXPAND® Trainings and Seminars	67
Biosart® 100 Nutrient Media	32	Chemical Compatibility	68

Microbiological Quality Control



Colony counting

Quantitative and reproducible detection of trace contamination or infection as well as the capability of performing efficient, cost-effective testing procedures under routine conditions are the requirements placed on a practical microbiological testing method. The membrane filter method optimally meets these requirements, and Sartorius Stedim Biotech offers the ideal range of filters and equipment to carry out this method.



In the standard membrane filter method, a membrane filter with the appropriate pore size is placed in a filter holder and the sample is filtered. Any microorganisms present in the sample are retained by the pore structure on the surface of the membrane filter. The membrane filter is then placed on an appropriate culture medium and incubated to detect these microbes. During incubation, the exchange of nutrients and metabolites takes place through the pore system of the membrane filter. The colonies that develop during incubation on the membrane filter surface are then counted and related to the filtered sample volume.

Sartorius Stedim Biotech specifically manufactures **individually packaged gridded membrane filters** for this application. These are ready to use and strictly quality controlled for colony growth.

Microsart® – The product family for innovative colony counting

The Microsart® product family consists of all the most recent products from SSB for microbiological analysis, which are especially characterized by innovation and clever design. Simple handling on less working area in comparison to conventional products that's it where Microsart® products have always stood out.

- Easy membrane removal
- Easy funnel removal
- All consumables are ready-to-use
- The hardware is intelligent and functional in design

The fully automated Microsart® e.motion membrane filter dispenser releases gridded membranes from their individual, specially developed and sterile packaging that does

not require any interleaving paper. Moreover, Sartorius Stedim Biotech also offers individually, sterile-packaged membrane filters in easy-to-open envelopes. Each one is clearly labeled with the product identification and lot number. Membranes with a 0.45 µm pore size are used on a standard basis for microbiological analysis.

Sartorius Stedim Biotech additionally supplies special membrane versions known as high-flow membranes. They deliver 30% higher flow rates compared with conventional 0.45 µm pore size membranes. The specially designed pore structures of 0.45 µm pore size membranes enable faster filtration runs thanks to their high flow rate performance and throughput. Especially *E. coli* shows best growth promotion on High Flow Membranes. Just like every lot of Sartorius Stedim Biotech 0.45 µm membrane filters, the special high flow versions are tested and released in compliance with ISO 7704.

Microsart® @vance® – Advance your microbiological control of Pharma-Biotech products

A new product line within the successful Microsart® product family is aimed directly at microbiological applications in the pharmaceutical and biotech industry: Microsart® @vance®. @vance® stands for even more progress and intelligent design, enhanced safety and thus more reliable results. Following the trend of using single-use products, these products are delivered sterile, ready-to-use and can be disposed of in an environmentally friendly manner. The new Microsart® @vance® product line is being launched with the Microsart® @filter 100 and 250 filter units, a ready-to-use combination funnel and gridded membrane in one unit. The process of producing pharmaceuticals and bringing new drugs to the market is becoming an increasingly costly business. The pharmaceutical and biotech industries are driven by the need to optimize their work flows and increase efficiency without compromising their level of safety. Microsart® @filter not only saves time and labor costs but minimizes the risk of secondary contamination – that's advanced colony counting by Sartorius Stedim Biotech.

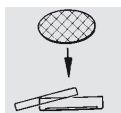

Nutrient Pad Sets:
Page 24



Microsart® e.motion
Membrane filter dispenser:
Page 14



Individually packaged,
gridded membrane filters:
Page 12



Microsart® @filter:
Page 33

Nutrient Pad Sets (NPS) provide added convenience. These are dehydrated culture media that are already individually inserted in a petri dish and sterilized. After they have been moistened with 3.0–3.5 ml of demineralized, sterile water, they are ready to use immediately. To find out which colonies typically grow on which NPS, please refer to page 24. Our wide array of culture media covers all the types needed in the food and beverage industry and in the pharmaceutical industry as well as for water analysis.

NPS are continuously enhanced as part of our development program to adapt our products to changing application requirements. Besides the new NPS types, we also offer Nutrient Pads in a new packaging design. The standard NPS box contains 100 sterile Nutrient Pads, each of which is individually inserted in a petri dish and sterilized. Ten each of these petri dishes are sealed in an aluminum bag. This special packaging in bags protects the sensitive formula constituents of the Nutrient Pad from fluctuations in humidity and temperature during transportation and storage. As a result, it guarantees the high quality of our NPS throughout their entire shelf life up to 24 months.

And this is precisely what makes the Sartorius Stedim Biotech Nutrient Pads Sets so unique: No other ready-to-use culture media around the globe assure such consistently high quality and reproducible results for up to 24 months.

Other bacteriological water tests

A procedure for collecting Legionella organisms specifies polyamide membranes (diameter 142 mm), of the pore size 0.2 µm or 0.45 µm.

For isolation of bacteriophages from water, Sartocon cross-flow filter cassettes with polyether sulfone membrane (100,000 MWCO) deliver excellent results.

Airborne bacteria and viruses

Gelatin membrane filters are routinely used for quantitative sampling of airborne

microbes in cleanroom and isolator monitoring. In addition, their effectiveness in collecting the smallest airborne viruses and bacteriophages has been proven. The reason: Gelatin appears to have a protective effect on the viruses collected and can be dissolved in buffer or a different medium for subsequent identification of the type of virus (page 8).

Gelatin membrane filters can also be used for routine monitoring of bacteriophages in the ambient air of dairies.

For faster and more convenient filtration of samples

Sterile single-use funnels and preassembled Monitors can be used in place of stainless steel funnels and vacuum filters holders.

Biosart® 250 Funnels

The 250-ml Biosart® funnels eliminate time-consuming sterilization of one sample to the next. The large inner diameter of the funnel base ensures exceptionally fast filtration runs (page 37).

Biosart® 100 Monitors

These complete Monitors featuring a 100-ml capacity are available with incorporated filters in a choice of different pore sizes, filter colors and diameters. The completely sterile units need to be used in conjunction with various culture media. After pouring in an appropriate liquid culture medium to wet the interior cellulose pad, the lid and base of the Monitor can be easily converted into a petri dish (page 30).

Combisart® Systems

The Combisart® design enables equipment and consumables to be optimally combined to meet specific needs. Each filter station on the multi-branch manifold has an air filter for sterile venting.

Sterisart®

Sterisart® enables sterility testing to be performed in a completely closed system according to international pharmacopeias.

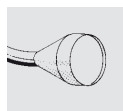

Gelatin membrane filters: Page 8



Biosart® 250 Funnels: Page 37



Biosart® 100 Monitors: Page 30



Combisart® Page 38

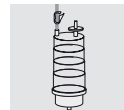

Sterisart® Page 59

Air Sampler for Critical Applications



The system consists of the MD8 airscan[®] air sampler and disposable gelatine filter units. The system is routinely used for the quantitative detection of air-borne organisms, mainly at filling lines in sterile areas of class A (classification according to "EU Guide for GMP"), isolators, or blow-fill-seal machines.

The exceptionally high air flow rate of 8 m³/h enables isokinetic sampling at flow rates that are usual in laminar flow as well as filtration of 1 m³ air very quickly (less than 8 minutes). The filter unit can be placed separately from the air sampler for remote sampling.

The MD8 airscan[®] air sampler allows to adjust selectively and easily air flow rate and sample removal speed. By means of a specially developed calibration unit (see accessories), the user can calibrate the MD8 airscan[®] locally, e.g. within the scope of validation steps.

After removing the sample, the gelatine filter can be placed directly on the agar culture medium for incubation and colony growth.

Specifications

Specifications for the MD8 airscan[®] air sampler

Air flow rate	2.0 m ³ /h – 8 m ³ /h adjustable in 100-liter steps
Timer	1–99 minutes, adjustable in 1-minute steps
Max. deviation	±5% in a temperature range of 15°–35°C
Noise level	For gelatine membrane filters, max. 62 dB (A)
Weight	Approx. 6.5 kg
Dimensions (L×W×H)	375×242×228 mm
Correction of the air flow rate setting	When the entered air flow rate cannot be attained, the display shows the max. attainable flow rate for a corresponding new setting below this value.
Inclusive filter holder	Sartorius Stedim Order No. 17655 Fisher Scientific Order No. 14-555-880 (Gelatine disc filters)

Ordering information for the MD8 airscan[®] air sampler

Sartorius Stedim Order No.	Fisher Scientific Order No.	
16747-US	14-555-866	MD8 airscan [®] air sampler, 115 V, 60 Hz

Each version can be switched from 50 to 60 Hz and back.

Accessories for the MD8 airscan[®] air sampler

Sartorius Stedim Order No.	Fisher Scientific Order No.	
17801	14-555-875	Holder for disposable gelatine filter units

Ordering information for consumables

Disposable gelatine units, sterile, pack of 10

Sartorius Stedim Order No.	Fisher Scientific Order No.	
17528--80----ACD	14-555-666	Individually packed in 1 polyethylene bag each
17528--80----BZD	14-555-667	Individually packed in 3 polyethylene bags each
17528--80----VPD	14-555-668	Individually packed in 3 polyethylene bags each, but label on innermost bag

AirPort MD8 Battery-Powered Portable Air Sampler



AirPort MD8 is the air sampler for the pharmaceutical industry, the biotechnology, the food and beverage industry, for hospitals' environmental care and for work safety.

AirPort MD8 offers the following benefits

- Battery-powered and portable for universal use.
- Battery power level clearly indicated so constant performance during sampling is guaranteed.
- Ergonomic design and easy to clean.

- Flexible adjustment possibilities of the volume flow and the sample volume.
- User-friendly prompting with the option of four languages; English, French, German and Spanish.
- Parameters last used stored even after automatic shut-off.
- The device can be calibrated locally.

For guaranteeing reliable and exact measurement results AirPort MD8 uses the gelatine membrane filter method or the impaction method with BACTair™.

Specifications

Specifications for AirPort MD8

Volume flow regulation	By an integrated impeller wheel.
Volume flow adjustable	30 l/min., 40 l/min., 50 l/min. and 125 l/min.
Fixed given sample volumes	25, 50, 100, 250, 500, 750 and 1000 liters. In addition, the sample volume can be chosen manually in 5-liter steps.
Operational life with one battery charge	Approx. 4.5 hours for 50 l/min
Noise level	For gelatine membrane filters 48 dB (A)
Weight	Approx. 2.5 kg
Dimensions (L×W×H)	300×135×165 mm
Inclusive adapter	Sartorius Stedim Order No. 17801 Fisher Scientific Order No. 14-555-875 (for disposable gelatine filter units) Sartorius Stedim Order No. 17803 Fisher Scientific Order No. 14-555-876 (for BACTair™ Plates)

Power supply

Battery	NiMH 16.8 Volt/3800 mAh
Battery charger input	100–240 V/47–63 Hz/600 mA
Battery charger output	24 V/1000 mA
Charging time	Approx. 4.5 hours for empty battery

Ordering information for the AirPort MD8

Sartorius Stedim Order No.	Fisher Scientific Order No.	
16757	14-555-867	AirPort MD8, complete with two adapters (Sartorius Stedim Order No. 17801 and 17803 Fisher Scientific Order No. 14-555-875 and 14-555-876) and battery charger (Sartorius Stedim Order No. 69898525 Fisher Scientific Order No. TBD).

Accessories and replacement parts for the AirPort MD8

Sartorius Stedim Order No.	Fisher Scientific Order No.	
17803	14-555-876	Adapter for BACTair™ on the AirPort MD8 air sampler
17801	14-555-875	Holder for disposable gelatine filter units
69898525	TBD	Battery charger

Ordering information for consumables

Please refer to the following pages.

Special brochures available on request. Order no. SM-1502-e and SM-4023-e

Gelatine Membrane Filters

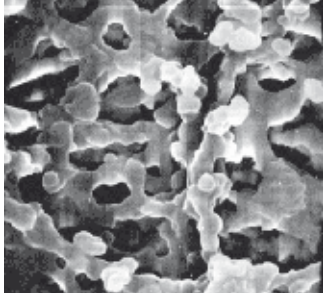

Gelatine filters in conjunction with the MD8 air samplers (gelatine filter method) are used for collecting of airborne microbes and viruses. Gelatine filter disposables are individually packed, pre-sterilized and ready-to-connect units, each consisting of a gelatine membrane filter and a holder. Gelatine membrane filters are still available as filter discs, suitable for the filter holder Sartorius Stedim Order No. 17655 | Fisher Scientific Order No. 14-555-880 (80 mm diameter) supplied with the MD8 airscan® air samplers, as well as in smaller diameters.

Gelatine filters in conjunction with the MD8 air samplers offer the following features and benefits:

- "Absolute" retention rate (99.9995% for Bac. sub. niger spores, 99.94% for T3 phages).
- The filter maintains the viability of collected microorganisms for a relevant and meaningful sampling time.
- Gelatine filters are completely water-soluble. Therefore, microbes in one sample can be cultivated in | on different nutrient media or low and high bacteria counts can be measured. The sample is not affected by inhibitors.
- The solubility of the gelatine filter is a prerequisite for virus sampling.

Specifications

Specifications of gelatine filters

Gelatine filters	Water soluble, pore size 3 µm, 80 mm diameter, thickness approx. 250 µm
Thermal resistance	Max. 60°C
Air flow rate	Approx. 2.7 l/min./cm ² at ΔP = 0.05 bar
Retention rates	1. Bac. subtilis niger spores 99.9995% at 0.25 m/s inlet velocity. 2. Coli phages: phage T1, 99.9% at 0.3 m/s inlet velocity and 50% rel. air humidity. Phage T3, 99.94% at 0.3 m/s inlet velocity and 80% rel. humidity.
Filtration area	38.5 cm ²
Conditions for use	Room temperature, max. 30°C, max. air humidity 85%
Sterilization	Supplied pre-sterilized by gamma irradiation

Disposable gelatine units, sterile, pack of 10

Sartorius Stedim Order No.	Fisher Scientific Order No.	
17528--80----ACD	14-555-666	Individually packed in 1 polyethylene bag each
17528--80----BZD	14-555-667	Individually packed in 3 polyethylene bags each
17528--80----VPD	14-555-668	Individually packed in 3 polyethylene bags each, but label on innermost bag

Gelatine disc filter, sterile, sealed in units of five each in a polyethylene bag

Sartorius Stedim Order No.	Fisher Scientific Order No.	Diameter	Package size
12602--80----ALK	14-555-664	80 mm	50
12602--50----ALN	TBD	50 mm	100
12602--50----ALK	14-555-663	50 mm	50
12602--47----ALN	14-555-662	47 mm	100
12602--47----ALK	14-555-661	47 mm	50
12602--37----ALK	14-555-660	37 mm	50

Special brochure available on request. Order no. SM-3011-e

BACTair™ – Big Impact. Microbiological Air Monitoring by the Impaction Method



A new developed system for sampling airborne organisms that allows impaction onto culture media plates, where the plates function directly as collection heads. This means that the collection properties are integrated right into the culture media plates. Metal sieve plates or metal collection heads with slots, which have to be sterilized for routine samplings on a regular basis, are eliminated. Now, non-sterile sieves or slots have become a thing of the past.

The geometry of the culture medium plate and the 400 holes in the sieve plate yield exceptional sampling efficiency, which is generally higher than that of other impaction samplers.

This new method uses the AirPort MD8 air sampler to draw the air stream over the BACTair™ Culture Media Plates. BACTair™ is ready-to-connect to the AirPort MD8.

BACTair™ offers the following benefits

- Individually, sterile packaged
- Integrated disposable sieve
- Pre-filled with agar media
- Samples 1 m³ in just 8 min
- Optimized geometry

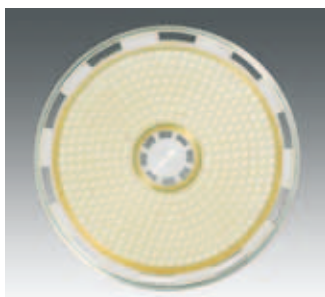

Specifications

Specifications for BACTair™

Material	Polystyrene
Dimensions	116×24 mm
Number of impaction holes	400 holes, Ø 0.47 mm each
High retention of particles	> 0.65 µm
Sterilization	Gamma irradiation

BACTair™ Culture Media Plates with Agar, 110 mm, individually, sterile packaged, 10 units

Sartorius Stedim Order No.	Fisher Scientific Order No.	Determination of	Medium Type
14320-110----ACD	14-555-736	Total Count	Tryptic Soy Agar (TSA)
14321-110----ACD	14-555-737	Yeasts and molds	Sabouraud Agar (acc. USP)

Other BACTair™ Culture Media types on request.

Air Sampler

16757	14-555-867	AirPort MD8 Air Sampler for BACTair™ incl. charger
-------	------------	--

Accessories

17803	14-555-876	Adapter for BACTair™ on the AirPort MD8 air sampler
1ZPX-D0002	14-555-872	Covers for BACTair™ Culture Media Plates, 10×2 units individually, sterile packaged
14301-110-----K	14-555-874	BACTair™ Plates, sterile, without media

Special brochures are available on request. Order no. SM-4023-e and SL-2047-e

Accessories for the MD8 Air Samplers



Calibration unit

The user can calibrate the MD8 airscan[®] and AirPort MD8 directly on the job by means of the calibration unit*.

This is absolutely necessary above all within the scope of validation steps, for which it is important that the shown air flow rate (desired value at the MD8) corresponds to the actual air amount (actual value at the calibration device). The calibration unit is supplied complete with battery charger | power supply unit (specific for the country in which it is used), filter holder, connectors set and connection tube (PVC, 2 m).

* Alternatively, a maintenance agreement can be signed. Within the scope of the contractual services, Sartorius Stedim Biotech technicians will carry out a calibration of the MD8 at regular intervals

Specifications for calibration unit

Dimensions	Length, 300 mm (without filter holder), Width, 390 mm with handles Height, 182 mm min., 200 mm max. (adjustable feet)
Connectors	Quick locks (bayonet principle)
Operational life with full battery	Approx. 4 hours
Charge time for empty battery	Approx. 10 hours
Measuring range	1–16 m ³ /h
Max. error	1–16 m ³ /h, ±2%
Type of protection	IP 40
Allowable ambient temperature	Min. 0°C, max. 40°C
Weight	Approx. 11 kg

Special brochure available on request.
Order no. SL-2028-e

Tubing and connectors set

If the disposable gelatine filter unit is not placed directly at the MD8 airscan[®], but at a distance from it, a flexible plastic hose (2 m or 5 m), a connectors set and, if not available, a holder (Sartorius Stedim Order No. tripod 16970, double socket 16976, clamp 17037 | Fisher Scientific Order No. tripod TBD, double socket TBD, clamp TBD) are necessary for the connection between filter and MD8 airscan[®]. The autoclavable silicone hose is used instead of the flexible plastic hose, if the MD8 airscan[®] has to be used in sterile rooms, operating rooms, isolators, blow-fill-seal machines, etc. With this hose attached to the air outlet connector (exhaust), the waste air can be led off into another room.

Case

A stable case for the transport and the storage of a MD8 airscan[®], incl. accessories.

Aluminum stack

It consists of a middle part, 10 numbered filter holders and 2 end caps. The stack is first sterilized (by 180°C dry heat, 2 h), and then equipped with the filters under sterile conditions (LF cleanbench). The prepared filter holders are put on one side of the middle part. After removing the sample, the inserted filter holders are put on the other side of the middle part, so that used and unused filter holders are separated from each other.

Accessories for isolator application

For the monitoring of isolators with MD8 airscan[®], we recommend using stainless steel accessories such as adapters Sartorius Stedim Order No. 17016 (DN25) or 17030 (DN30) | Fisher Scientific Order No. 14-555-890 (DN25) or 14-555-869 (DN30), clamps Sartorius Stedim Order No. 17033 | Fisher Scientific Order No. 14-555-891 for sanitary flanges, connector Sartorius Stedim Order No. 17659---001 or 17659---003 | Fisher Scientific Order No. TBD or 14-555-911 (for tri clamp) and the filter holder for gelatine filter disposables Sartorius Stedim Order No. 17801---001 | Fisher Scientific Order No. TBD as well as a Sartofluor capsule with PTFE membrane and sanitary flange inlet and outlet, for sterile air filtration inserted between the MD8 airscan[®] and isolator. This construction makes it possible that the MD8 air sampler remains outside the critical work area (the barrier function between different clean-room classes is maintained).

Accessories for remote control function

Users of the MD8 airscan® now have the possibility of operating this air sampler from a distance, using either of two remote control configurations:

- a) Via a PC (with Microsoft 95/98 or higher) with MD8 airscan® dialog system and cable connection to the MD8 airscan® (Sartorius Stedim Order No. 1ZE---0004 | Fisher Scientific Order No. 14-555-877).
- b) Via a PLC interface unit (Sartorius Stedim Order No. 1ZE---0003 | Fisher Scientific Order No. TBD).

Gelatine membrane filter, 80 mm, sterile, pack of 50 for use with stack

Gelatine membrane filters are still available as 80 mm filter discs, suitable for the filter holder supplied with the MD8 airscan®. The filters are sterile-supplied, but the filter holders have to be sterilized by dry heat (180°C, 2h) and then equipped with the filters under sterile conditions. For performing routine check-ups, a stack is recommended in this case.

Further consumables for air monitoring

If gelatine filters cannot be used (high humidity, high temperature), it is recommended to use cellulose nitrate filters.

Accessories for the MD8 air samplers

Sartorius Stedim Order No.	Fisher Scientific Order No.	
16756	14-555-868	Calibration unit for the MD8 air samplers
17208	14-555-873	Case for MD8 airscan®
17656	14-555-878	Aluminum stack for MD8 air samplers

Replacement parts for the stack

Sartorius Stedim Order No.	Fisher Scientific Order No.	
17655	14-555-880	Individual filter holders for gelatine filter type Sartorius Stedim Order No. 12602--80----ALK Fisher Scientific Order No. 14-555-664
17660	14-555-912	Middle part
17661	TBD	End cap

Tubing and connectors set

Sartorius Stedim Order No.	Fisher Scientific Order No.	
17085	14-555-870	Flexible PVC hose with reinforced ends (2 m)
17088	14-555-871	Flexible PVC hose with reinforced ends (5 m)
17662	14-555-913	Silicone tubing, sterilizable (1 m, state length required)
17657	14-555-879	Set of connectors (consisting of Sartorius Stedim Order No. 17658 and 17659 Fisher Scientific Order No. 14-555-909 and 14-555-910), aluminum
17658	14-555-909	Connector (air sampler inlet to flexible hose), aluminum
17659	14-555-910	Connector (flexible hose to filter holder adapter), aluminum

Accessories for isolator application

17016	14-555-890	Adapter (DN 25 hose barb to 1" – 1 1/2" sanitary flange) to connect MD8 airscan® to an isolator via silicone tubing and a filter capsule, stainless steel
17030	14-555-869	Adapter (DN 30 hose barb to 1" – 1 1/2" sanitary flange) to connect MD8 airscan® to an isolator via flexible PVC hose and filter capsule, stainless steel
17033	14-555-891	Clamp for 1" – 1 1/2" sanitary flanges, stainless steel
17659---001	TBD	Connector (flexible hose to filter holder adapter), hose nipple, stainless steel
17659---003	14-555-911	Connector (flexible hose to filter holder adapter), tri clamp, stainless steel
17801---001	TBD	Adapter for gelatine filter disposables, stainless steel
5185307TS-----SS	TBD	Sartofluor® MidiCap Capsule with PTFE membrane and sanitary flange inlet and outlet, for sterile air filtration inserted between the MD8 airscan® and isolator
5185307T9--SS--A	TBD	Sartofluor® MidiCap, PTFE single layer membrane, 0.2 µm sterilizing grade, size 9, 1-1/2" sanitary flange I/O, pack of 4

Accessories for remote control function

1ZE---0003	TBD	Remote control (Interface) for MD8 airscan® designed for PLC units
1ZE---0004	14-555-877	Remote control for MD8 airscan® for use with PC (dialog system software)

Consumables used with stack

Gelatine disc filters, 3 µm pore size, 80 mm, 50 pieces/pack		
12602--80----ALK	14-555-664	Gelatine disc filter, sterile, sealed in units of five each in a polyethylene bag

Further consumables for air monitoring

Cellulose nitrate membrane filters, 80 mm diameter, 100 pieces/pack		
11404--80----ALN	14-555-591	Cellulose nitrate membrane filters, 0.8 µm, white with black grid, pre-sterilized in bags of 5
13004--80----ALN	14-555-618	Cellulose nitrate membrane filters, 0.8 µm, gray with white grid, pre-sterilized in bags of 5
11301--80----ALN	14-555-570	Cellulose nitrate membrane filters, 8 µm, white no grid, pre-sterilized in bags of 5

Gridded Membrane Filters from Cellulose Nitrate (Cellulose Ester) acc. to ISO Standards, Sterile and Individually Packaged, for Colony Counting



Sterile, individually packed filters have long become standard for routine microbiological quality control because of the user benefits they offer.

They are pre-sterilized and ready-to-use and save preparatory time. As they are individually packed, they avoid the possibility of contamination of remaining filters in opened packs and conform with GLP, having filter identification and lot number printed on each individual envelope.

The increasing demand on these filters required the construction of a new packaging machine with ultra-modern stamping. Each membrane is checked to ensure it is not damaged in any way, is positioned correctly with no slippage under the edge seal, has perfect grid printing and is free of particles. Each envelope is checked for readable lettering. Quality control par excellence!

These membrane filters are in accordance with the following norms: ISO 7704, ISO 7899-2, ISO 8199, ISO 9308-1 and ISO 16266. In addition to this they have been manufactured for use especially at the same time with Sartorius Stedim Biotech Nutrient Pads in accordance with the AFNOR (French Standards), the American Petroleum Institute, the American Society for Microbiology, the APHA Standard Methods, the Association of Official Analytical Chemists, the British Drinking Water Guideline, the British Standards, the DGHM (German Association of Hygiene and Microbiology), the DIN Guidelines (German Standards), the European Brewery Community, the European Drinking Water Guideline 98/83, the European Pharmacopoeia, the German Pharmacopoeia, the International Commission for Uniform Methods of Sugar Analysis, the International Dairy Federation, the International Fruit Juice Producers, the ISO Guidelines, the LMBG (German food law), the method described by Lanaridris & Lafon-Lafourcade, the method described in the journal of Food Protection, the method described in the journal of the Institute of Brewing, the methods of the Central European Brewery Commission, the MNO (Mineral|Table Water Guideline), the National Canners Association, the testing procedures for packaging stuff, the U.S. Environmental Protection Agency, the United States Pharmacopoeia, the US Department of Agriculture, the VLB (German Institute of Brewery), the Zentralblatt für Hygiene (Journal of Hygiene), the US Federal Drug Administration and Internal Standard Operation Procedures.

Specifications

The membrane filters

All membranes are made of cellulose nitrate, a material which assures effective retention with high flow rates and optimum colony growth. The printed grid with a size of 3.1 × 3.1 mm makes the counting easier, especially for higher bacteria counts and for microcolonies, but does not influence the growth. The various filter colors allow the best contrast to the colonies and particles.

High flow membranes

The standard membrane filter for microbiological analysis is an 0.45 µm filter. One special variant is the High Flow membrane. It provides 30% higher flow rates in comparison to traditional 0.45 µm membranes. The special pore structure of the new 0.45 µm HighFlow membrane filters allows shorter filtration times due to higher flow rates and throughputs. Especially E. coli shows best growth promotion on High Flow Membranes. As every Sartorius Stedim Biotech 0.45 µm membrane filter lot, these membranes are also tested and released according to ISO 7704.

Additional membrane filters

Cellulose nitrate (cellulose ester) membrane filters, gridded, non-sterile packaged (page 18).

Cellulose nitrate (cellulose ester) and cellulose acetate membrane filters, white, individually, sterile packaged (page 20).

Hydrophobic edge membranes are used mainly in the sterility testing of solutions containing antibiotics (page 22).

Microsart® e.motion Dispenser



Fully automated membrane filter dispenser for individually sterile cellulose nitrate filter discs.

The membrane filters are automatically removed from their sterile package – either in a touch-free mode via an optical sensor or at the touch of a button. A pedal switch can be optionally connected to the dispenser. Thanks to their new motorized traction roller, each filter is quickly and reliably dispensed. Membranes that accidentally slide out of their packaging or that even get damaged in the process are now problems of the past.

The controller specially developed for the Microsart® e.motion prevents unwanted dispensing of several membrane filters at a time – it's simple, "fail-safe," and fast.

The clear, compact design of the dispenser allows quick and easy cleaning. The Microsart® e.motion has an interface port available so that other sensor systems can be connected to control the dispenser. The dispenser's low weight makes it easy to transport. Both its functions and design are ideal, giving you the versatility and flexibility you need in your lab.

Applications

Membrane filters for colony counting, particle testing and microscopy

Some of the advantages you will benefit from when using the Microsart® e.motion dispenser:

- Fully automated membrane filter dispenser
- Works hands-free by an optical sensor
- Works by touch button
- Compact design
- Rapid and reliable transport due to sprocket feed roll technology
- Easy insertion of the filter band
- Easy-to-clean

Specifications of the Microsart® e.motion dispenser

Dimensions (L×H×W) in mm	204×213×165
Weight	2.9 kg
Operating voltage	110 V/230 V optional
Frequency	50–60 Hz
Max. power	Consumption 10 W
Dispensing speed	0.5 sec
Dispenser delay	5 sec
Certificates	CE Mark and EMC Directive, European Standards EN 50081-1 and -2, EN 50082-1 and -2, EN 61010

Order number for Microsart® e.motion dispenser

Sartorius Stedim Order No.	Fisher Scientific Order No.	
16712	14-555-785	Microsart® e.motion dispenser, fully automated membrane filter dispenser.
1ZE---0028	14-555-782	Pedal (foot switch) for Microsart® e.motion dispenser

Microsart® e.motion Membrane Filters

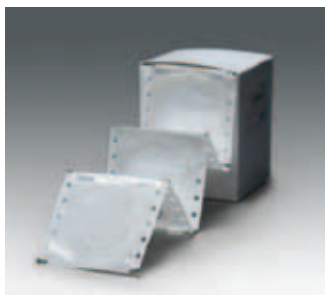

The membrane filter band specially designed for the Microsart® e.motion can be conveniently inserted, and changed easily and rapidly as needed, even without having to completely use up a complete package quantity. Each box contains 100 membrane filters individually sealed on a special pleated band, and is designed so that it is easy to open and seal for storage. Microsart® e.motion – reliable help in your lab.

Some of the advantages you will benefit from when using the Microsart® e.motion membrane filters:

- Outstanding recovery rates for microorganisms
- 0.45 µm are acc. to ISO 7704
- Multi-fit: Fits into various dispensers
- Protective paper-free
- Packaged on a special pleated band
- Product data are printed on
- High Flow membranes available
- Gamma irradiated, 25kGray

Specifications

Please refer to the membrane type: Cellulose nitrate (cellulose ester), gridded, individually, sterile packaged

Order numbers for Microsart® e.motion Membrane Filters
Diameter 47 mm or 50 mm, in pack of 3 × 100 membranes, individually, sterile packaged, without protective paper

	Sartorius Stedim Order No.	Fisher Scientific Order No.	
White black	11407Z-47----SCM	14-555-610	0.2 µm
White black	11407Z-50----SCM	TBD	0.2 µm
White black	114H6Z-47----SCM	14-555-613	0.45 µm High Flow
White black	114H6Z-50----SCM	TBD	0.45 µm High Flow
White black	11406Z-47----SCM	14-555-604	0.45 µm
White black	11406Z-50----SCM	14-555-605	0.45 µm
White black	11404Z-47----SCM	TBD	0.8 µm
White black	11403Z-47----SCM	TBD	1.2 µm
White black	11403Z-50----SCM	TBD	1.2 µm
White black	11402Z-47----SCM	14-555-580	3 µm
White green	139H6Z-47----SCM	14-555-658	0.45 µm High Flow
White green	13906Z-47----SCM	14-555-656	0.45 µm
White green	13906Z-50----SCM	TBD	0.45 µm
Green dark green	13806Z-47----SCM	14-555-650	0.45 µm
Green dark green	13806Z-50----SCM	TBD	0.45 µm
Gray* white	130H6Z-50----SCM	14-555-629	0.45 µm High Flow
Gray* white	13006Z-47----SCM	14-555-628	0.45 µm
Gray* white	13006Z-50----SCM	TBD	0.45 µm
Gray* white	13005Z-47----SCM	TBD	0.65 µm
Gray* white	13005Z-50----SCM	TBD	0.65 µm
Gray* white	13004Z-47----SCM	TBD	0.8 µm
Gray* white	13004Z-50----SCM	14-555-619	0.8 µm

* Gray membranes after wetting black

Microsart® e.motion Membrane Filters are also available together with Nutrient Pads (page 25).

Cellulose Nitrate (Cellulose Ester) Membrane Filters, Gridded, Individually, Sterile Packaged

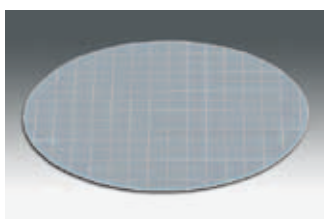
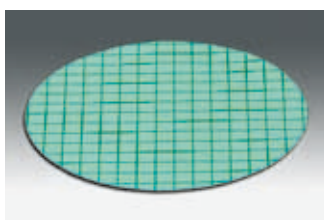
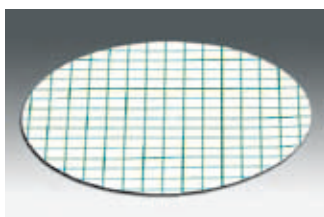
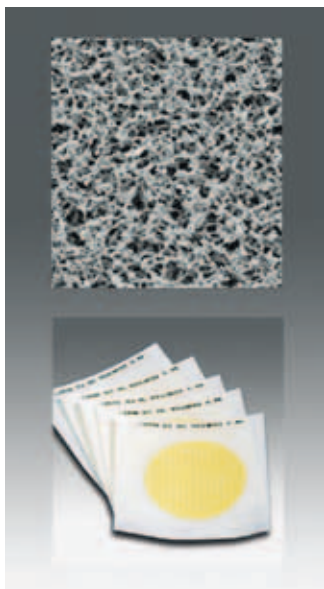

Applications

Membrane filters for colony counting, particle testing and microscopy

Some of the advantages you will benefit from when using this type of membrane filter:

- Outstanding recovery rates for microorganisms
- 0.45 µm are acc. to ISO 7704
- High Flow membranes available
- Three different colors available
- Certified quality
- Gamma irradiated, 25kGray

Specifications

Design	47 or 50 mm in diameter, white, grey or green and gridded
Growth Promotion Test acc. to ISO 7704	<ul style="list-style-type: none"> - No enhancement or inhibition by the grid lines - No enhancement or inhibition due to chemical extractables - No enhancement or inhibition by the sterilization process
Sterility test	Sterile
Thermal resistance	130°C max.
Thickness acc. to DIN 53105	115–145 µm
Chemical compatibility	Aqueous solutions (pH 4–8), hydrocarbons and several other organic solvents. Detailed information in section "Chemical Compatibility" under Cellulose Nitrate type 113 (page 68).

Typical performance rates for various pore sizes

Pore size		0.2 µm*	0.45 µm**	0.45 µm High Flow**	0.65 µm
Flow rate for water per cm ² at 1 bar acc. to DIN 58355	in ml/min	20	70	100	130
Coliform retention	in %	100	100	100	n. a.
Recovery rate lot-released acc. to ISO 7704	in %	≥ 90	≥ 90	≥ 90	≥ 90

*) Pore size determined by quantitative retention of *Brevundimonas diminuta* in accordance with the ASTM Document F 838-83 (1993) Standard test method for determining bacterial retention of membrane filters utilized for liquid filtration.

**) Pore size determined by quantitative retention of *Serratia marcescens* in accordance with the Standard Methods of Water and Waste Water

White membrane with black grid, for detection of bacteria with dyed media, particle count & microscopy, type 114, individually, sterile packaged

Pore size	Sartorius Stedim Order No.	Fisher Scientific Order No.	Diameter	Pack size
0.2 µm	11407--47----ACN	14-555-608	47 mm	100
	11407--47----ACR	14-555-609	47 mm	1,000
	11407--50----ACN	TBD	50 mm	100
	11407--50----ACR	TBD	50 mm	1,000
0.45 µm	11406--47----ACN	14-555-597	47 mm	100
	11406--47----ACR	14-555-598	47 mm	1,000
	11406--50----ACN	14-555-601	50 mm	100
	11406--50----ACR	TBD	50 mm	1,000
0.45 µm High Flow*	114H6--47----ACN	14-555-611	47 mm	100
	114H6--47----ACR	14-555-612	47 mm	1,000
	114H6--50----ACN	TBD	50 mm	100
	114H6--50----ACR	TBD	50 mm	1,000
0.65 µm	11405--47----ACN	14-5555-93	47 mm	100
	11405--50----ACN	TBD	50 mm	100
0.8 µm	11404--47----ACN	14-555-588	47 mm	100
	11404--47----ACR	14-555-589	47 mm	1,000
	11404--50----ACN	14-555-590	50 mm	100
1.2 µm	11403--47----ACN	14-555-584	47 mm	100
	11403--47----ACR	TBD	47 mm	1,000
	11403--50----ACN	14-555-585	50 mm	100
	11403--50----ACR	TBD	50 mm	1,000

White membrane with green grid, for detection of bacteria with dyed media, particle count and microscopy, type 139, individually, sterile packaged

0.45 µm	13906--47----ACN	14-555-654	47 mm	100
	13906--47----ACR	TBD	47 mm	1,000
	13906--50----ACN	14-555-655	50 mm	100
	13906--50----ACR	TBD	50 mm	1,000
0.45 µm High Flow*	139H6--47----ACN	14-555-657	47 mm	100
	139H6--47----ACR	TBD	47 mm	1,000
	139H6--50----ACN	TBD	50 mm	100
0.65 µm	13905--47----ACN	14-555-652	47 mm	100
1.2 µm	13903--47----ACN	14-555-651	47 mm	100

Green membrane with dark-green grid, providing optimal contrast to light-colored or transparent bacteria colonies, type 138, individually, sterile packaged

0.45 µm	13806--47----ACN	14-555-646	47 mm	100
	13806--47----ACR	14-555-647	47 mm	1,000
	13806--50----ACN	14-555-649	50 mm	100
	13806--50----ACR	TBD	50 mm	1,000

Gray membrane (after wetting, black) with white grid, for detection of yeasts and molds, particle count and microscopy, type 130, individually, sterile packaged

0.45 µm	13006--47----ACN	14-555-624	47 mm	100
	13006--47----ACR	14-555-625	47 mm	1,000
	13006--50----ACN	14-555-626	50 mm	100
	13006--50----ACR	TBD	50 mm	1,000
0.65 µm	13005--47----ACN	14-555-621	47 mm	100
	13005--50----ACN	TBD	50 mm	100
	13005--50----ACR	TBD	50 mm	1,000
0.8 µm	13004--47----ACN	14-555-616	47 mm	100
	13004--47----ACR	TBD	47 mm	1,000
	13004--50----ACN	14-555-617	50 mm	100

Cellulose Nitrate (Cellulose Ester) Membrane Filters, Gridded, Non-Sterile Packaged

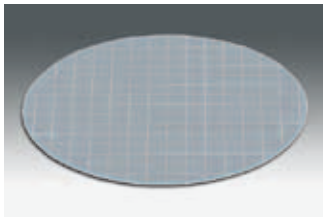
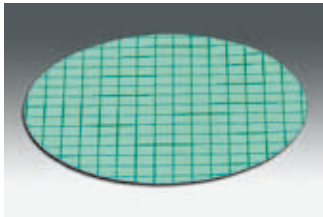
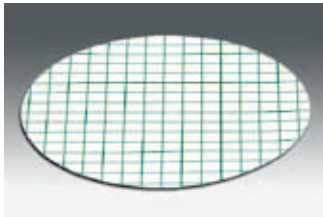
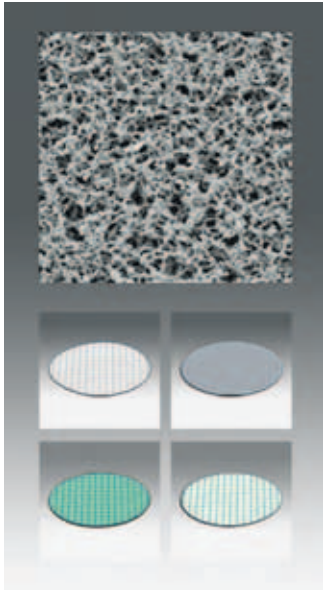

Applications

Membrane filters for colony counting, particle testing and microscopy

Some of the advantages you will benefit from when using this type of membrane filter:

- Outstanding recovery rates for microorganisms
- 0.45 µm are acc. to ISO 7704
- Three different colors available

Specifications

Design	25, 47 or 50 mm in diameter, white, grey or green and gridded
Growth Promotion Test acc. to ISO 7704	- No enhancement or inhibition by the grid lines - No enhancement or inhibition due to chemical extractables
Thermal resistance	130°C max.
Thickness acc. to DIN 53105	115–145 µm
Chemical compatibility	Aqueous solutions (pH 4–8), hydrocarbons and several other organic solvents. Detailed information in section "Chemical Compatibility" under Cellulose Nitrate type 113 (page 68).

Typical performance rates for various pore sizes

Pore size		0.2 µm*	0.45 µm**	0.65 µm
Flow rate for water per cm ² at 1 bar acc. to DIN 58355	in ml/min	20	70	130
Coliform retention	in %	100	100	n. a.
Recovery rate lot-released acc. to ISO 7704	in %	≥ 90	≥ 90	≥ 90

*) Pore size determined by quantitative retention of *Brevundimonas diminuta* in accordance with the ASTM Document F 838-83 (1993) Standard test method for determining bacterial retention of membrane filters utilized for liquid filtration.

**) Pore size determined by quantitative retention of *Serratia marcescens* in accordance with the Standard Methods of Water and Waste Water

White membrane with black grid, for detection of bacteria with dyed media, particle count & microscopy, type 114, non-sterile

Pore size	Sartorius Stedim Order No.	Fisher Scientific Order No.	Diameter	Pack size
0.2 µm	11407--25-----N	14-555-606	25 mm	100
	11407--47-----N	14-555-607	47 mm	100
	11407--47-----R	TBD	47 mm	1,000
	11407--50-----N	TBD	50 mm	100
0.45 µm	11406--25-----N	14-555-594	25 mm	100
	11406--47-----N	14-555-595	47 mm	100
	11406--47-----R	14-555-596	47 mm	1,000
	11406--50-----N	14-555-600	50 mm	100
	11406--50-----R	14-555-602	50 mm	1,000
0.65 µm	11405--47-----N	14-555-592	47 mm	100
0.8 µm	11404--25-----N	14-555-586	25 mm	100
	11404--47-----N	14-555-587	47 mm	100
	11404--50-----N	TBD	50 mm	100
1.2 µm	11403--25-----N	14-555-582	25 mm	100
	11403--47-----N	14-555-583	47 mm	100
	11403--50-----N	TBD	50 mm	100

White membrane with green grid, for detection of bacteria with dyed media, particle count and microscopy, type 139, non-sterile

0.45 µm	13906--47-----N	14-555-653	47 mm	100
	13906--47-----R	TBD	47 mm	1,000
	13906--50-----N	TBD	50 mm	100
	13906--50-----R	TBD	50 mm	1,000

Green membrane with dark-green grid, providing optimal contrast to light-colored or transparent bacteria colonies, type 138, non-sterile

0.45 µm	13806--47-----N	14-555-645	47 mm	100
	13806--47-----R	TBD	47 mm	1,000
	13806--50-----N	TBD	50 mm	100
	13806--50-----R	TBD	50 mm	1,000

Gray membrane (after wetting, black) with white grid, for detection of yeasts and molds, particle count and microscopy, type 130, non-sterile

0.45 µm	13006--25-----N	14-555-622	25 mm	100
	13006--47-----N	14-555-623	47 mm	100
	13006--47-----R	TBD	47 mm	1,000
	13006--50-----N	TBD	50 mm	100
0.65 µm	13005--47-----N	14-555-620	47 mm	100
	13005--50-----N	TBD	50 mm	100
0.8 µm	13004--47-----N	14-555-615	47 mm	100
	13004--50-----N	TBD	50 mm	100

Cellulose Nitrate (Cellulose Ester) and Cellulose Acetate Membrane Filters, White, Individually, Sterile Packaged

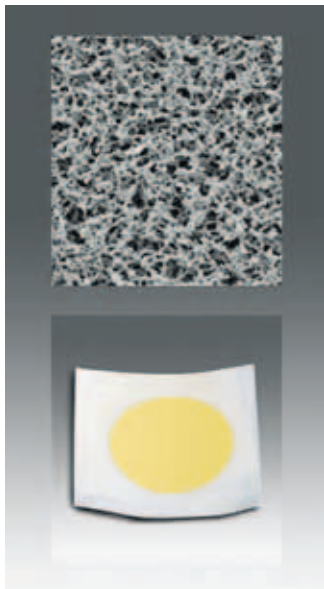

Sterile, individually packed filters have long become standard for routine microbiological quality control because of the user benefits they offer. They are pre-sterilized and ready-to-use and save preparatory time. As they are individually packed, they avoid the possibility of contaminating remaining filters in opened packs and conform with GLP, having filter identification and lot number printed on each individual envelope.

Materials

The membranes are made of even cellulose nitrate (cellulose ester), a material which assures effective retention with high flow rates and optimum colony growth or cellulose acetate, a material which combines high flow rates and thermal stability with very low adsorption characteristics.

Additional applications

11301, a white CN membrane filter with a pore size of 8 μm is used as a prefilter in a special prefilter attachment (Sartorius Stedim Order No. 16807 | Fisher Scientific Order No. 14-555-907) for bacteriological analyses. It retains the coarse suspended particles, whereas it allows microorganisms to pass through. These microbes are trapped on the surface of the underlying bacteria-retentive membrane filter (e. g. 0.45 μm).

11107, a white CA membrane filter with a pore size of 0.2 μm is the filter of choice for sterile filtration, such as nutrient media, buffer and sera. This membrane is validated by the Bacteria Challenge Test.

Applications

Membrane filters for colony counting, sterility testing, particle testing and microscopy

Some of the advantages you will benefit from when using this type of membrane filter:

- Outstanding recovery rates for microorganisms
- Defined particle retention
- 0.45 μm are acc. to ISO 7704
- 0.2 μm are validated by BCT
- Certified quality
- Gamma-irradiated, 25kGray

Specifications

Design	25, 47 or 50 mm in diameter, white
Growth Promotion Test acc. to ISO 7704	<ul style="list-style-type: none"> - No enhancement or inhibition by the sterilization process - No enhancement or inhibition due to chemical extractables
Sterility test	Sterile
Thermal resistance	CN: 130°C max. CA: 180°C max.
Thickness acc. to DIN 53105	CN: 115–145 µm CA: 120 µm (average value)
Chemical compatibility	Aqueous solutions (pH 4–8), hydrocarbons and several other organic solvents. Detailed information in section "Chemical Compatibility" under Cellulose Nitrate type 113 and Cellulose Acetate type 111 (page 68).

Cellulose nitrate membrane filters, white, for colony counting, sterility testing, particle count & microscopy, type 113, individually, sterile packaged

Pore size	Sartorius Stedim Order No.	Fisher Scientific Order No.	Diameter	Pack size
0.45 µm	11306--25----ACN	TBD	25 mm	100
	11306--47----ACN	14-555-577	47 mm	100
	11306--50----ACN	14-555-578	50 mm	100
0.65 µm	11305--47----ACN	14-555-576	47 mm	100
	11305--50----ACN	TBD	50 mm	100
0.8 µm	11304--47----ACN	14-555-575	47 mm	100
	11304--50----ACN	TBD	50 mm	100
1.2 µm	11303--47----ACN	14-555-574	47 mm	100
	11303--50----ACN	TBD	50 mm	100
3 µm	11302--47----ACN	14-555-571	47 mm	100
	11302--50----ACN	TBD	50 mm	100
8 µm	11301--47----ACN	14-555-568	47 mm	100
	11301--50----ACN	14-555-569	50 mm	100

Cellulose acetate* membrane filters, white, for colony counting, sterility testing, particle count & microscopy, type 111, individually, sterile packaged

0.2 µm	11107--47----ACN	14-555-565	47 mm	100
	11107--50----ACN	14-555-566	50 mm	100
0.45 µm	11106--47----ACN	14-555-562	47 mm	100
	11106--50----ACN	14-555-563	50 mm	100

* If cellulose nitrate is not compatible

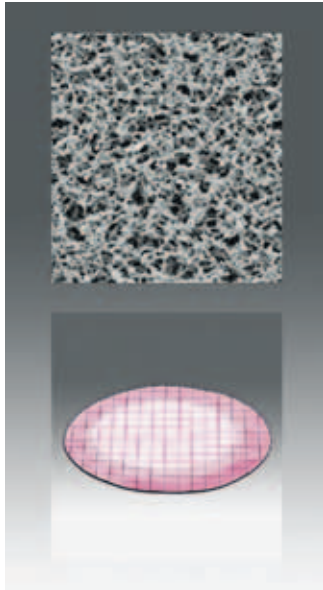

Hydrophobic Edged Cellulose Nitrate (Cellulose Ester), Cellulose Acetate and Regenerated Cellulose Membrane Filters, Individually, Sterile Packaged & Non-Sterile

Hydrophobic edge membranes are used mainly for colony counting and sterility testing of solutions containing substances with antibiotic characteristics. The hydrophobic edge avoids the penetration of any growth-inhibitory substance into the membrane clamp zone wherefrom it could not be rinsed out and the substance could inhibit microbial growth during incubation.

Materials

The membranes are available in three different materials:

- Cellulose nitrate (cellulose ester), a material which assures effective retention with high flow rates and optimum colony growth
- Cellulose acetate, a material which combines high flow rates and thermal stability with very low adsorption characteristics
- Regenerated cellulose, a material which combines excellent chemical resistance and thermal stability with very low adsorption characteristics.

Applications

Membrane filters for colony counting and sterility testing

Some of the advantages you will benefit from when using this type of membrane filter:

- Outstanding retention rates for microorganisms
- 0.45 μm are acc. to ISO 7704
- 0.2 μm are validated by BCT
- Certified quality

Specifications

Design	25, 47 or 50 mm in diameter, white or white with black grid
Growth Promotion Test acc. to ISO 7704	<ul style="list-style-type: none"> - No enhancement or inhibition by the grid lines - No enhancement or inhibition due to chemical extractables - No enhancement or inhibition by the sterilization process
Sterility test	Sterile
Thermal resistance	CN: 130°C max. CA and RC: 180°C max.
Thickness acc. to DIN 53105	CN: 115–145 μm CA: 120 μm (average value) RC: 160–200 μm
Chemical compatibility	Aqueous solutions (pH 4–8), hydrocarbons and several other organic solvents, RC is resistant to almost all solvents and is compatible in a pH-range of 3–12. Detailed information in section "Chemical Compatibility" under Cellulose Nitrate type 113, page 68, Cellulose Acetate type 111 and Regenerated Cellulose type 184.

**Cellulose nitrate membrane filters, white with black grid,
3 mm hydrophobic edge, for colony counting & sterility testing, type 131,
individually, sterile packaged**

Pore size	Sartorius Stedim Order No.	Fisher Scientific Order No.	Diameter	Pack size
0.2 µm	13107--47----ACN	14-555-637	47 mm	100
	13107--50----ACN	TBD	50 mm	100
0.45 µm	13106--47----ACN	14-555-633	47 mm	100
	13106--50----ACN	14-555-635	50 mm	100

**Cellulose nitrate membrane filters, white with black grid,
6 mm hydrophobic edge, for colony counting & sterility testing, type 131,
individually, sterile packaged**

0.45 µm	13106--47----HEN	TBD	47 mm	100
---------	------------------	-----	-------	-----

**Cellulose nitrate membrane filters, white with black grid, 3 mm hydrophobic
edge, for colony counting & sterility testing, type 131, non-sterile**

0.2 µm	13107--25-----N	14-555-636	25 mm	100
	13107--47-----N	TBD	47 mm	100
	13107--50-----N	TBD	50 mm	100
0.45 µm	13106--25-----N	14-555-631	25 mm	100
	13106--47-----N	14-555-632	47 mm	100
	13106--50-----N	TBD	50 mm	100
8 µm	13101--47-----N	14-555-630	47 mm	100
	13101--50-----N	TBD	50 mm	100

**Cellulose nitrate membrane filters, white, 3 mm hydrophobic edge,
for colony counting & sterility testing, type 131, non-sterile**

8 µm	13101--50----AHN	TBD	50 mm	100
------	------------------	-----	-------	-----

**Cellulose nitrate membrane filters, white with black grid, 6 mm hydrophobic
edge, for colony counting & sterility testing, type 131, non-sterile**

0.2 µm	13107--47----HCN	TBD	47 mm	100
0.45 µm	13106--47----HCN	TBD	47 mm	100

**Cellulose acetate* membrane filters, white with black grid,
3 mm hydrophobic edge, for colony counting & sterility testing, type 135,
individually, sterile packaged**

0.2 µm	13507--47----ACN	14-555-644	47 mm	100
0.45 µm	13506--47----ACN	14-555-639	47 mm	100
	13506--50----ACN	TBD	50 mm	100

**Cellulose acetate* membrane filters, white with black grid,
3 mm hydrophobic edge, for colony counting & sterility testing, type 135,
sterile, packaged of 10 discs per sleeve**

0.45 µm	13506--47----ALS	TBD	47 mm	100
---------	------------------	-----	-------	-----

**Cellulose acetate* membrane filters, white with black grid, 3 mm hydrophobic
edge, for colony counting & sterility testing, type 135, non-sterile**

0.2 µm	13507--47-----N	14-555-643	47 mm	100
0.45 µm	13506--47-----N	14-555-638	47 mm	100

**Cellulose acetate* membrane filters, white with black grid, 6 mm hydrophobic
edge, for colony counting & sterility testing, type 135, non-sterile**

0.45 µm	13506--47----HCN	TBD	47 mm	100
---------	------------------	-----	-------	-----

**Regenerated cellulose* membrane filters, white, hydrophobic edged,
for colony counting & sterility testing, type 184, 100 membranes per box,
individually, sterile packaged**

0.45 µm	18406--47----ACN	TBD	47 mm	3 mm hydropho. edge
	18406--47----HDN	TBD	47 mm	4 mm hydropho. edge

* If cellulose nitrate is not compatible

Nutrient Pad Sets – Dehydrated Media Pads in Petri Dishes, with Matching Membrane Filters for Economical, Time-saving Microbiological Quality Control



Sartorius Stedim Biotech Nutrient Pad Sets have been used successfully in the membrane filter method for 30 years. Practical and easy to handle, they reduce labor and simplify many microbiological testing procedures.

Nutrient pads are sterile, dehydrated culture media. Once they are moistened with 3.0–3.5 ml of sterile and demineralized (or distilled) water they are ready to use immediately.



Ready-to-use up to 24 months

The standard NPS box contains 100 sterile nutrient pads, each of which is individually inserted in a petri dish and sterilized. Ten each of these petri dishes are sealed in an aluminum bag. This special packaging in bags protects the sensitive formula constituents of the nutrient pads during transport and storage from fluctuations in humidity and temperature. As a result, it guarantees the high quality of our NPS throughout their entire shelf life up to 24 months. This makes the Sartorius Stedim Biotech Nutrient Pads Sets unique: No other ready-to-use culture media around the globe assures such consistently high quality and reproducible results up to 24 months.

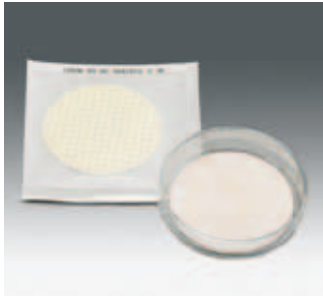

Compliance with International Standards

Currently, Sartorius Stedim Biotech offers more than 30 different Nutrient Pad Set types to meet the diverse objectives of microbiological analysis. Aside from the European drinking water directive, they comply with other international regulations and recommendations: international pharmacopoeias, DIN and ISO standards, the American Standards for Water and Foods, mineral water regulations, brewery guidelines, such as MEBAC or EBC, and recommendations of the food industry, such as LMBG, NCA and ICUMSA, etc.

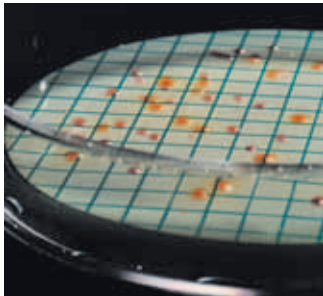

Inclusive membranes

All Nutrient Pad Set types are supplied with the appropriate membrane filters, which are also pre-sterilized and individually packaged. Microsart® e.motion Membrane Filters are specially designed for the Microsart® e.motion Dispenser and can be conveniently inserted. The membrane filters then are automatically removed from their sterile package – either in a touch-free mode via an optical sensor or at the touch of a button. All membrane filters tailored to meet the special requirements of microbial detection are available with 47 mm or 50 mm diameters.

Benefits for the user

Economy

No time-consuming and labor-intensive preparation of the nutrient media (sterilization, cleaning, etc.).

Easy handling

Nutrient Pad Sets can also be used in laboratories without comprehensive microbiological equipment.

Consistently quality

During the production, each nutrient pad set batch is compared with the corresponding agar medium, in order to guarantee consistently quality and reproducible results.

Trouble-free storage

Nutrient Pad Sets can be stored at room temperature in a warehouse, up to 24 months.

Order numbers for nutrient pad sets in petri dishes

Nutrient Pad Sets for total colony counting, individually, sterile packaged in petri dishes, 100 per box, with 100 individually, sterile packaged 47 mm membrane filters (order no. -RDN = Microsart® e.motion Membranes)

Determination of	NPS type (Filter type) ¹	Sartorius Stedim Order No. ²	Fisher Scientific Order No.
Total count	Caso (1)	14063--47-----N	14-555-690
Total count	R2A (1)	14084--47----RDN	TBD
Total count	R2A (1)	14084--47-----N	14-555-721
Total count	Standard TTC (1)	14055--47----RDN	14-555-676
Total count	Standard TTC (1)	14055--47-----N	14-555-674
Total count	Standard TTC I mod. (1)	14085--47-----N	TBD
Total count	Standard (1)	14064--47-----N	14-555-691
Total count	TGE Tryptone Glucose Extract (1)	14076--47----RDN	TBD
Total count	TGE Tryptone Glucose Extract (1)	14076--47-----N	14-555-711
Total count	Yeast Extract (1)	14090--47-----N	TBD

Nutrient Pad Sets for E. coli, coliforms and enterobacteria, individually, sterile packaged in petri dishes, 100 per box, with 100 individually, sterile packaged 47 mm membrane filters (order no. -RDN = Microsart® e.motion Membranes)

E. coli and coliforms	Chromocult (7)	14087--47----RDN	TBD
E. coli and coliforms	Chromocult (7)	14087--47-----N	14-555-725
E. coli	ECD (2)	14082--47-----N	14-555-718
E. coli and coliforms	Endo (9)	14053--47----RDN	14-555-672
E. coli and coliforms	Endo (9)	14053--47-----N	14-555-670
Enterobacteria, E. coli	MacConkey (2)	14097--47-----N	14-555-729
E. coli and coliforms	m FC (2)	14068--47-----N	14-555-700
E. coli and coliforms	m FC in closed petri dishes (2)	14068--50----PDN	TBD
E. coli and coliforms	Teepol Lauryl Sulphate (2)	14067--47----RDN	TBD
E. coli and coliforms	Teepol Lauryl Sulphate (2)	14067--47-----N	14-555-698
E. coli and coliforms	Tergitol TTC (2)	14056--47----RDN	TBD
E. coli and coliforms	Tergitol TTC (2)	14056--47-----N	14-555-678

Nutrient Pad Sets for other faecal bacteria, individually, sterile packaged in petri dishes, 100 per box, with 100 individually, sterile packaged 47 mm membrane filters (order no. -RDN = Microsart® e.motion Membranes)

Enterococci	Azide KF Strep (1)	14051--47----RDN	TBD
Enterococci	Azide KF Strep (1)	14051--47-----N	14-555-669
Salmonellae	Bismuth Sulphite (1)	14057--47-----N	14-555-679

Nutrient Pad Sets for non-faecal, pathogenic bacteria, individually, sterile packaged in petri dishes, 100 per box, with 100 individually, sterile packaged 47 mm membrane filters (order no. -RDN = Microsart® e.motion Membranes)

Pseudomonas aeruginosa	Cetrimide (2)	14075--47----RDN	TBD
Pseudomonas aeruginosa	Cetrimide (2)	14075--47-----N	14-555-709
Staphylococci, Staph. aureus	Chapman (2)	14074--47-----N	14-555-708

Nutrient Pad Sets for yeasts and molds, individually, sterile packaged in petri dishes, 100 per box, with 100 individually, sterile packaged 47 mm membrane filters (order no. -RDN = Microsart® e.motion Membranes)

Determination of	NPS type (Filter type) ¹	Sartorius Stedim Order No. ²	Fisher Scientific Order No.
Wild yeasts	Lysine (3)	14061--47-----N	14-555-686
Yeasts and molds	Malt Extract (8)	14086--47----CCN	14-555-724
Yeasts and molds	Malt Extract (6)	14086--47-----N	14-555-723
Yeasts and molds	Sabouraud (10)	14069--47-----N	14-555-703
Yeasts and molds	Schaufus Pottinger m green yeast and mold (4)	14070--47-----N	14-555-705
Yeasts and molds	Schaufus Pottinger m green yeast and mold (5)	14072--47-----N	14-555-707
Yeasts and molds	Schaufus Pottinger m green yeast and mold (6)	14080--47----RDN	14-555-716
Yeasts and molds	Schaufus Pottinger m green yeast and mold (6)	14080--47-----N	14-555-715
Yeasts and molds	Schaufus Pottinger m green yeast and mold (3)	14083--47-----N	14-555-719
Yeasts and molds	Schaufus Pottinger m green yeast and mold (8)	14091--47----RDN	TBD
Yeasts and molds	Schaufus Pottinger m green yeast and mold (8)	14091--47-----N	TBD
Yeasts and molds and bacteria	Wallerstein Nutrient WL Nutrient (2)	14089--47-----N	14-555-726
Yeasts and molds	Wort (3)	14058--47----RDN	14-555-682
Yeasts and molds	Wort (3)	14058--47-----N	14-555-681
Yeasts and molds	Wort (8)	14092--47-----N	TBD

Nutrient Pad Sets for product-spoiling microorganisms, individually, sterile packaged in petri dishes, 100 per box, with 100 individually, sterile packaged 47 mm membrane filters (order no. -RDN = Microsart® e.motion Membranes)

Thermophilic spore formers and mesophilic bacteria	Glucose Tryptone (2)	14066--47-----N	14-555-696
Leuconostoc oenos and other wine-spoiling organ.	Jus de Tomate Tomato Juice (1)	14079--47-----N	14-555-713
Lactobacilli and other soft drink-spoiling microorganisms	MRS (1)	14077--47-----N	TBD
Acid-tolerant microorganisms	Orange Serum pH 5.5 (1)	14062--47----RDN	TBD
Acid-tolerant microorganisms	Orange Serum pH 5.5 (1)	14062--47-----N	14-555-688
Acid-tolerant microorganisms	Orange Serum pH 3.2 (6)	14096--47----RDN	TBD
Acid-tolerant microorganisms	Orange Serum pH 3.2 (6)	14096--47-----N	14-555-728
Lactobacilli and Pediococci and other beer-spoiling microorganisms	VLB-S7-S (2)	14059--47-----N	14-555-684
Mesophilic slime-forming bacteria esp. Leu. mesenteroides	Weman (1)	14065--47-----N	14-555-694

Nutrient Pad Sets starter kit, individually, sterile packaged in petri dishes, 100 per box, with 100 individually, sterile packaged 47 mm membrane filters

Determination of	NPS type (Filter type) ¹	Sartorius Stedim Order No. ²	Fisher Scientific Order No.
E. coli and coliforms, total count, yeasts and molds	Mixed types: Endo, Standard, Wort (1, 2, 3)	14095--47-----N	14-555-727

Special brochure available on request f.o.c. Order no. SM-4017-e.

1) The membrane filters are selected for optimum growth, together with the corresponding nutrient media. The supplied membrane filter type is listed within brackets:

- (1) = Green with dark-green grid, 0.45 µm pore size
- (2) = White with green grid, 0.45 µm pore size
- (3) = Gray (after wetting black) with white grid, 0.65 µm pore size
- (4) = White with green grid, 0.65 µm pore size
- (5) = White with green grid, 1.2 µm pore size
- (6) = Gray (after wetting black) with white grid, 0.8 µm pore size
- (7) = White with black grid, 0.45 µm pore size
- (8) = Gray (after wetting black) with white grid, 0.45 µm pore size
- (9) = White with green grid, 0.45 µm pore size, High Flow (ideal for E.coli)
- (10) = Gray (after wetting black) with white grid, 0.45 µm pore size, High Flow

2) Diameter of the membrane filter, 47 mm. Order number for Nutrient Pad Set with 50 mm membrane filter as above, but --47-----N replaced by --50-----N.

Most of the NPS types are also available with Microsart® e.motion Membrane Filters: Order number as above, but ---N replaced by -RDN.

Other NPS types and NPS with Microsart® e.motion Membrane Filters on request.



Nutrient Pad Set poster

The photo shows a poster, original size 70 cm x 50 cm, with growth patterns and typical applications for the Nutrient Pad Sets, described on the previous page. On request, you can obtain this poster free of charge. Order no. SM-0001-e.

Culture Media in Bottles and Tubes Absorbent Pads and Petri Dishes



Agar Media

The traditional culture media for microorganisms is agar media. This can be used for the membrane filtration method or for direct incubation. There are two different forms available: Agar media in tubes are for pouring agar plates. The content of one tube is sufficient for two 90 mm or three 60 mm petri dishes. Agar media in bottles are the cost-effective alternative for casting plates.



Liquid broth media

Liquid culture media broth for direct incubation or for wetting an absorbent pad before a membrane filter is placed on it. They are available in tubes and in bottles.



Absorbent pads

Sartorius Stedim Biotech 1.4 mm thick absorbent pads are wetted with the appropriate liquid culture medium before a membrane filter is placed on them. They come pre-sterilized in plastic magazines, which fit onto the Sartorius Stedim Biotech manual dispensing device. The absorbent pads are available in two diameters:

- 47 mm with approx. 3 ml absorption capacity and
- 50 mm with approx. 3.5 ml absorption capacity.

Agar Media in 250 ml bottles, 4 bottles per box

Determination of	Agar type	Sartorius Stedim Order No.	Fisher Scientific Order No.
Total count	Nutrient	14144-----A	TBD
Yeasts and molds	Wort	14157-----A	TBD
Wild yeasts	Lysine	14143-----A	14-555-740
Lactobacilli and Pediococci and other beer-spoiling organisms	VLB-S7-S	14148-----A	TBD

Agar Media in 20 ml tubes, 50 tubes per box

Determination of	Agar type	Sartorius Stedim Order No.	Fisher Scientific Order No.
Total count	Nutrient	14137-----K	TBD
Total count	Standard	14131-----K	14-555-738
Yeasts and molds	Wort	14138-----K	14-555-739
Acid-tolerant microorganisms	Orange serum	14130-----K	TBD
Leuconostoc oenos and other wine-spoiling organ.	Jus de tomate (tomato juice)	14140-----K	TBD

Lactose broth media, bottled concentrate, for drinking water analysis

Concentration factor	Packaging	Sartorius Stedim Order No.	Fisher Scientific Order No.
Two times concentrated	4 bottles à 100 ml	14155-----A	TBD

Broth media in 20 ml tubes, 50 tubes per box

Determination of	Broth type	Sartorius Stedim Order No.	Fisher Scientific Order No.
Lactobacilli and Pediococci and other beer-spoiling organisms	VLB-S7-S	14127-----K	TBD

Absorbent Pads, 47 mm, sterile packaged in 10 magazines, each with 100 pads

Description	Packaging	Sartorius Stedim Order No.	Fisher Scientific Order No.
Absorbent Pads, 10×100 pads	1,000 per box, incl. one dispenser	15410--47----ALR	14-555-732
Absorbent Pad Set, 10×100 pads plus 1,000 membrane filters (0.45 µm, white green)	1,000 per box, incl. two dispensers	13906--47----APR	TBD

Absorbent Pads, 47 mm, sterile packaged of 10 discs per sleeve

Description	Packaging	Sartorius Stedim Order No.	Fisher Scientific Order No.
Absorbent Pad Set, 10×10 pads in sleeves plus 100 membrane filters (0.2 µm, white black)	100 per box	13707--47----ALN	TBD
Absorbent Pad Set, 10×10 pads in sleeves plus 100 membrane filters (0.45 µm, white black)	100 per box	13706--47----ALN	TBD

Absorbent Pads, 50 mm, sterile-packaged in 10 magazines, each with 100 pads

Description	Packaging	Sartorius Stedim Order No.	Fisher Scientific Order No.
Absorbent Pads, 10×100 pads	1,000 per box, incl. one dispenser	15410--50----ALR	14-555-733

Absorbent Pads, 50 mm, sterile-packaged in petri dishes

Description	Packaging	Sartorius Stedim Order No.	Fisher Scientific Order No.
Absorbent Pad Set, 100 pads in petri dishes, sterile packaged	100 per box	15400--50-----N	14-555-730
Absorbent Pad Set, 100 pads in petri dishes plus 100 membrane filters (0.45 µm, green dark green)	100 per box	15400--50----FRN	TBD

Disposable petri dishes, auto-sterile, 100 per box

Diameter	Sartorius Stedim Order No.	Fisher Scientific Order No.
60 mm	14311--60-----N	14-555-734
90 mm	14311--90-----N	14-555-735

Biosart® 100 Monitors



The membrane filtration method is the suitable technique for microbiological analysis of pharmaceuticals, water, cosmetics, foods and beverages. The use of ready-to-use disposable units is optimal for these applications.

Biosart® 100 Monitors

Biosart® 100 Monitors have been specifically designed for the detection and enumeration of microorganisms in pharmaceuticals, cosmetics, food, beverages, water and other liquids. These sterile disposables with an incorporated membrane filter and cellulose pad are ready to use. After filtration, just remove the 100 ml funnel to convert the Monitor into a petri dish eliminating the need for membrane manipulation. Culture media for wetting the pad are available in individually sterilized, convenient plastic ampoules. Biosart® 100 Monitors are ready-to-use filter units designed to be placed onto the bases of a vacuum manifold, eliminating the cleaning and sterilization required of reusable funnels.

Compliance with International Standards

The membrane filter method is worldwide accepted and the preferred method of choice for the analysis of microbial contamination in liquid samples. Biosart® 100 Monitors and Media are in compliance with the membrane filtration procedures referenced in the:

- European drinking water directive (Council Directive 98/83/EC on the quality of water)
- Standard Methods for the Examination of Water and Waste Water, 20th edition
- U.S. Environmental Protection Agency, 600/8-78-017.

- International Standard's microbiological methods, such as ISO 7704, ISO 9308-1, DIN EN ISO 16266, ISO 8199
- WHO Guidelines for Drinking Water Quality, 1997
- International Pharmacopoeia, such as the current editions of the USP and EP

High Flow membranes

Biosart® 100 Monitors are also available with the new 0.45 µm High Flow membranes. The special pore structure allows shorter filtration times due to 30% higher flow rates. Especially E. coli shows best growth promotion on High Flow Membranes.

Applications

Colony counting, particle testing and microscopy

Some of the advantages you will benefit from when using Biosart® 100 Monitors:

Superior performance

- High flow rate
- High total throughput

Safe & reliable

- Sterile or individually, sterile packaged
- Consistently recovery
- Membranes meet ISO 7704
- Membranes available in various colors
- Without any hydrophobic adhesive areas

Economical

- Ready to connect and easy to use
- Minimal amount of equipment needed

Specifications

Housing	Polystyrene
Membrane filter	Cellulose nitrate (cellulose ester): choice of white, green or grey, with grid; Regenerated cellulose: white; membranes removable for filing
Plug and adapter	Polyethylene
Pad	Cellulose
Capacity	100 ml, 10 ml graduations
Pore size	0.2 µm, 0.45 µm or 0.8 µm
Filter diameter	47 mm
Filtration area	14.5 cm ²
Max. operating pressure	Vacuum only
Outlet	6.5 × 1.5 mm
Lot certificates	Recovery rate, sterility and specifications

Biosart® 100 Monitors, 100 ml, 47 mm, individually packaged, sterile, 48 units

Pore size	Membrane filter* color grid color	Sartorius Stedim Order No.	Fisher Scientific Order No.
0.2 µm	CN white black	16401-47-07--ACK	14-555-747
0.45 µm	CN white black	16401-47-06--ACK	14-555-743
0.45 µm	CN green dark green	16402-47-06--ACK	14-555-752
0.45 µm	CN gray white**	16403-47-06--ACK	14-555-756

Biosart® 100 Monitors, 100 ml, 47 mm, packaged on trays, sterile, 48 units

0.2 µm	CN white black	16401-47-07----K	14-555-746
0.45 µm High Flow	CN white black	16401-47-H6----K	14-555-748
0.45 µm	CN white black	16401-47-06----K	14-555-742
0.45 µm	CN green dark green	16402-47-06----K	14-555-751
0.45 µm	CN gray white**	16403-47-06----K	14-555-755
0.8 µm	CN gray white**	16403-47-04----K	14-555-753
0.45 µm	RC white	16404-47-06----K	14-555-760

Biosart® 100 Monitors, 100 ml, 47 mm, sterile, 48 units

0.45 µm High Flow	CN white black	16401-47-H6-V--K	14-555-749
0.45 µm	CN white black	16401-47-06-V--K	14-555-744
0.45 µm	CN gray white**	16403-47-06-V--K	14-555-757
0.8 µm	CN gray white**	16403-47-04-V--K	14-555-754

Biosart® 100 Monitors, 100 ml, 47 mm, sterile, 48 units, membrane fixed

available only in the U.S. and Canada

0.45 µm High Flow	CN white black	16401-47-H6-VWMK	14-555-750
0.45 µm	CN white black	16401-47-06-VWMK	14-555-745
0.45 µm High Flow	CN gray white**	16403-47-H6-VWMK	14-555-759
0.45 µm	CN gray white**	16403-47-06-VWMK	14-555-758

* CN = Cellulose Nitrate (Cellulose ester)

RC = Regenerated Cellulose

** Gray membranes after wetting black

Biosart® 100 Monitor Adapters and Membrane Lifter

Description	Adaptation	Sartorius Stedim Order No.	Fisher Scientific Order No.
Biosart® 100 Adapter, polypropylene and silicone	Biosart® 100 Monitor onto stainless steel frits e. g. Sartorius Stedim Order No. 16840 Fisher Scientific Order No. 14-555-798 (Combisart® single base, 50 mm) or onto Sartorius Stedim Order No. 16841 Fisher Scientific Order No. 14-555-799 (individual base)	16424	TBD
Biosart® 100 Adapter, silicone	equal 16424 TBD	16414	14-555-778
Biosart® 100 Adapter, polypropylene	Biosart® 100 Monitor onto 50 mm supports	16415	14-555-779
Biosart® 100 Adapter, polypropylene	Biosart® 100 Monitor onto 56 mm supports and vacuum pumps	16416	TBD
Biosart® 100 Membrane Lifter, ABS	for easy transfer of the membrane onto agar	16417	14-555-780

Biosart® 100 Nutrient Media



Each box of Biosart® 100 Nutrient Media contains 50 ampoules with sterile media, each with 2.5 ml and a lot certificate. If stored under proper conditions (+4°C), the culture media have a shelf life of 12 month (except for Endo, KF Strep, Lauryl Sulfate and Tergitol which have a 9-month shelf life). Biosart® 100 Nutrient Media comply with international regulations and recommendations: International pharmacopoeias, DIN and ISO standards, the American Standards for Water and Foods, mineral water regulations, guidelines of the food and beverage industries.

Within the scope of the quality assurance procedure and the stringent quality control standards every batch has passed Sartorius Stedim Biotech in-house tests of growth promotion, sterility, physical and technical parameters have been passed successfully. Biosart® 100 Nutrient Media are convenient in use and eliminating the handling of glass ampoules.

Application

Colony counting

Some of the advantages you will benefit from when using Biosart® 100 Media:

Safe & reliable

- Pre-sterilized media
- Certificate of Quality for every batch
- In compliance with international standards
- Consistently recovery

Economical

- Ready-to-use
- Long shelf life

Biosart® 100 Nutrient Media, 2.5 ml, individually, sterile-packaged in ampoules, 50 units

Determination of	Media type	Sartorius Stedim Order No.	Fisher Scientific Order No.
Total count	Caso (acc. USP)	16400-02----CA-K	14-555-763
Total count	R2A (acc. EP)	16400-02----RA-K	14-555-771
Total count	TGE Total Count	16400-02----TC-K	14-555-773
Total count	Total Count TTC	16400-02----TZ-K	14-555-774
E. coli and coliforms	m Endo	16400-02----EN-K	14-555-765
E. coli and coliforms	m FC	16400-02----MF-K	14-555-768
E. coli and coliforms	Lauryl Sulfate Teepol	16400-02----LS-K	TBD
E. coli and coliforms	Tergitol TTC	16400-02----TT-K	TBD
Enterococci	KF Strep Azide	16400-02----KF-K	14-555-767
Pseudomonas aeruginosa	Cetrimide	16400-02----CE-K	14-555-764
Yeasts and molds	Sabouraud (acc. USP)	16400-02----SB-K	14-555-772
Yeasts and molds	m Green yeast and mold Schaufus Pottinger	16400-02----MG-K	14-555-769
Yeasts and molds	m Green yeast and mold selective	16400-02----GS-K	14-555-766
Yeasts and molds	Wort	16400-02----WZ-K	14-555-777
Yeasts and molds and bacteria	WL Nutrient Wallerstein Nutrient	16400-02----WN-K	14-555-776
Bacteria in fermentation processes	WL Differential Wallerstein Differential	16400-02----WL-K	14-555-775
Acid-tolerant microorganisms	Orange Serum	16400-02----OS-K	14-555-770

Microsart® @filter 100 | Microsart® @filter 250

Sterile disposable filter units for advanced colony counting



The process of producing pharmaceuticals and bringing new drugs to the market is becoming an increasingly costly business. The pharmaceutical and biotech industries are driven by the need to optimize their work flows and increase efficiency without compromising their level of safety. Products and raw materials used in the pharmaceutical or biotech industry require control of microbial levels during processing and handling. Microorganisms in liquids are quantified by the membrane filtration method. Use of this membrane filtration method allows accurate quantification of bacteria, yeasts and molds when low counts in a high sample volume are anticipated. All components of the filtration system must comply with international guidelines, such as USP, EP or ISO standards.

Description

Microsart® @filter 100 and 250 filter units are a ready-to-use combination funnel, filter base and gridded membrane in one unit. The range of Microsart® @filter types has been tailored to meet individual needs: It is possible to choose between two volume sizes, 100 ml and 250 ml, different pore sizes and different filter colors for contrasting backgrounds during evaluation. The filter units exist as tray versions with lids or are stacked in bags for safe removal using the Microsart® Funnel Dispenser.

Despite the diversity of Microsart® @filters one thing is common: The optimal design.

- Click-Fit fastening allows for easy removal of funnels
- Leaking-free procedure due to innovative Click-Fit and bayonet closures
- Bayonet closure allows for easy mounting and removal of units
- Sterile Filter Base with recesses allows for simple membrane removal
- Innovative geometry of the funnel allows for effective rinsing after filtration (no sample residue is left in the funnel)

They have been specifically developed for the detection and enumeration of microorganisms in pharmaceuticals, biopharmaceuticals and cosmetics.

Microsart® @vance®

The Microsart® product family consists of all the most recent products from SSB for microbiological analysis, which are especially characterized by innovation and clever design. The Microsart® @filter unit kicks off the new product line Microsart® @vance®. @vance® stands for even more progress and intelligent design, enhanced safety and thus more reliable results. The products in the Microsart® @vance® line have been specially developed for analyses in the pharmaceutical and biotechnological industry. Following the trend of using single-use products, these products are delivered sterile, ready-to-use and can be disposed of in an environmentally friendly manner. Microsart® @filter not only saves time and labor costs but minimizes the risk of secondary contamination – that's advanced colony counting by Sartorius Stedim Biotech.

Microsart® Funnel Dispenser

The Funnel Dispenser for secure removal of single, sterile Microsart® @filter has proven itself in practice. Even after opening the bag, the remaining funnels are protected from secondary contamination. The Microsart® Funnel Dispenser is made of high-grade stainless steel, the dispenser opening is made of polypropylene and contains a silicone O-ring. All these materials guarantee reliable autoclaving.

Applications

Colony counting and microscopy

Some of the advantages you will benefit from when using Microsart® @filter units:

Safe and reliable

- **Sterile packaged**
Sterilization at the point of use is not required
- **Fully disposable base and funnel**
Preparation- and sterilization-free procedure reduces the risk of secondary contamination
- **Optimized design and materials**
No liquid remains after filtration, eliminates the need of rinsing

Easy handling

- **Click-Fit closure**
Fast in routine analysis, eliminates the risk of leakage

Economy

- **Adaptable on Combisart®**
Given flexibility, no additional investment required
- **Transparent funnel material**
Visibility of the complete filtration

Specifications

Specifications

Materials	Funnel: Polypropylene Base: Polypropylene Membrane filter: Cellulose Nitrate (C. Ester), Regenerated Cellulose; choice of various colors and grids
Capacity	100 ml, graduations at 20, 50 and 100 ml 250 ml, 50, 100, 200 and 250 ml graduations
Filter diameter	47 mm, prefilter 40 mm (particle testing only)
Filtration area	13.2 cm ²
Max. operating pressure	Vacuum only
Sterilization	Ethylene oxide
Lot certificate	Recovery rate, sterility and performance test

Microsart® @filter 100, sterile disposable filter units with lid, 47 mm, 100 ml, packaged on trays, ideal for the use in clean benches, 24 units

Pore size	Membrane filter* color grid color	Sartorius Stedim Order No.	Fisher Scientific Order No.
0.2	CN white black	16D01--10-07--TG	TBD
0.45, High Flow	CN white black	16D01--10-H6--TG	TBD
0.45, High Flow	CN gray white**	16D03--10-H6--TG	TBD
0.45	CN green dark green	16D02--10-06--TG	TBD
0.45	RC white (w/o grid)	16D05--10-06--TG	TBD

Microsart® @filter 250, sterile disposable filter units with lid, 47 mm, 250 ml, packaged on trays, ideal for the use in clean benches, 16 units

0.2	CN white black	16D01--25-07--TF	TBD
0.45, High Flow	CN white black	16D01--25-H6--TF	TBD
0.45, High Flow	CN gray white**	16D03--25-H6--TF	TBD
0.45	CN green dark green	16D02--25-06--TF	TBD
0.65	CN gray white**	16D03--25-05--TF	TBD

Microsart® @filter 100, sterile disposable filter units, 47 mm, 100 ml, stacked and packaged in bags, ideal for the use with Microsart® Funnel Dispenser, 60 units

0.2	CN white black	16D01--10-07--BL	TBD
0.45, High Flow	CN white black	16D01--10-H6--BL	TBD
0.45, High Flow	CN gray white**	16D03--10-H6--BL	TBD
0.45	CN green dark green	16D02--10-06--BL	TBD
0.45	RC white (w/o grid)	16D05--10-06--BL	TBD

Microsart® @filter 250, sterile disposable filter units, 47 mm, 250 ml, stacked and packaged in bags, ideal for the use with Microsart® Funnel Dispenser, 48 units

0.2	CN white black	16D01--25-07--BK	TBD
0.45, High Flow	CN white black	16D01--25-H6--BK	TBD
0.45, High Flow	CN gray white**	16D03--25-H6--BK	TBD
0.45	CN green dark green	16D02--25-06--BK	TBD
0.65	CN gray white**	16D03--25-05--BK	TBD

Accessories

Description	Sartorius Stedim Order No.	Fisher Scientific Order No.
Microsart® Funnel Dispenser Funnel dispenser for secure removal of single, sterile Microsart® @filter packaged in bags	16A08	TBD

* CN = Cellulose Nitrate (Cellulose ester), RC = Regenerated Cellulose

** Gray membranes after wetting black

Microsart® Funnel 100
Microsart® Funnel 250
Sterile disposable funnels with Click-fit



In microbiological quality control, sterility of the equipment used for processing samples is a necessary basic requirement. The re-useable funnels made of stainless steel or other materials which are used for membrane filtration are usually sanitized between samples by flaming or with hot water. Both of these methods can be insufficiently reliable if not properly performed. Alternatively, the funnels can be sterilized by autoclaving, but this is too laborious for routine use. A disposable filter funnel is the ideal combination for reliability and time saving.

Description

Microsart® Funnels are sterile plastic funnels, which are available for the filtration of various sample volumes. They allow quick performance of the filtration steps required in the routine testing of water, food and beverages, pharmaceutical and cosmetic products.

A Sartorius Stedim Biotech 47 mm gridded membrane is placed on a stainless steel filter support. A Microsart® Funnel is simply and practically fitted on. The sample is filtered.

The funnel is made of polypropylene and thus is elastic enough for optimal sealing with a Click-Fit closure. Graduations are marked to allow accurate sample volumes. The large inner diameter ensures a high flow rate. The optimized shape allows thorough rinsing of the system subsequent to filtration. No liquid is retained in the filter funnel.

Microsart® Base 47 mm

The Microsart® Base 47 mm is the perfect addition to existing Combisart® and Microsart® CombiJet stainless steel manifolds. The slightly recessed frit ensures the plane positioning of the membrane filter. Thus wrinkled membranes, which make the counting of the colony growth difficult, are eliminated. Lateral notches make sure that the membrane can be removed easily after filtration.

Microsart® Funnel Dispenser

The Funnel Dispenser for secure removal of single, sterile Microsart® Funnels has proven itself in practice. Even after opening the bag, the remaining funnels are protected from secondary contamination. The Microsart® Funnel Dispenser is made of high-grade stainless steel, the dispenser opening is made of polypropylene and contains a silicone O-ring. All these materials guarantee reliable autoclaving.

Applications

Colony counting, particle testing and microscopy

Some of the advantages you will benefit from when using Microsart® Funnel 100:

- **Reliable results**
Use a new, sterile funnel for each test for certain prevention of cross contamination!
- **Time-saving**
Just change the funnel, rather than spending time sanitizing it!
- **Simpler handling**
No more holding hot funnels! And, you can see when filtration has been completed, particularly useful when using manifolds in routine testing.

Specifications

Specifications

Material	Polypropylene
Capacity	100 ml, graduations at 20, 50 and 100 ml 250 ml, graduations at 50, 100, 200 and 250 ml
Filter diameter	47 mm, prefilter 40 mm (particle testing only)
Filtration area	13.2 cm ²
Max. operating pressure	Vacuum only
Sterilization	Ethylene oxide
Lot certificate	Sterility and performance test

Microsart® Funnel 100, sterile disposable funnel, 100 ml, 100 units

Description	Sartorius Stedim Order No.	Fisher Scientific Order No.
Microsart® Funnel 100, sterile in 5 sealed bags	16A07--10-----N	14-555-789

Microsart® Funnel 250, sterile disposable funnels, 250 ml, 96 units

Description	Sartorius Stedim Order No.	Fisher Scientific Order No.
Microsart® Funnel 250, sterile in 6 sealed bags	16A07--25-----N	14-555-790

Accessories and replacement parts

Description	Sartorius Stedim Order No.	Fisher Scientific Order No.
Microsart® Funnel Dispenser Funnel dispenser for secure removal of single, sterile Microsart® Funnels	16A08	TBD
Microsart® Base 47 mm, with frit, stainless steel base for Combisart® and Microsart® Combi.jet Optimized for the use with 47 mm membranes, Click-Fit closure for Microsart® Funnel, Microsart® @filter and other funnel types sealed by bayonet closure	1ZU---0002	14-555-784
Silicone O-ring for Microsart® Base 47 mm male thread (pack size 3)	6980274	TBD
Replacement frit for Microsart® Base, stainless steel	1ZU---0001	14-555-783

Further information about Microsart® Combi.jet and Combisart® stainless steel manifolds you will find on the following pages.

Biosart® 250 Funnels



In microbiological quality control, sterility of the equipment used for processing samples is a necessary basic requirement. The reusable funnels made of stainless steel or other materials which are used for membrane filtration are usually sanitized between samples by flaming or with hot water. Both of these methods can be insufficiently reliable when not properly performed. Alternatively, the funnels could be sterilized by autoclaving, but this is too laborious for routine use. A disposable sterile funnel in a certified quality is the ideal solution.

Description

The Biosart® 250 Funnel has been specifically designed for microbiological and analytical quality assurance. Biosart® 250 are sterile funnels which allows for fast filtration required in the routine testing of pharmaceutical and cosmetic products, water, food and beverages and other liquids. A Sartorius Stedim Biotech gridded membrane is placed on a stainless steel filter support. A Biosart® 250 Funnel is simply fitted on and the sample is filtered. The funnel is made of polypropylene and is sufficiently elastic for optimal sealing with a bayonet-type closure. Graduations are marked at 50, 100, 150, 200 and 250 ml for exact sample volumes. The large inner diameter ensures a high flow rate. The conical form allows a thorough rinsing of the system subsequent to filtration. No liquid is retained in the filter funnel.

Applications

Colony counting, particle testing and microscopy

Some of the advantages you will benefit from when using Biosart® 250 Funnels:

Superior performance

- High flow rate
- High total throughput

Safe & reliable

- Sterile or individually, sterile packaged
- No risk of cross contaminations
- No leakages due to proven closure technique
- No holding of hot funnels
- Visibility of the complete filtration

Economical

- Ready to connect and easy to use
- Minimal amount of equipment needed
- Autoclavable (to a limited extend)

Specifications

Material	Polypropylene
Capacity	250 ml, 50 ml graduations
Filter diameter	47 mm (or 50 mm), prefilter 40 mm
Filtration area	12.5 cm ²
Max. operating pressure	Vacuum only
Sterilization	Ethylene oxide
Lot certificates	Sterility and performance tests

Biosart® 250 Funnels, ready to use filter funnels, 250 ml, 50 units

Description	Sartorius Stedim Order No.	Fisher Scientific Order No.
Biosart® 250 Funnel, 50 units, individually, sterile-packaged	16407--25----ACK	14-555-761
Biosart® 250 Funnel, 50 units, sterile-packaged	16407--25----ALK	14-555-762

Further information available on request f.o.c. Order no. SL-3017-e

Combisart® – The Sterile Vented Filter Station Individual and Multi-Branch Systems



The Sartorius Stedim Biotech Combisart®, system enables you to select the optimal hardware and consumables for your needs in microbiological analysis or particle count in quality assurance. Combisart® features a modular design and field-proven standard accessories to make your choice easier.

Description

At the heart of the Combisart® system is a high-grade stainless steel manifold or individual system designed to accommodate all types of filter holders and funnels such as:

- Ready-to-use units like Microsart® Funnels 100 and 250, Microsart® @filter 100 and 250, Biosart® 100 Monitors and Biosart® 250 Funnels
- Flammable units such as stainless steel funnels for colony counting
- Autoclavable reusable funnels made of glass or polycarbonate



The outlet of the 1- and 3-branch manifolds are newly Quick Connection Nipples, which could be used together with Quick Connection Couplings (more information under Microsart® Combi.jet) or as hose nipples for vacuum tubings. The low height of the manifold ports is particularly advantageous for working on a clean bench. For low number of samples, we recommend the use of the 1-branch manifold Sartorius Stedim Order No. 16844 | Fisher Scientific Order No. 14-555-802 or the individual base Sartorius Stedim Order No. 16841 | Fisher Scientific Order No. 14-555-799 on the top of a suction flask. For large number of samples, we recommend the 3- or 6-branch manifolds.



Sterile venting

A special feature of the Combisart® system is the stainless steel three-way valve (tap). They allow the vacuum for each filter holder to be individually controlled and each filter station to be sterilely vented. This rules out secondary contamination of the underside of the filter.

Sterilization

The system is compliant with ISO 8199 with regards to the sterilization methods of the equipment described in the "General Guide to enumeration of micro-organisms by culture". Since the most reliable sterilization method is autoclaving, the Combisart® design offers a unique advantage for this method. After inserting the membrane filters in the filter holders, you can simply unscrew them as an entire unit from each workstation and autoclave them. This method increases reliability and saves sterilization capacity.

The right equipment for your application

In connection with the single base Sartorius Stedim Order No. 16840 | Fisher Scientific Order No. 14-555-798 (for 50 mm membranes) the manifolds are flexible to adapt disposable Biosart® 250 or stainless steel funnels. The stainless steel filter support of the single base 16840 | 14-555-798 allows a homogenous distribution of the residues on the membrane filter surface. Alternatively to 16840 | 14-555-798 the Microsart® Base 47 mm is highly recommended for all 47 mm membrane filters, Microsart® Funnels and for Microsart® @filter.

The Biosart® 100 adapter Sartorius Stedim Order No. 16424 | Fisher Scientific Order No. TBD ensures that the Monitors are positioned perfectly, minimizing the risk of contamination during filtration.

3 or 6 polycarbonate holders of the Sartorius Stedim type 16511 | Fisher Scientific type 14-555-805 can be screwed onto the manifold directly.

Glass units (Sartorius Stedim Order No. 16306 or 16307 | Fisher Scientific Order No. 14-555-544 or 14-555-810) can be fitted by using corresponding adapter-|stopper-combinations.

Maximum flexibility

The turnable single base for 50 mm membranes 16840 | 14-555-798 or the Microsart® Base 47 mm features additional advantages you will benefit from:

- You can pour out a non-filterable sample from each unit
- Filtration equally easy for left- or right-handed users in your laboratory, because funnels can be positioned to suit the individual user

Some of the advantages you will benefit from when using the Combisart® System:

Safe & reliable

- Sterile venting of each membrane after filtration
- Sterilization acc. to ISO 8199
- Special polished stainless steel surfaces allow easy cleaning & rinsing
- Low height is advantageous for working on a clean bench

Saves time

- Filtration of 3 or 6 samples in parallel
- Easy pouring out of non-filterable samples
- Equally easy for right- and left-handed users

Economical

- Maximum flexibility due to different set-ups
- Space-saving in the autoclave
- Stainless steel 304 – long lifecycle

Combisart® hardware-setups

Filtration systems fast and easy completed at www.sartorius-stedim.com/microbio

Specifications

Stainless steel quality	High-grade stainless steel: B.S. 304S31 AISI 304
Dimensions in mm (L H D)	3-branch manifold: 435 103 120 6-branch manifold: 910 103 120
Max. operating pressure	Vacuum only
Sterilization	By autoclaving (max. 134°C), By dry heat (max. 180°C), By flaming, By other methods acc. to ISO 8199
Parts and materials	Lid, funnel, base part, filter support, clamp and tap made of stainless steel. Silicone flat gasket. Silicone lid seal
Flow rate per filter station for water at 90% vacuum	200 ml/min with 0.2 µm membrane filter 600 ml/min with 0.45 µm membrane filter
Filtration area	12.5 cm ² (if using stainless steel funnels)
Suitable membrane filter diameter	50 mm (47 mm, if using a 47 mm frit Sartorius Stedim Order No. 6980103 Fisher Scientific Order No. 14-555-920)
Outlet spout (individual system)	10 mm outer diameter
Inlet (branches only)	Female thread, TR 20×2
Outlet (1- and 3-branches only)	Quick Connection Nipple DN 7 (tubings with DN 10 are connectable)
Outlet (6-branch)	Hose nipple DN 10

Combisart® individual system and multi-branch manifolds, made of high-grade stainless steel, pre-assembled with stainless steel funnels and lids

Description	Capacity	Sartorius Stedim Order No.	Fisher Scientific Order No.
Combisart® individual filter holder, stainless steel, 100 ml	1 × 100 ml	16219-CS	TBD
Combisart® individual filter holder, stainless steel, 500 ml	1 × 500 ml	16201-CS	14-555-813
Combisart® 1-branch stainless steel manifold, 100 ml	1 × 100 ml	16844-CS	14-555-803
Combisart® 1-branch stainless steel manifold, 500 ml	1 × 500 ml	16845-CS	TBD
Combisart® 3-branch stainless steel manifold, 100 ml	3 × 100 ml	16824-CS	TBD
Combisart® 3-branch stainless steel manifold, 500 ml	3 × 500 ml	16828-CS	14-555-794
Combisart® 6-branch stainless steel manifold, 100 ml	6 × 100 ml	16832-CS	TBD
Combisart® 6-branch stainless steel manifold, 500 ml	6 × 500 ml	16831-CS	TBD

Combisart® individual and multi-branch bases, made of high-grade stainless steel, without funnels and lids, to accommodate various funnel types

Description	Sartorius Stedim Order No.	Fisher Scientific Order No.
Combisart® individual base, stainless steel, with frit (50 mm), to accommodate stainless steel funnels and Biosart® 100 250	16841	14-555-799
Combisart® 1-branch stainless steel manifold, without frit	16844	14-555-802
Combisart® 3-branch stainless steel manifold, without frits	16842	14-555-800
Combisart® 6-branch stainless steel manifold, without frits	16843	14-555-801
Combisart® Single base with frit (for 50 mm membranes), stainless steel, accommodate stainless steel funnels and Biosart® 100 250	16840	14-555-798
Microsart® Base 47 mm, with frit, stainless steel base for Combisart® and Microsart® Combi.jet Optimized for the use with 47 mm membranes, Click-Fit closure for Microsart® Funnel, Microsart® @filter and other funnel types sealed by bayonet closure	1ZU---0002	14-555-784

Combisart® Hardware Set-Ups – Choose complete filtration systems easy and fast under: <http://www.sartorius-stedim.com/microbio>

Replacement parts for Combisart® individual filter holders

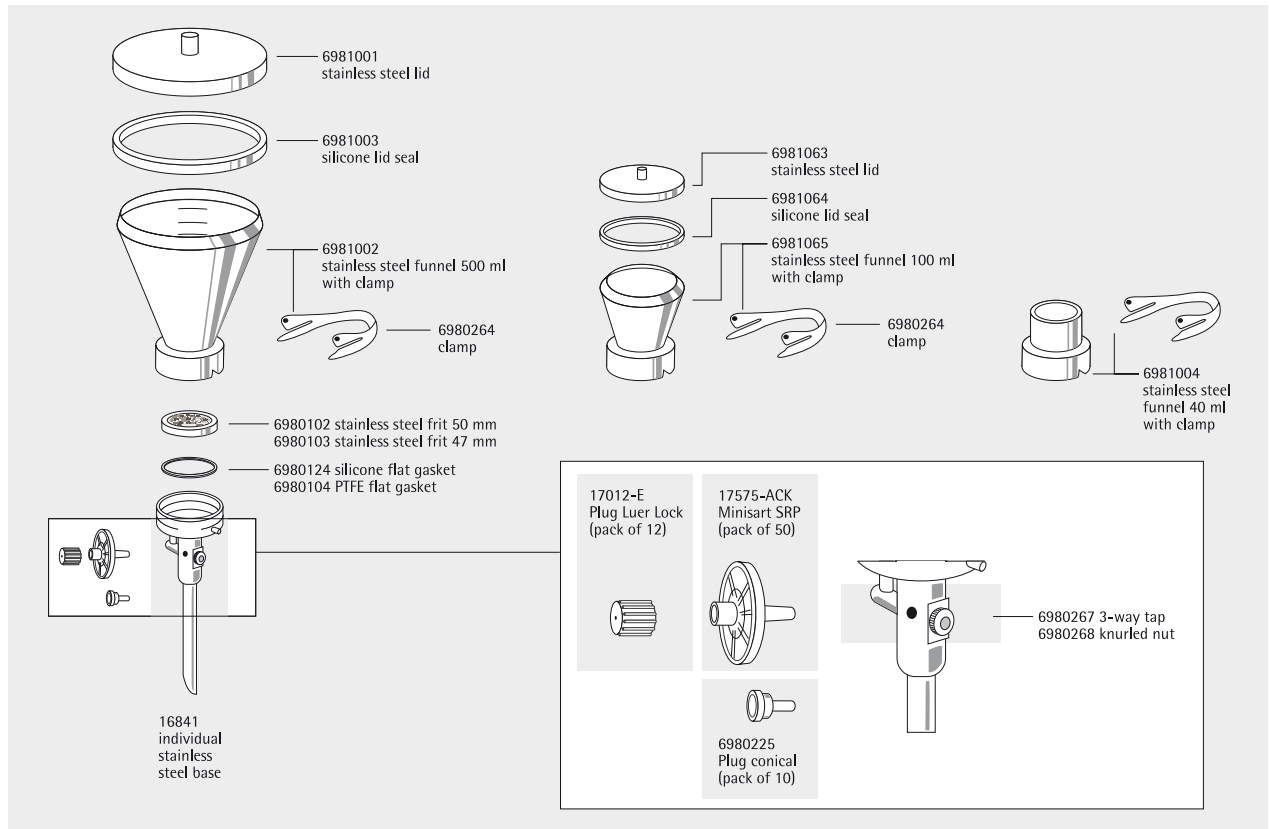

Replacement parts for Combisart® manifolds

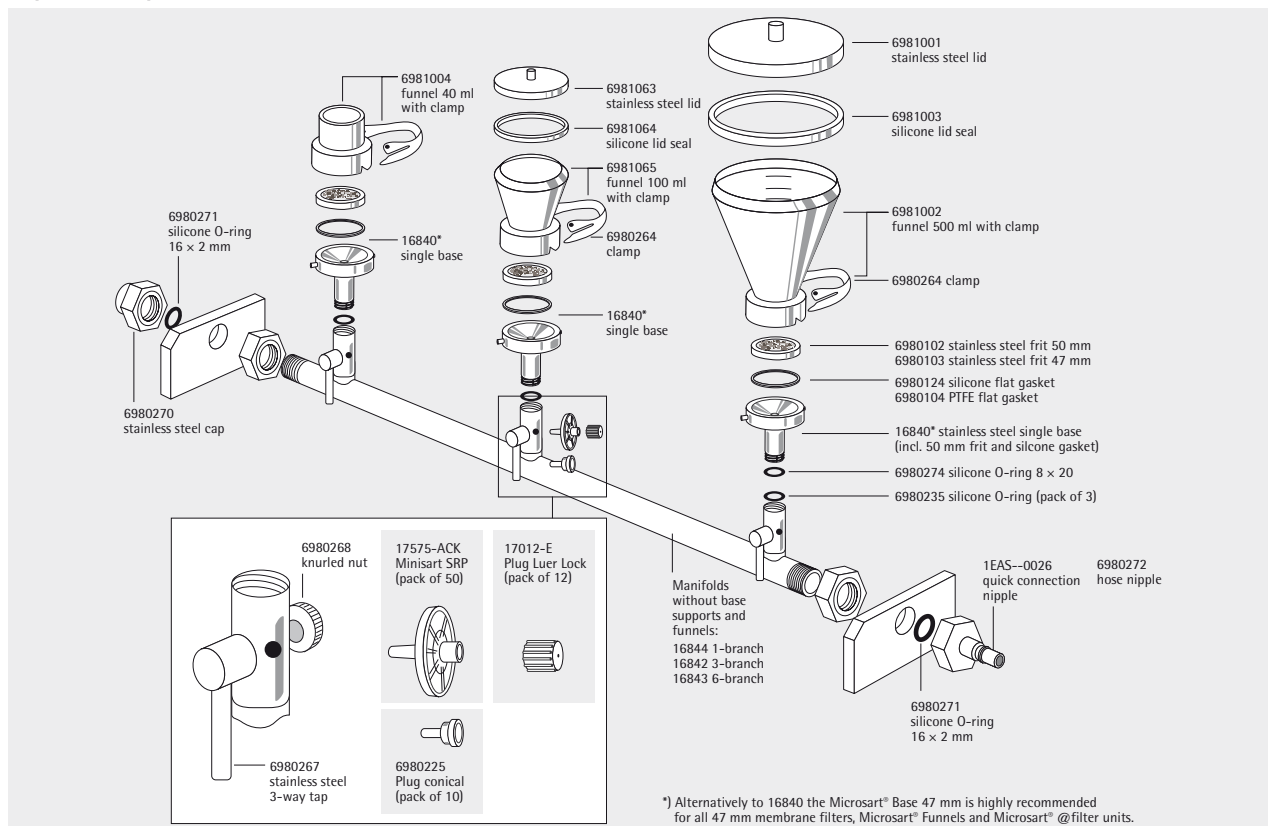

Accessories and replacement parts for the Combisart® System

Description	Quantity	Sartorius Stedim Order No.	Fisher Scientific Order No.
Minisart® SRP25, sterile filter for venting, 0.2 µm, individually sterile-packaged, could be autoclaved 5 times.	50	17575-----ACK	14-555-296
Plug luer lock, to close the Minisart® inlet, if sterile venting is not required	12	17012-----E	14-555-863
Plug, conical, to close the venting hole beside the 3-way-valve, if sterile venting is not required	10	6980225	14-555-925
Silicone O-ring for single base 16840 14-555-798 male thread (also 1ZU---0002 14-555-784)	3	6980274	TBD
Silicone O-ring for manifold female threads	3	6980235	14-555-934
Silicone flat gasket underneath the frit (16840 14-555-798)	1	6980124	14-555-924
PTFE flat gasket underneath the frit (16840 14-555-798)	1	6980104	14-555-921
Stainless steel frit, 50 mm diameter (16840 14-555-798)	1	6980102	14-555-919
Stainless steel frit, 47 mm diameter (16840 14-555-798)	1	6980103	14-555-920
Quick Connection Nipple, stainless steel	1	1EAS--0026	TBD
Hose nipple, stainless steel, DN 10	1	6980272	TBD
Stainless steel frit for Microsart® Base 47 mm (1ZU---0002 14-555-784)	1	1ZU---0001	14-555-783

Funnels, lids, seals and filter holders to connect on the Combisart® system

Description	Capacity	Membrane filter diameter	Sartorius Stedim Order No.	Fisher Scientific Order No.
Stainless steel funnel with closure clamp	100 ml	47 50 mm	6981065	14-555-953
Lid, stainless steel	for 100 ml funnel		6981063	14-555-951
Lid seal, silicone	for 100 ml funnel		6981064	14-555-952
Stainless steel funnel with closure clamp	500 ml	47 50 mm	6981002	14-555-948
Lid, stainless steel	for 500 ml funnel		6981001	14-555-947
Lid seal, silicone	for 500 ml funnel		6981003	14-555-949
Stainless steel funnel with closure clamp	40 ml	47 50 mm	6981004	14-555-950
Polycarbonate filter holder, complete with filter support and funnel	250 ml	47 mm	16511	14-555-805
Glass filter holder, complete with filter support, funnel and metal clamp	30 ml	25 mm	16306	14-555-544
Glass filter holder, complete with filter support, funnel and metal clamp	250 ml	47 50 mm	16307	14-555-810

Combisart® Adapter, to accommodate various funnel types

Description	Adaptation	Sartorius Stedim Order No.	Fisher Scientific Order No.
Biosart® 100 Adapter, silicone	Biosart® 100 Monitors onto Sartorius Stedim Order No. 16840 Fisher Scientific Order No. 14-555-798 (Combisart® single base) or onto Sartorius Stedim Order No. 16841 Fisher Scientific Order No. 14-555-799 (individual base)	16424	TBD
Biosart® 100 Adapter, stainless steel with silicone stopper	Biosart® 100 Monitors onto Combisart® manifolds Sartorius Stedim Order No. 16844, 16842 and 16843 Fisher Scientific Order No. 14-555-802, 14-555-800 and 14-555-801	16835	14-555-781
Glass funnel Adapter, stainless steel with silicone stopper	Sartorius Stedim Order No. 16306/15 Fisher Scientific Order No. 14-555-544/-547 (glass funnel, 30 ml) onto Combisart® manifolds Sartorius Stedim Order No. 16844, 16842 and 16843 Fisher Scientific Order No. 14-555-802, 14-555-800 and 14-555-801	16836	14-555-807
Glass funnel Adapter, stainless steel with silicone stopper	Sartorius Stedim Order No. 16307 Fisher Scientific Order No. 14-555-810 (glass funnel, 250 ml) onto Combisart® manifolds Sartorius Stedim Order No. 16844, 16842 and 16843 Fisher Scientific Order No. 14-555-802, 14-555-800 and 14-555-801	16837	14-555-808

Microsart® Combi.jet 2-branch stainless steel manifold for microbiological analysis



The Microsart® Combi.jet is a 2-branch manifold, made of high-grade stainless steel. The manifold has been specifically designed for the use together with the Microsart® e.jet Transfer Pump. The system is able to create sufficient vacuum for vacuum filtration concomitantly transferring the filtered liquid directly to waste. Microsart® Combi.jet and Microsart® e.jet can be easily connected and disassembled by the innovative Quick Connection technology.

Compact Design

The complete traditional equipment, such as connectors, tubes, suction flask, protection filter, Woulff's bottle and a vacuum pump, requires a lot of laboratory space and is time consuming to operate and maintain. Microsart® Combi.jet reduces operating complexity due to its small and compact design. The Transfer Pump Microsart® e.jet fits visually and ergonomically into this design.

Quick Connection

Building-up the vacuum filtration system is easy and fast thanks to the innovative Quick Connection Coupling and Nipples at the Microsart® Combi.jet manifold and Microsart® e.jet Transfer Pump. Simply push-to-connect for assembling and pull-to-disassembling the whole system within seconds.

Sterile Venting

A special feature of the Microsart® Combi.jet manifold are the stainless steel three-way valves (taps). They allow the vacuum for each filter holder to be individually controlled and each filter station to be sterilely vented. This rules out secondary contamination of the underside of the filter.

Maximum Flexibility

The Microsart® Combi.jet enables you to select the optimal hardware and consumables for your needs in microbiological analysis in quality assurance. At the heart of the whole system is the Microsart® Combi.jet, the stainless steel 2-branch manifold, designed to accommodate all types of filter holders and funnels such as:

- Ready-to-use units Microsart® @filter 100 and 250
- Ready-to-use units Microsart® Funnel 100 and 250
- Ready-to-use units Biosart® 100 Monitors
- Ready-to-use units Biosart® 250 Funnels
- Flammable units such as stainless steel funnels
- Autoclavable glass filter holders
- Autoclavable polycarbonate filter holder

Reliability: Ideal for microbiology applications

- Sterile venting after filtration
- Easy to clean and sanitize
- Smooth and reliable filtration

Economically efficient

- Saving time due to Quick Connection technology
- Saving work space (saves 70%)
- No need of suction flasks and water traps

Specifications

Stainless steel quality	High-grade stainless steel: B.S. 304S31 AISI 304
Dimensions in mm (L H D)	246 98 130
Max. operating pressure	Vacuum only
Sterilization	By autoclaving (max. 134°C)
Parts and materials	Manifold: stainless steel, silicone O-ring
Quick Connection Coupling	PVDF, closure: stainless steel, sealing: FKM FPM
Inlet (manifold)	Female thread, TR 20×2
Outlet	Quick Connection Coupling (female), inner diameter NW 7, non-shut-off

Microsart® Base 47 mm

Materials	stainless steel, silicone O-ring
Suitable membrane filter diameter	47 mm
Filtration area (e. g. for the use with Microsart® Funnels)	12.5 cm ²

Microsart® Combi.jet 2-branch manifold, made of high-grade stainless steel, without frits and funnels, to accommodate various funnel types

Description	Sartorius Stedim Order No.	Fisher Scientific Order No.
Microsart® Combi.jet 2-branch manifold, without frits	16848-CJ	TBD
Microsart® Base 47 mm, with frit, stainless steel base for Combisart® and Microsart® Combi.jet Optimized for the use with 47 mm membranes, Click-Fit closure for Microsart® Funnel, Microsart® @filter and other funnel types sealed by bayonet closure	1ZU---0002	14-555-784

Accessories and replacement parts for Microsart® Combi.jet

Description	Quantity	Sartorius Stedim Order No.	Fisher Scientific Order No.
Minisart® SRP25, sterile filter for venting, 0.2 µm, individually sterile-packaged, could be autoclaved 5 times.	50	17575-----ACK	14-555-296
Plug luer lock, to close the Minisart® inlet, if sterile venting is not required	12	17012-----E	14-555-863
Plug, conical, to close the venting hole beside the 3-way-valve, if sterile venting is not required	10	6980225	14-555-925
Silicone O-ring for Microsart® Base 47 mm male thread	3	6980274	TBD
Silicone O-ring for manifold female threads	3	6980235	14-555-934
Combisart® single base, stainless steel, optimal for the use with 50 mm membrane filters, funnel closure by bayonet or adapter	1	16840	14-555-798
Microsart® Combi.jet Coupling, Quick Connection, PVDF	1	1EAS--0022	TBD

Funnels and filter holders to connect onto the Microsart® Combi.jet manifold are equivalent to those for the use with the Combisart® system (page 38).

How to set-up a vacuum filtration system

Microsart® Combi.jet 2-branch Stainless Steel Manifold plus Microsart® e.jet

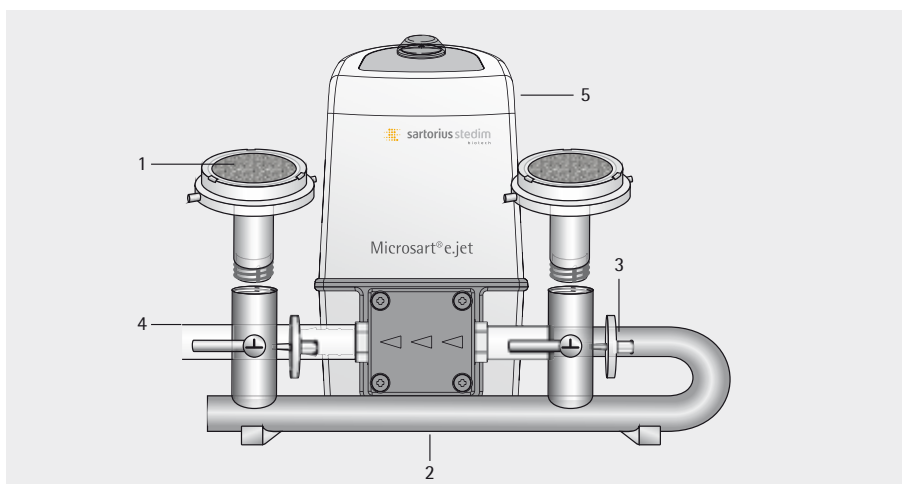

The filter stations are directly connected to a Transfer Pump for simultaneous transfer of the filtrate to waste. Easy assembling thanks to Quick Connection technology.

Order Information

Pos.	Description	Order Qty.	Sartorius Stedim Order No.	Fisher Scientific Order No.	Detailed Information on page
Microsart® Combi.jet stainless steel equipment:					43
1	Microsart® Base 47 mm	2	1ZU---0002	14-555-784	
2	Microsart® Combi.jet 2-branch manifold	1	16848-CJ	TBD	
Sterile venting of the filter station:					41
3	Minisart® SRP25, 0.2 µm	1	17575-----ACK	14-555-296	
4	Silicone tubing, pressure-sided, 1 m	2*	1ZAS--0007	TBD	54
Vacuum Pump:					53
5	Microsart® e.jet Transfer Pump, 230 V, 50 Hz	1	166MP-4	TBD	
Additional accessories:					
	Microsart® @filter 100, sterile filter units, packaged on trays	1	16D01--10-H6--TG	TBD	33
	Stainless steel tweezers	1	16625	14-555-897	56
	Colony Counter	1	17649	14-555-825	56
	Incubator	1	18113	TBD	56
	Container for anaerobic incubation	1	16671	TBD	57

* required length depends on distance between Transfer Pump and drain

Combisart® 1-branch Stainless Steel Manifold plus Microsart® mini.vac

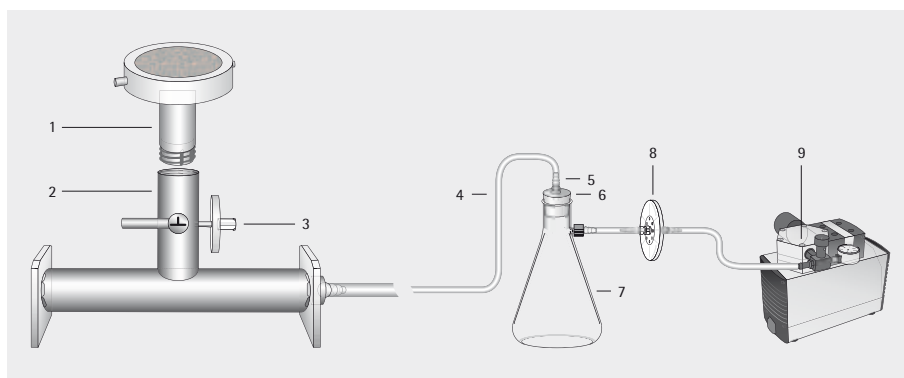

The filter station is connected to a suction flask, which is connected to a filtrate-protected vacuum pump.

Order Information

Pos.	Description	Order Qty.	Sartorius Stedim Order No.	Fisher Scientific Order No.	Detailed Information on page
Combisart® stainless steel equipment:					38
1	Combisart® single base, 50 mm	1	16840	14-555-798	
2	Combisart® 1-branch manifold	1	16844	14-555-802	
Sterile venting of the filter station:					41
3	Minisart® SRP25, 0.2 µm	1	17575-----ACK	14-555-296	
4	Rubber vacuum hose, 1 m	3*	16623	14-555-549	51
Suction flask and stopper:					50
5	Tube connector	1	17204	14-555-908	
6	Silicone stopper	1	17173	14-555-820	
7	Suction flask, 2 liters	1	16672	14-555-898	
Water trap for pump protection:					51
8	Vacusart®, 0.45 µm	1	17804-----M	TBD	
Vacuum Pump:					52
9	Microsart® mini.vac, 230 V, 50 Hz	1	16694-2-50-06	TBD	
Additional accessories:					
	Microsart® e.motion Dispenser	1	16712	14-555-785	14
	Stainless steel tweezers	1	16625	14-555-897	56
	Colony Counter	1	17649	14-555-825	56
	Incubator	1	18113	TBD	56
	Stainless steel prefilter attachment	1	16807	14-555-907	57
	Container for anaerobic incubation	1	16671	TBD	57

* required length depends on distance between the filter station and the vacuum source

Combisart® 1-branch Stainless Steel Manifold plus Microsart® e.jet

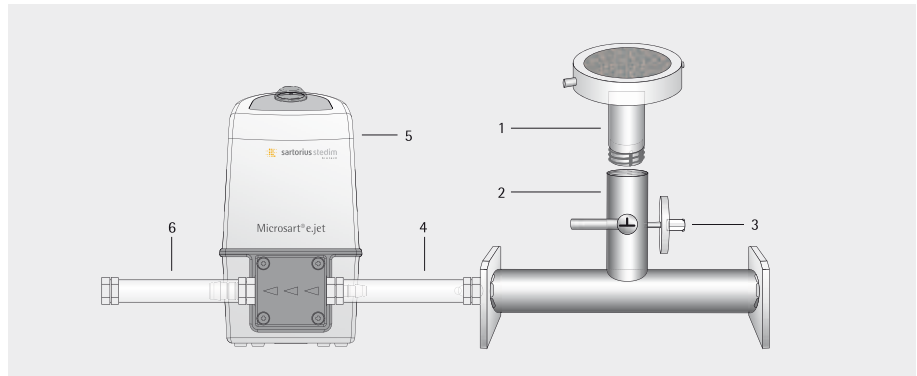

The filter station is directly connected to a vacuum fluid pump for simultaneous transfer of the filtrate to waste. Easy assembling thanks to Quick Connection technology.

Order Information

Pos.	Description	Order Qty.	Sartorius Stedim Order No.	Fisher Scientific Order No.	Detailed Information on page
Combisart® stainless steel equipment:					38
1	Combisart® single base, 50 mm	1	16840	14-555-798	
2	Combisart® 1-branch manifold	1	16844	14-555-802	
Sterile venting of the filter station:					41
3	Minisart® SRP25, 0.2 µm	1	17575-----ACK	14-555-296	
Silicone tubing with Quick Connection Coupling, 20 cm, vacuum-sided					54
4		1	1ZA---0006	TBD	
Vacuum Pump:					53
5	Microsart® e.jet Transfer Pump	1	166MP-4	TBD	
Silicone tubing, pressure-sided 1 m					54
6		2*	1ZAS--0007	TBD	
Additional accessories:					
	Microsart® e.motion Dispenser	1	16712	14-555-785	14
	Stainless steel tweezers	1	16625	14-555-897	56
	Colony Counter	1	17649	14-555-825	56
	Incubator	1	18113	TBD	56
	Stainless steel prefilter attachment	1	16807	14-555-907	57
	Container for anaerobic incubation	1	16671	TBD	57

* required length depends on distance between vacuum source and drain

Traditional Multi-Branch Manifolds and Individual Filter Holders Made of Stainless Steel, Glass and Polycarbonate



Individual filter holders

The three stainless steel holder types differ only in the funnel capacity (either 40 ml, 100 ml or 500 ml). They have been designed specifically for applications in which the particles or microorganisms retained on the membrane filter surface are of interest. The stainless steel frit filter support ensures a uniform distribution of the residues. Simple handling is very important regarding routine examinations. Stainless steel taps in the base allow the vacuum to be turned on and off. The special closure clamps simplify the addition or removal of the funnels adding to the ease of use.



Multi-branch manifolds

The manifold systems are available with 100 ml or 500 ml capacity funnels. The three or six separate filter holders save time when mass examinations have to be carried out. Due to the stainless steel taps on the manifold ports, the vacuum for each holder can be turned on and off individually. The stainless steel frit allows homogenous distribution of the residues on the membrane filter surface. Funnel and filter support can be disinfected by flaming.



Glass filter holders

These filter holders are available for the filtration of small volumes with a 30 ml top part and for larger volumes with a 250 ml top part. They can be sterilized by autoclaving (max. 134°C) or by dry heat (max. 180°C). The glass frit ensures uniform distribution of retained residue.

Polycarbonate filter holders

Sartorius Stedim Type 16510 | Fisher Scientific Type 14-555-804 is complete with receiver flask, and can be operated with vacuum as well as with slight overpressure (0.5 bar is recommended for highest standing times). Type 16511 | 14-555-805 is like 16510 | 14-555-804, but without receiver flask. It is used on a suction flask or a vacuum manifold e. g. Combisart® systems. Both devices can be sterilized by autoclaving (max. 121°C).

Specifications

Stainless steel multi-branch manifolds and individual filter holders

Stainless steel quality	High-grade stainless steel: B.S. 304S31 AISI 304
Dimensions in mm (W H D)	3-branch manifold: 3 × 100 ml: 432 184 120 3 × 500 ml: 442 262 132 6-branch manifold: 6 × 100 ml: 906 268 120 6 × 500 ml: 916 329 132
Max. operating pressure	Vacuum or max. 2 bar pressure (29 psi)
Sterilization	By autoclaving (max. 134°C), By dry heat (max. 180°C), By flaming, By other methods acc. to ISO 8199
Parts and materials	Lid, funnel, base part, – filter support, clamp and tap made of stainless steel. Silicone flat gasket. Silicone lid seal
Flow rate per filter station for water at 90% vacuum	200 ml/min with 0.2 µm membrane filter 600 ml/min with 0.45 µm membrane filter
Filtration area	12.5 cm ²
Suitable membrane filter diameter	50 mm (47 mm, if using a 47 mm frit filter support Sartorius Stedim Order No. 6980103 Fisher Scientific Order No. 14-555-920)
Outlet spouts (individual system)	10 mm outside diameter
Outlet (branches only)	Hose nipple, DN 10

Replacement parts for traditional individual filter holders

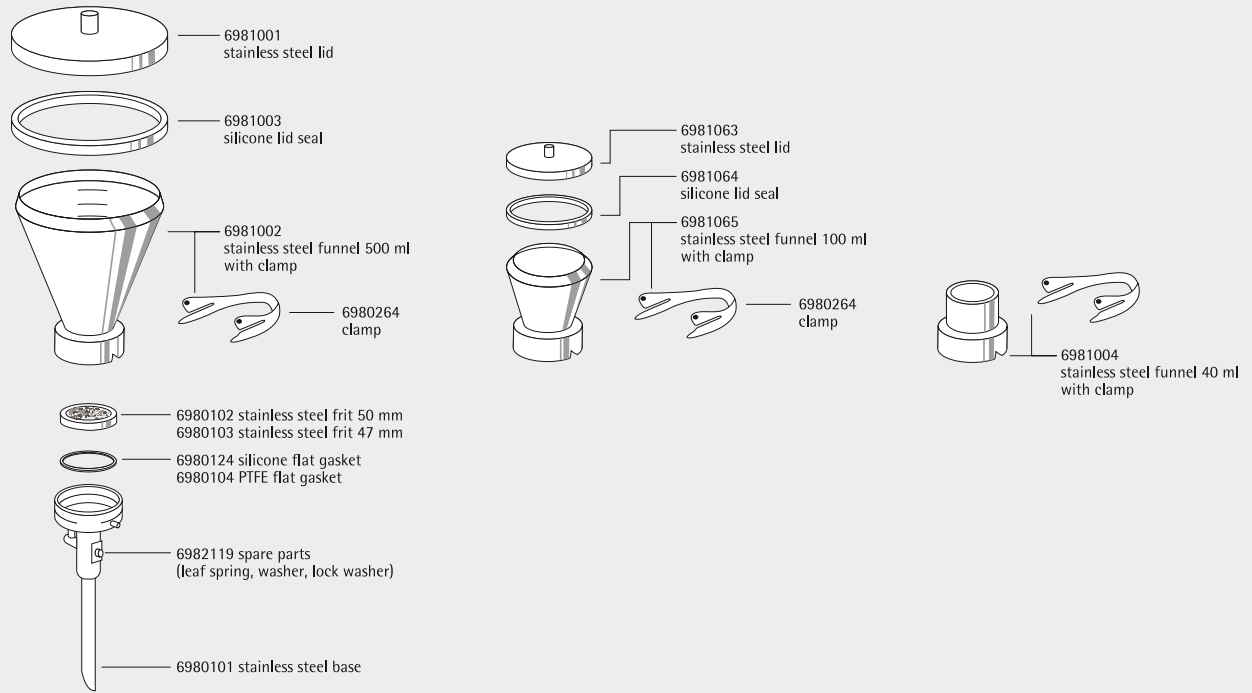

Replacement parts for traditional manifolds

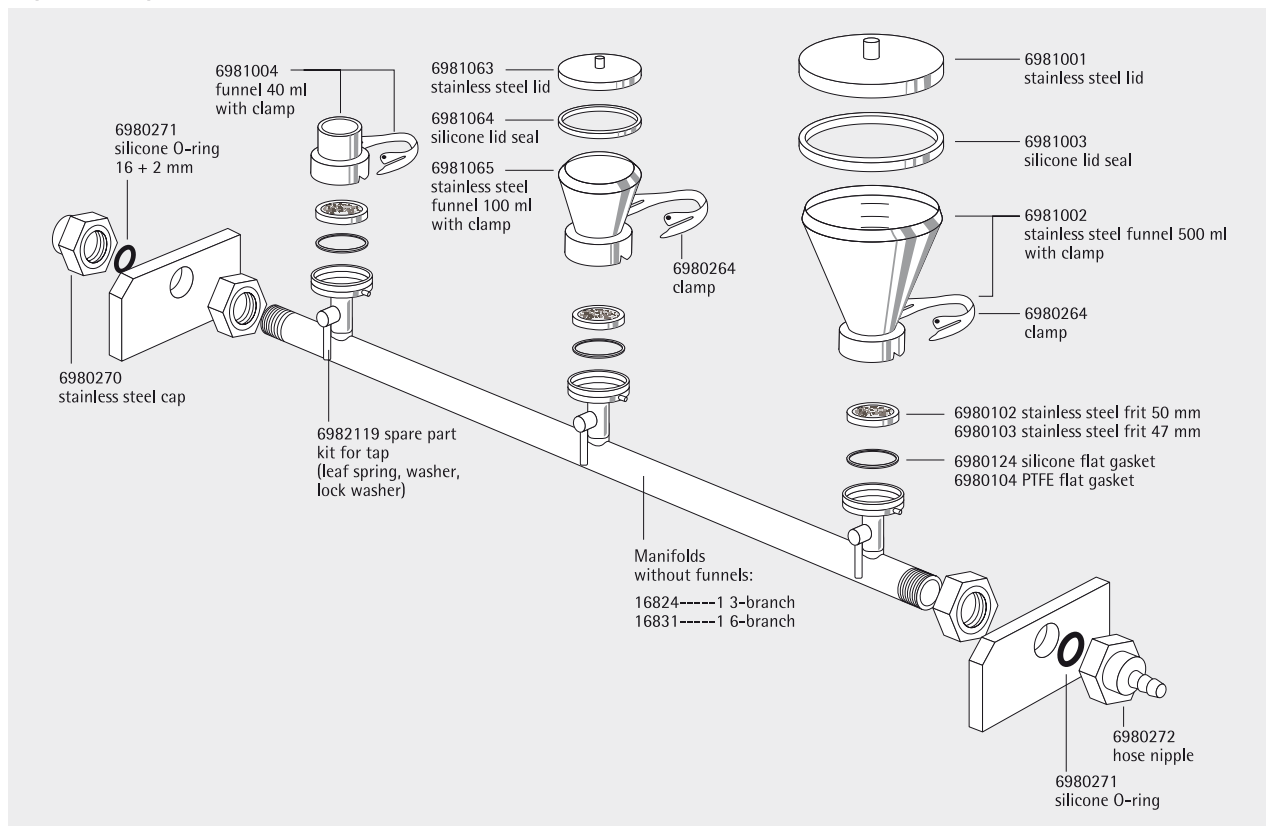

Individual stainless steel filter holders, pre-assembled with stainless steel funnels and lids

Description	Capacity	Sartorius Stedim Order No.	Fisher Scientific Order No.
Individual stainless steel filter holder, 100 ml	1 × 100 ml	16219	14-555-815
Individual stainless steel filter holder, 500 ml	1 × 500 ml	16201	14-555-811
Individual stainless steel filter holder without lid, 40 ml	1 × 40 ml	16220	14-555-816

Multi-branch manifolds, stainless steel, with stainless steel funnels and lids

Description	Capacity	Sartorius Stedim Order No.	Fisher Scientific Order No.
3-branch stainless steel manifold, 100 ml	3 × 100 ml	16824	14-555-791
3-branch stainless steel manifold, 500 ml	3 × 500 ml	16828	14-555-793
6-branch stainless steel manifold, 100 ml	6 × 100 ml	16832	14-555-797
6-branch stainless steel manifold, 500 ml	6 × 500 ml	16831	14-555-796

Glass filter holders

Description	Capacity	Membrane filter diameter	Sartorius Stedim Order No.	Fisher Scientific Order No.
Glass filter holder, complete with filter support, funnel and metal clamp	30 ml	25 mm	16306	14-555-544
Glass filter holder, complete with filter support, funnel and metal clamp	250 ml	47 50 mm	16307	14-555-810

Polycarbonate filter holder

Description	Capacity	Membrane filter diameter	Sartorius Stedim Order No.	Fisher Scientific Order No.
Polycarbonate filter holder, with 250 ml top part and receiver flask, for vacuum or pressure filtration	250 ml	47 mm	16510	14-555-804
Polycarbonate filter holder, with 250 ml top part, for vacuum filtration only	250 ml	47 mm	16511	14-555-805

Accessories for Vacuum Filter Holders and Manifold Systems



Suction flasks and stoppers

Suction flask, 2 liter capacity

Vacuum-resistant flask made of duran 50 glass with plastic safety hose nipple according to the – German Industrial Standard No. 12476. Outer diameter of the hose nipple, 9 mm. Inner diameter of the opening, 60 mm. Stoppers are not enclosed.

A 1-liter capacity flask is available for countries which do not have safety restrictions on glass hose nipples.

Order numbers for Suction flasks

Description	Sartorius Stedim Order No.	Fisher Scientific Order No.
Suction flask, 5 liters acc. to DIN 12476, incl. stopper 75 D and glass tube	16672-----1	14-555-899
Suction flask, 2 liters acc. to DIN 12476, without stopper	16672	14-555-898
Tube connector for connecting a Combisart® stainless steel manifold to a suction flask 1 or 2 liters (not necessary when a Vacusart® is connected directly to the bored stopper)	17204	14-555-908
Suction flask, 1 liter (not available in countries which have safety restrictions on glass hose nipples)	16606	14-555-892

Replacement parts for suction flasks

Glass tube for silicon stopper 75 D for suction flask 5 liters 16672-----1 14-555-899	1EAQ--0017	TBD
Bored stopper 75 D for suction flask 5 liters 16672-----1 14-555-899	1EAS--0019	TBD
Assembling kit for hose barb for suction flask 5 liters 16672-----1 14-555-899	1EA---0018	14-555-915
Hose barb, complete, Polypropylene, for suction flask 2 liters 16672 14-555-898	6983003	TBD

Order numbers for bored stoppers for suction flask 2 liters

Sartorius Stedim Order No. 16672 | Fisher Scientific Order No. 14-555-898

Description	Adaptation	Sartorius Stedim Order No.	Fisher Scientific Order No.
Silicone stopper	Combisart® individual base 16841 14-555-799 or other individual stainless steel filter holders (16201 14-555-811, 16219 14-555-815, 16220 14-555-816) onto the suction flask 16672 14-555-898	17173	14-555-820
Silicone stopper	16306/15 14-555-544/-547 (glass funnels, 30 ml) onto the suction flask 16672 14-555-898	17174	14-555-821
Silicone stopper	16307 14-555-810 (glass funnel, 250 ml) onto the suction flask 16672 14-555-898	17175	14-555-822

Order numbers for bored stoppers for suction flask 1 liter

Sartorius Stedim Order No. 16606 | Fisher Scientific Order No. 14-555-892

Silicone stopper	Combisart® individual base 16841 14-555-799 or other individual stainless steel filter holders (16201 14-555-811, 16219 14-555-815, 16220 14-555-816) onto the suction flask 16606 14-555-892	17004	TBD
Silicone stopper	16306/15 14-555-544/-547 (glass funnels, 30 ml) onto the suction flask 16606 14-555-892	17005	14-555-818
Silicone stopper	16307/16 14-555-810/-548 (glass funnel, 250 ml) onto the suction flask 16606 14-555-892	17006	14-555-819

Water traps

Used between suction flask and vacuum source, in order to prevent overflow of filtrate into an electric vacuum pump



Vacusart®

Vacusart® is a ready-to-connect filtration unit, consisting of a polypropylene housing and a hydrophobic, but air-permeable PTFE membrane with a pore size of 0.45 µm. Vacusart® is perfectly suitable for the protection of vacuum pumps. It could be put directly into the hole of the bored stopper and connected with the rubber hose to the vacuum pump.

Description	Sartorius Stedim Order No.	Fisher Scientific Order No.
Vacusart® water trap, pack of 3	17804-----M	TBD



Woulff's bottle, 500 ml

Used between suction flask and vacuum source. Allows simple control of the vacuum with glass units without a separate tap and prevents furthermore the filtrate from overflowing from the suction flask.

Description	Sartorius Stedim Order No.	Fisher Scientific Order No.
Woulff's bottle, 500 ml	16610	14-555-893



Rubber vacuum hose (1 meter)

Thick-walled rubber hose for connecting the system components, e. g. suction flasks, vacuum pumps, etc. When ordering, please state length required in meters.

Description	Sartorius Stedim Order No.	Fisher Scientific Order No.
Rubber vacuum hose (1 meter)	16623	14-555-549

Electric vacuum pumps



Microsart® mini.vac

Microsart® maxi.vac

Neoprene membrane pumps with low noise level, oil- and maintenance-free; reliable sources of vacuum.

The new vacuum pump series provides up to date technology for daily use in the Microbiology laboratory environment.

The vacuum produced by the new pumps is controlled and can be easily adjusted to your specifications. Thus damageable cells (e.g. bacteria) are concentrated on the surface or a membrane filter under better conditions, which results in decreased sub lethals, higher recovery rates and shorter incubation times.



Specifications of electric vacuum pumps

	Microsart® maxi.vac	Microsart® mini.vac
Sartorius Stedim Order No.	16694-1-60-22	16694-1-60-06
Fisher Scientific Order No.	14-555-788	14-555-787
Delivery	22 l/min	6 l/min
Ultimate Vacuum	100 mbar	100 mbar
Noise level [100 mbar]	57.5–59.0 dBA	53.5 dBA
Operating Pressure	1 bar	2.5 bar
Materials (contact with filtrate possible)	Aluminum, CR (Neoprene), NBR (Perbunan)	PPS, EPDM, FPM (Viton)
Connectors for Tube (mm)	ID 9	ID 4
Ambient Temperature	5...40°C	5...40°C
Mains	115 V 60 Hz	115 V 60 Hz
Motor Protection	IP 44	IP 20
Power P1	130 W	65 W
Operating Current	0.9 A	0.63 A
Weight	7.1 kg	1.9 kg
Dimensions W H D (mm)	261 204 110	164 141 90
Recommended application	All multi-branch manifolds	Single filtration run up to 3-branch manifolds

Order numbers

Description	Sartorius Stedim Order No.	Fisher Scientific Order No.
Microsart® maxi.vac for multiple filtration runs, 115 V, 60 Hz	16694-1-60-22	14-555-788
Microsart® mini.vac up to 3 filter stations in parallel, 115 V, 60 Hz	16694-1-60-06	14-555-787

Replacement parts

Replacement kit for 16694-1-60-22 14-555-788, set of one membrane, two valve springs and two head seals	1ED---0055	TBD
Replacement kit for 16694-1-60-06 14-555-787, set of one membrane, two valve springs and two head seals	1ED---0054	TBD
Sound absorber for 16694-1-60-22 14-555-788	1EH---0002	14-555-916
Sound absorber for 16694-1-60-06 14-555-787	1EH---0001	TBD
Fine adjustment head for 16694-1-60-22 14-555-788	1EV---0002	TBD
Fine adjustment head for 16694-1-60-06 14-555-787	1EV---0001	TBD
Fine adjustment head for 16694-1-60-06 14-555-787, for pressure filtration	1EV---0003	TBD



Microsart® e.jet Transfer Pump with Quick Connection

The Microsart® e.jet is a new vacuum laboratory pump able to create sufficient vacuum for vacuum filtration and concomitantly transferring the filtered liquid directly to waste. The second generation of Microsart® e.jet is ideal for sample preparation in Microbiology achieving a trans membrane pressure of 600 mbar and a higher flow rate of > 4.0 NI/min (4.0 Normliters water displacement by air in one minute). Constant flow rates and a defined maximum vacuum guarantee smooth and reliable filtration.



Reducing operating complexity

Until now vacuum equipment for the Membrane Filtration Method consists of numerous parts including connectors, tubes, vacuum containers, protection filter, Woulff's bottle and a vacuum pump. After several samples the vacuum must be broken to empty the filtrate collection container. The complete traditional equipment requires far more laboratory space and is time consuming to operate and maintain. Microsart® e.jet will eliminate the need for side-arm flasks or Woulff's bottles from the laboratory filtration bench.



The Microsart® e.jet pump is an ideal accessory for manifolds up to 3 filter stations. Compared to traditional equipment Microsart® e.jet and a stainless steel manifold require only 30% of the average space meaning in particular less congestion working in Laminar Flow Cabinets.

Traditional vacuum pumps often lose their efficiency and capability to generate sufficient vacuum, when liquid is drawn into the pump head. The Microsart® e.jet is designed to pump both gas and liquids, meaning no loss of efficiency or malfunctions from water drawn into the pump head.

Quick Connection

Building-up the vacuum filtration system is easy and fast thanks to the innovative Quick Connections. The Microsart® e.jet Transfer Pump is equipped with Quick Connection Nipples assembled to Quick Connection Couplings on hose nipples for DN 10 tubings. Simply push-to-connect for assembling and pull-to-disassembling the whole system within seconds. The Quick Connections are non-shut-off.

Some of the advantages you will benefit from when using the Microsart® e.jet

- Ideal for microbiology applications
- No need of suction flasks and water traps
- Saving 70% of work space while saving money – that's economic efficiency

Technical Specifications

Flow rate	> 4.0 NI/min
Max. Vacuum	0.4 bar
Max. Pressure	1.0 bar
Mains	100–240 V 50–60 Hz
Materials (in contact with filtrate)	PTFE, ETFE, Polypropylene, EPDM, POM, PSU
Weight	Pump: 1425.3 g Power supply: 202.8 g
Dimensions (W L H)	120 × 170 × 190 mm
Max. ambient Temp.	+5... +40°C
Max. Temp of liquid	+5... +80°C
Max. viscosity	< 150 cSt
Protection type	IP 64
Protection class	III
Inlet Outlet	Quick Connection on hose nipples for DN 10 tubings

Microsart® e.jet with Quick Connection

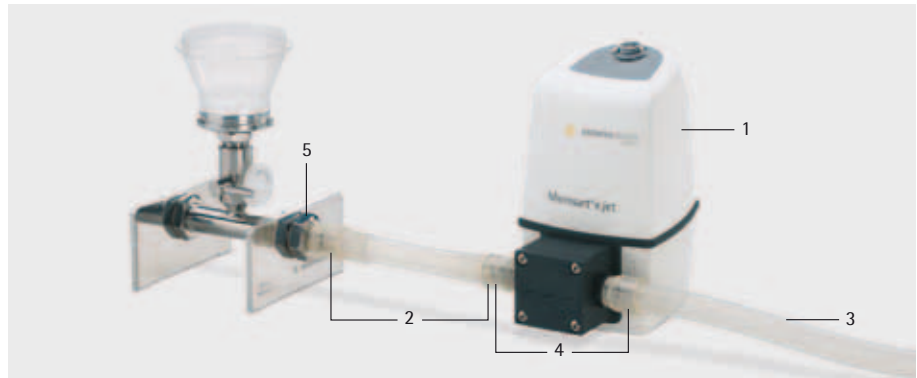

Order Information

Description	Sartorius Stedim Order No.	Fisher Scientific Order No.	No. in picture
Microsart® e.jet Transfer Pump with Quick Connection, without tubings, inlet and outlet hose nipples for DN 10 tubings	166MP-4	TBD	1

Accessories	Sartorius Stedim Order No.	Fisher Scientific Order No.	No. in picture
Tubing with Quick Connection Coupling (PSU), silicone, 20 cm, for vacuum-sided connection, inner diameter DN 10, outer diameter DN 20, wall thickness 5 mm (when ordering, please state length required in meters)	1ZA---0006	TBD	2
Silicone tubing, 1 m, for pressure-sided connection, inner diameter DN 10, outer diameter DN 14, wall thickness 2 mm	1ZAS--0007	TBD	3

Replacement Parts

Description	Sartorius Stedim Order No.	Fisher Scientific Order No.	No. in picture
Pump head complete for 166MP-3 14-555-786 and 166MP-4 TBD	1EP---0001	TBD	
Power supply complete for 166MP-3 14-555-786 and 166MP-4 TBD	1EE---0007	TBD	

Threaded fittings

Description	Sartorius Stedim Order No.	Fisher Scientific Order No.	No. in picture
Quick Connection set, 2 Nipples (POM) on R3/8" male thread and 2 Couplings (PSU) on DN 10 hose nipple	1EAS--0027	TBD	4
Quick Connection Nipple, stainless steel	1EAS--0026	TBD	5
DN 10 hose nipple on R3/8" male thread	1EAF--0020	TBD	



Order numbers traditional pumps

Description	Sartorius Stedim Order No.	Fisher Scientific Order No.
Multiple filtration runs: 13 mbar final vacuum, 26 l/min max., 220 V, 50 Hz	16612	14-555-895
Multiple filtration runs: 13 mbar final vacuum, 26 l/min max., 110 V, 60 Hz	16615	14-555-896
Individual filtration run: 100 mbar final vacuum, 20 l/min max., 220 V, 50 Hz	16692	14-555-902
Individual filtration run: 100 mbar final vacuum, 20 l/min max., 110 V, 60 Hz	16695	14-555-903



Replacement parts

Set of two neoprene membranes, four valve springs and two neoprene head seals for 16612/16615 14-555-895/14-555-896	6986017	14-555-958
Set of one neoprene membrane, two valve springs and one neoprene head seal for 16692/16695 14-555-902/14-555-903	6986105	TBD



Water jet pump

Simple vacuum source. For connection to a water tap with G3/4 male thread.

Description	Sartorius Stedim Order No.	Fisher Scientific Order No.
Water jet pump, with G 3/4 female thread	16611	14-555-894



Hand-operated vacuum pump

Practical vacuum source, also outside of a laboratory. Up to 80% vacuum can be obtained. The body is of PVC. Supplied completely with gauge, vacuum release lever and a 60-cm length of clear plastic tubing.

Description	Sartorius Stedim Order No.	Fisher Scientific Order No.
Hand-operated vacuum pump with gauge	16673	14-555-551



Dosing Syringe

The most convenient way to moisten the NPS with water is to use a dosing syringe with an adapted Minisart® syringe filter. Simultaneous sterilization and dispensing of demineralized water in 3.5 ml steps is easily done by dropping the sinker at the end of the suction tubing into the water, then filling the dosing syringe and dispensing sterile water by operating the trigger automatically.

Description	Sartorius Stedim Order No.	Fisher Scientific Order No.
Dosing syringe, 0.5–5 ml	16685-----2	14-555-901
Minisart®, 0.2 µm, individually, sterile-packaged	17597-----K	14-555-306
Replacement part: tubing with sinker for 16685-----2 14-555-901 and 16685 TBD	6986125	14-555-960
Service Kit for Dosing Syringe 16685-----2 14-555-901	1EP---0002	TBD



Colony counter

Compact, handy battery-operated colony counter, it is as simple to use as a ball-point pen, and has a 4-digit LCD-display. The counter is supplied with an additional marker refill.

Description	Sartorius Stedim Order No.	Fisher Scientific Order No.
Colony counter	17649	14-555-825
Replacement part: Black marker refill	6981540	14-555-955



Stainless steel tweezers

Membrane filters should only be handled with suitable tweezers to avoid contamination which can result from hand contact. Sartorius Stedim Biotech stainless steel tweezers can be flamed and they are autoclavable. They have blunt-edged tips for a careful, firm hold of the membrane filter.

Description	Sartorius Stedim Order No.	Fisher Scientific Order No.
Stainless steel tweezers	16625	14-555-897



Stainless steel prefilter attachment

The stainless steel prefilter holder allows the removal of coarse, solid particles from samples for microbiological analysis before and during the actual bacteria retentive filtration. The device is clipped between funnel and base of the stainless steel vacuum filter holders. It can be autoclaved and flamed. 11301, a white cellulose nitrate (cellulose ester) membrane filter with a pore size of 8 µm is used as the prefilter and it retains the coarse suspended particles from the sample, whereas it allows microorganisms to pass through. These microbes are trapped on the surface of the underlying bacteria-retentive membrane filter (e. g. 0.45 µm). After filtration is complete, the test filter is incubated, and the colonies can grow on the filter surface without disturbance from, or being hidden by, an excess of particles.

Description	Sartorius Stedim Order No.	Fisher Scientific Order No.
Stainless steel prefilter attachment	16807	14-555-907
Cellulose nitrate membranes with 50 mm diameter and 8 µm pore size for the prefilter holder, pack of 100, individually, sterile packaged	11301--50----ACN	14-555-569
Replacement part: support plate, autoclavable, flammable	6981139	TBD



Container for anaerobic incubation

Stainless steel container with 11.8 cm inner diameter, 10.7 cm depth and a with metal insert for convenient insertion and removal of petri dishes. The plastic lid holds two taps for the vacuum exhaust and for cleaning with inert gas, with 6 mm hose nipples (for Sartorius Stedim Order No. 16623 | Fisher Scientific Order No. 14-555-549), vacuum gauge and sealing ring. For up to fourteen 60 mm, or up to six 90 mm petri dishes.

Description	Sartorius Stedim Order No.	Fisher Scientific Order No.
Anaerobic container	16671	TBD

School Kit for Microbiological Experiments



Complete kit

For specific applications in microbiological testing, we recommend our practical, complete kit.

The school kit for microbiological experiments is an ideal teaching aid for instruction in microbiology and environmental protection in schools and other educational institutes. The rugged aluminum case contains all the equipment necessary for microbiological testing.

The handbook included in the case provides general instructions and detailed descriptions of methods for 7 experiments: detection of microorganisms in water, air, and soil; the effects of antibiotics; detection of yeasts on substrates in nature; production of gas through alcoholic fermentation; and bacterial growth at different temperatures.

The vacuum, which is necessary for the filtration, is created with help of a syringe and a 3-way valve.

Contents

Parts supplied	Sartorius Stedim Order No.	Fisher Scientific Order No.
Aluminum case		
Stainless steel tweezers	16625	14-555-897
Filtration system for samples		
Device	16510	14-555-804
3-way valve	16639	14-555-550
Adapter	17108D	TBD
Syringe	16647	TBD
Glass fiber filter	13400-013S	TBD
Filtration system for sterile water		
Filter holder	16517-----E	14-555-557
Syringe	16647	TBD
Membrane filter	11307-025N	TBD
Inoculation loop	17109	14-555-824
Culture media (nutrient broth)	14132-----K	TBD
Wort nutrient pad sets	14058	TBD
Standard nutrient pad sets	14055	TBD
Endo nutrient pad sets	14053	TBD
	Sartorius Stedim Order No.	Fisher Scientific Order No.
School kit for microbiological experiments, in a lockable aluminum case	24002	14-555-917

Sterility Testing Systems

Sterisart® Universal Pump



International pharmacopeias require the complete sterility of pharmaceutical products that are injected into the blood stream or that otherwise enter the body below the skin surface. As a manufacturer of such products, you are required to supply proof of sterility of the final product batch.

The new Sterisart® Universal Pump is available in two versions: as basic version Sartorius Stedim Order No. 16419 | Fisher Scientific Order No. 14-555-826 and as an upgraded version Sartorius Stedim Order No. 16420 | Fisher Scientific Order No. 14-555-827 with display and user software. The pump can be used in clean rooms, integrated into clean benches, or installed countersunk in the working surface of isolators. Its low, compact

design has a space-saving footprint – a great benefit for most clean room benchtops and isolators.

Additional Features and Benefits

- Closed system – no ventilation for enhanced safety
- Robust and maintenance free
- Compact and ergonomic construction
- Modular design
- Pump available with special software (operator-guided menus; all process sequences can be logged; barcode recognition)

Special brochures available on request.
Order no. SLD1003-e, SLD2010

Specifications

Technical specifications for Sterisart® Universal pump

Pump flow rate	70–650 ml/min
Power requirements	100–240 VAC
Frequency	50–60 Hz
Power consumption	100 W
Dimensions	
Pump	approx. 336×260×210 mm (with lever) (W×D×H)
Pump with holding ring for bottles, container	approx. 440×365×485 mm (W×D×H)
Weight	
Basic version 16419 14-555-826	approx. 13.5 kg
Upgraded version 16420 14-555-827 with display and user software	approx. 14.6 kg

Ordering Information

Sartorius Stedim Order No.	Fisher Scientific Order No.	Description
16419	14-555-826	Sterisart® Universal pump, basic version
16420	14-555-827	Sterisart® Universal pump, upgraded version with display user software

Accessories

Sartorius Stedim Order No.	Fisher Scientific Order No.	Description
1ZE---0033	TBD	Footswitch
1ZG---0014	14-555-862	Adapter for Sterisart® NF units, fitting into container for draining of Millipore Equinox pump
1ZG---0025	TBD	Adapter for Sterisart® NF units, fitting into container for draining (with two slightly different diameters of the fixation-slots) of new Millipore Equinox pump
1ZE---0039	14-555-856	Transport trolley
1ZE---0040	TBD	Communication kit
1ZE---0050	TBD	Installation kit for isolators

Further accessories are available on request.

Sterility Testing Systems Sterisart® NF



Sterisart® NF is a completely closed system for the sterility testing of pharmaceutical products. It is based on the membrane filter method, however it eliminates the procedure of manipulating the filters. By this the main risk of a secondary contamination and false positive results is eliminated. A peristaltic pump transfers the sample into the filtration units, and after rinsing, the filtration units are filled with media and used for incubation of the filters without any contact to the environment.



Special brochures available on request.
Order no. SLD1002-e, SL-2019-e,
SLD2006-e, SLD2005-e, SLD2007-e,
S--2019-e, SLD2009-e, SLD2011-e

Sterisart® NF offers the following features and benefits

- Reliable, Sartochem® membrane:
 - High retention of microbes
 - Low adsorption
 - High mechanical stability
- Easy to use:
 - Pre-installed color-coded tube clamps
 - Easy-to-read graduated marks
 - User-friendly, several practical adapters available
 - Product- | lot number identification
- Secure:
 - Gas-impermeable packaging for protection against sterilants

Specifications

Technical specifications for Sterisart® NF

Pore size of the Sartochem® membrane filter	0.45 µm, tested with Serratia marcescens
Filter area	15.7 cm ² in each Sterisart® container
Flow rate (for water)	500 ml/min at 1 bar (approx. 15 psi)
Pore size of the air filters	0.2 µm PTFE, validated acc. to HIMA for the retention of B. diminuta
Sample container capacity	120 ml (graduation marks at 50, 75 and 100 ml)
Max. operating pressure	3 bar (approx. 44 psi) at 20°C
Max. operating temperature	50°C
Sterilization	ETO (ethylene oxid gas) or gamma irradiation

Ordering Information

Sterisart® NF alpha disposable units for sterility testing in clean rooms, individually, sterile packaged, ETO-sterilized, needles made of flammable stainless steel, pack size 10

Type of sample	Type of sample container	Description	Sartorius Stedim Order No.	Fisher Scientific Order No.
LVPs	Closed glass bottles with septum	Sterisart® NF alpha with long dual-needle spike, sterile vented	16466-----ACD	14-555-828
LVPs SVPs	Open containers (i.e. glass ampoules, glass bottles), collapsible bags	Sterisart® NF alpha with long needle, inclusive sterile venting needle	16467-----ACD	14-555-832
Medical devices	Tubing systems and bags with Luer or Luer Lock connectors	Sterisart® NF alpha with Luer or Luer Lock connection, inclusive long needle and sterile venting needle	16468-----ACD	TBD

Sterisart® NF gamma disposable units for sterility testing in isolators, individually sterile, double-packaged, gamma irradiated, needles made of flammable stainless steel, pack size 10

Type of sample	Type of sample container	Description	Sartorius Stedim Order No.	Fisher Scientific Order No.
LVPs	Closed glass bottles with septum	Sterisart® NF gamma with long dual-needle spike, sterile vented	16466-----GBD	14-555-829
SVPs	Closed glass vials with septum	Sterisart® NF gamma with short dual-needle spike, sterile vented	16476-----GBD	14-555-839
LVPs, SVPs, eye drops	Closed plastic containers vials ampoules, plastic containers of Blow-Fill-Seal fillings	Sterisart® NF gamma with long needle, side opening, with solid pointed tip, non-coring, inclusive sterile venting needle	16477-----GBD	14-555-840
LVPs SVPs	Open containers (i.e. glass ampoules, glass bottles), collapsible bags	Sterisart® NF gamma with long needle, inclusive sterile venting needle	16467-----GBD	14-555-833
Lyophilisates, soluble powders, liquid antibiotics	Closed glass vials with septum	Sterisart® NF gamma with two dual-needle spikes of different length, one is sterile vented	16475-----GBD	14-555-838
Pre-filled syringes	Syringes with and without needles	Sterisart® NF gamma with syringe-adapter and long dual-needle spike, sterile vented	16469-----GBD	14-555-835
Medical devices	Tubing systems and bags with Luer or Luer Lock connectors	Sterisart® NF gamma with Luer or Luer Lock connection, inclusive long needle and sterile venting needle	16468-----GBD	14-555-834
NEW Medical devices	Containers bags with Luer Lock male connectors	Sterisart® NF gamma with female Luer Lock connection	16478-----GBD	14-555-841

Sterisart® NF gamma Septum, disposable units for sterility testing in isolators, Sterisart® NF containers with integrated septum for reliable sterile sample taking individually sterile, double-packaged, gamma irradiated, needles made of flammable stainless steel, pack size 10

Type of sample	Type of sample container	Description	Sartorius Stedim Order No.	Fisher Scientific Order No.
LVPs	Closed glass bottles with septum	Sterisart® NF gamma Septum with long dual-needle spike, sterile vented	16466-----GSD	14-555-830
LVPs SVPs	Open containers (i.e. glass ampoules, glass bottles), collapsible bags	Sterisart® NF gamma Septum with long needle, inclusive sterile venting needle	16467-----GSD	TBD
Lyophilisates, Soluble powders, Liquid antibiotics	Closed glass vials with septum	Sterisart® NF gamma Septum with two dual-needle spikes of different length, one is sterile vented	16475-----GSD	TBD
Pre-filled syringes	Syringes with and without needles	Sterisart® NF gamma Septum with syringe-adapter and long dual-needle spike, sterile vented	16469-----GSD	TBD

Accessories

Application	Description	Sartorius Stedim Order No.	Fisher Scientific Order No.
Difficult-to-dissolve powders in closed glass vials with septum, non-vacuo	Sterisart® NF gamma tubing system with two dual-needle spikes of different length, needles made of flammable stainless steel	16470-----GBD	14-555-836
Sterile venting of containers with rinsing solution and nutrient media, additional sterile venting needles, equal to the inclusive needles of the Sterisart® NF units i.e. type 16467, 16468 and 16477	Needle with venting filter, 4 cm, stainless steel, individually sterile packaged, gamma irradiated, pack size 50	16596-----HNK	TBD

Further units (Sartorius Stedim Order No. 16464-----ACD | GBD | Fisher Scientific Order No. TBD) on request.

Reusable Sterility Test System



Reusable sterility test system for the sterility testing of injection and infusion solutions. The filter holders are easy to clean, dishwasher safe and autoclavable.

The system can be designed according to the needs of the user, and the membrane filter can be chosen according to requirements.

Specifications of the filter holders

Material	Glass cylinder; polypropylene base and sealing plug; anodized aluminum closing cap.
Sealing	Silicone gasket, 36/47 mm (Sartorius Stedim Order No. 6980573 Fisher Scientific Order No. 14-555-940) Silicone O-ring, 40.5x 3.5 mm (Sartorius Stedim Order No. 6980574 Fisher Scientific Order No. 14-555-941)
Filter diameter	47 mm
Filtration area	12.5 cm ²
Capacity	16523 14-555-806: 130 ml (56 ml up to the mark for aerobic incubation at a level of 60 mm, 110 ml up to the mark at the 115-mm level).
Operating pressure	Vacuum only
Sterilization	Autoclaving at 121°C

General accessories for the reusable sterility test system

Description	Sartorius Stedim Order No.	Fisher Scientific Order No.
Filter holder with 130 ml capacity	16523	14-555-806
Stainless steel manifold	16826	14-555-792
Stainless-steel adapter	17756	14-555-914
T-distributor for 2 filter holders	16966	14-555-846
Filling cap with filling needle	16967	14-555-847
Silicone adapter	16968	14-555-848
Peristaltic pump	16696	14-555-904
Silicone tubing, 4 x 1.5 mm	16699	14-555-905
Holding rod for inlet tube needle	16974	14-555-851
Incubation rack	16975	14-555-852
Tube clamps (tubing clips)	16978	14-555-853
Venting filters, pack size 50	17574-----K	14-555-294

Additional accessories for reusable sterility test system (for ampoule testing)

Inlet tube	16963	14-555-843
Holding tongs	16973	14-555-850
Ampoule breaker	16969	14-555-849
Clamp holder	16976	TBD
Support stand	16970	TBD

Additional accessories for reusable sterility testing system (for testing infusion solutions in bottles)

Inlet needle (long)	16964	14-555-844
Inlet needle (short)	16964-----3	14-555-845

**Consumables (membrane filters, 47 mm, 100 pieces/pack)
for the reusable sterility test system**

Sartorius Stedim Order No.	Fisher Scientific Order No.	Pore size	Description	Application
11306--47-----N	14-555-401	0.45 µm	Cellulose nitrate membrane filter	pH 4-8, most hydrocarbons
13106--47----HCN	TBD	0.45 µm	Cellulose nitrate membrane filter with hydrophobic edge	pH 4-8, most hydrocarbons
11106--47-----N	14-555-362	0.45 µm	Cellulose acetate membrane filter	pH 4-8, most alcohols, hydrocarbons and oils
13506--47----HCN	TBD	0.45 µm	Cellulose acetate membrane filter with hydrophobic edge	pH 4-8, most alcohols, hydrocarbons and oils
18406--47-----N	14-555-465	0.45 µm	Regenerated cellulose membrane filter	pH 3-12, solvent-resistant
11407--47-----N	14-555-607	0.2 µm	Cellulose nitrate membrane filter	pH 4-8, most hydrocarbons
13107--47----HCN	TBD	0.2 µm	Cellulose nitrate membrane filter with hydrophobic edge	pH 4-8, most hydrocarbons
11107--47-----N	14-555-369	0.2 µm	Cellulose acetate membrane filter	pH 4-8, most alcohols, hydrocarbons and oils
13507--47----HCN	TBD	0.2 µm	Cellulose acetate membrane filter with hydrophobic edge	pH 4-8, most alcohols, hydrocarbons and oils
18407--47-----N	14-555-469	0.2 µm	Regenerated cellulose membrane filter	pH 3-12, solvent-resistant



Peristaltic pump

Specifications

Rotor speed	1.5–220 rpm
Operating voltages and frequencies	110–240 V 50/60 Hz
Speed control ratio	147:1
Power rating	100 VA
Operating temperature	4°C to 40°C
Storage temperature range	–40°C to 70°C
Weight	5.5 kg 12.1 lbs
Noise	<70 dBA at 1 m
Standards	IEC 335-1, EN 60529 (IP31)
Machinery Directive	98/37/EG EN 60204-1
Low Voltage Directive	73/23/EG EN 61010-1
EMC Directive	89/336/EG EN 50081-1/EN 50082-1

Sartorius Stedim Order No.	Fisher Scientific Order No.
16696	14-555-904

CONFIDENCE® Validation Services



Sterility testing is a critical step in pharmaceutical product release. It is a very exacting procedure where aseptic conditions, well trained personnel and validated methods must be adhered in order to achieve reliable interpretation of the results. Validation of the sterility test is essential for the quality management in order to meet regulatory requirements.

Regulatory Compliance

CONFIDENCE® provides the closest interpretation of current regulatory requirements and industry standards. We are working with you to define relevant test conditions for your sample preparation based on your actual product formulation.



The validation of the sterility testing procedure is conducted in certified and FDA registered laboratories. cGMP recommendations are applied for the testing procedures.

Validation of the Sterility Testing Procedure

Chemical compatibility study

Demonstration of the chemical resistance of all Sterisart® NF plastic parts (needles, connections, tubing and containers) to the product sample. In addition the filter integrity of the Sartochem® membrane is determined.

Growth promotion

Microbial growth should not be inhibited by the product sample. This "positive control" is conducted under routine testing conditions and controlled environment.

Sterility test

Performance of the sterility test of the product sample according to international pharmacopoeia.

Documentation

Detailed protocols and reports including rationale, test results and method transfer assessment are provided. They are in line with the health authority requirements. Full traceability is available according to cGMP recommendations and internal quality systems.

EXPAND® Trainings and Seminars



We think in processes.
It is possible to add value only if products and services are effectively intermeshed. As a capable service partner, Sartorius Stedim Biotech offers you a truly comprehensive spectrum of services. These are not only offered in conjunction with Sartorius Stedim Biotech projects, but also are available for other manufacturers' equipment and independently of products.

These training seminar are intended for staff members working in the areas of quality assurance and/or quality control in the pharmaceutical industry and food and beverage industry.



Microbiological Basics of Product Safety and Industrial Hygiene

Theoretical Aspects

- Introduction to general microbiology
- Growth conditions | microbiological detection methods
- The microbiological lab
- Microbiological examination of water and drinking water: regulations und methods
- Personnel hygiene

Practical Exercises

- Introduction to microbiological work
- Pour plate, streak plate
- Sample filtration runs with various media: water, particulate media, oil-containing samples
- Evaluation of different growth samples



Advanced Course for Beverage Industries

Theoretical Aspects

- Product-spoiling microorganisms | detection methods
- Biochemical differentiation
- Hazard Analysis and Critical Control Points Concept (HACCP)
- Industrial Hygiene

Practical Exercises

- Microscopic examination of bacteria, yeast and molds
- Differentiation of bacteria and yeast:
 - Morphologic and microscopic examination
 - Gram-staining (alternative methods)
 - Biochemical tests
 - Use of different identification systems

Use of Light Microscopy in Microbiological Quality Control

Theoretical Aspects

- Basic principles of microscopy
- Optical train | Köhler illumination
- Bright field | dark field | phase contrast
- Fluorescence microscopy | applications in microbiological QC
- Determination of the cellular morphology of bacteria and fungi using light microscopy

Practical Exercises

- Adjusting the microscope | Köhler illumination
- Microscopic examination of prepared sample with bright field | dark field | phase contrast
- Microscopic examination of bacteria, yeast and molds

Workshop on Sterility Testing

Theoretical Aspects

- Sterility testing
 - Regulations and guidance
 - Sterility test methods | Test limitations
 - Interpretation of sterility test results
 - Validation
- Sterility test isolators
 - Standards and regulation | Design
 - H₂O₂ decontamination
 - Microbiological monitoring

Practical Exercises

- Sterility testing of different products (LVPs | SVPs | ampoules | antibiotics | medical devices)
- Performing sterility test in isolators
- Observation and interpretation of results
- Sterility test isolators in routine

Registration and Information

Dr. Dagmar Simons
EXPAND® Trainings and Seminars

Sartorius Stedim Biotech GmbH
Training Center
August-Spindler-Strasse 11
37079 Goettingen, Germany

Phone +49.551.308.1227
Fax +49.551.308.1293

dagmar.simons@sartorius-stedim.com

Chemical Compatibility

1. Filter Materials and Mini Cartridges

	Cellulose acetate	Cellulose nitrate	Reg. Cellulose	PTFE	Polyamide	Glass fiber	Polycarbonate	Polyether-sulfone	Sartobran® P cartridge	Sartofluor® cartridge
Solvents	111	113	184	118	250	134	230	154		
Acetone	-	-	•	•	-	•	○	-	-	E
Acetonitrile	?	?	•	•	-	?	?	•	?	?
Gasoline	•	•	•	•	•	•	•	•	V	-
Benzene	•	•	•	•	•	•	?	•	-	-
Benzyl alcohol	○	○	•	•	•	•	?	-	○	•
n-Butyl acetate	○	-	•	•	•	•	•	•	E	?
n-Butanol	•	•	•	•	•	•	•	•	•	•
Cellosolve	•	-	•	•	?	•	-	•	-	-
Chloroform	-	•	•	•	•	•	-	-	-	-
Cyclohexane	○	○	•	•	?	•	•	-	○	V
Cyclohexanone	-	-	•	•	•	•	?	?	-	-
Diethylacetamide	-	-	•	•	•	•	?	?	-	?
Diethyl ether	•	-	•	•	•	•	•	?	-	-
Dimethyl formamide	-	-	○	•	○	•	-	?	-	•
Dimethylsulfoxide	-	-	•	•	•	•	-	-	-	•
Dioxane	-	-	•	•	•	•	-	•	-	•
Ethanol, 98%	•	○	•	•	•	•	•	•	•	•
Ethyl acetate	-	-	•	•	•	•	?	-	-	-
Ethylene glycol	•	○	•	•	?	•	•	•	•	•
Formamide	?	?	?	•	?	•	-	?	-	•
Glycerine	•	•	•	•	•	•	•	•	•	•
n-Heptane	•	•	•	•	?	•	?	?	•	V
n-Hexane	•	•	•	•	•	•	•	?	V	-
Isobutanol	○	○	•	•	•	•	•	?	-	•
Isopropanol	•	○	•	•	•	•	•	•	•	•
Isopropyl acetate	○	-	•	•	?	•	?	•	-	•
Methanol, 98%	•	-	•	•	?	•	•	•	•	•
Methyl acetate	-	-	•	•	•	•	?	-	-	•
Methylene chloride	-	○	•	•	•	•	-	-	-	-
Methyl ethyl ketone	-	-	•	•	•	•	?	-	-	•
Methyl isobutyl ketone	•	-	•	•	•	•	?	?	-	-
Monochlorobenzene	•	•	•	•	•	•	-	?	V	V
Nitrobenzene	•	○	•	•	•	•	-	?	-	-
n-Pentane	•	•	•	•	•	•	•	?	V	V
Perchloroethylene	•	•	•	•	•	•	•	?	V	V
Pyridine	-	-	•	•	•	•	-	-	-	-
Carbon tetrachloride	○	•	•	•	•	•	?	•	-	?
Tetrahydrofuran	-	-	•	•	•	•	-	-	-	-
Toluene	•	•	•	•	•	•	?	•	-	-

Key to symbols see next page.

	Cellulose acetate	Cellulose nitrate	Reg. Cellulose	PTFE	Polyamide	Glass fiber	Polycarbonate	Polyether-sulfone	Sartobran® P cartridge	Sartofluor® cartridge
Solvents	111	113	184	118	250	134	230	154		
Trichloroethane	○	●	●	●	?	●	?	?	–	?
Trichloroethylene	●	●	●	●	●	●	–	●	–	?
Xylene	●	●	●	●	●	●	●	●	–	–
Acids										
Acetic acid, 25%	●	●	●	●	○	?	○	●	●	?
Acetic acid, 96%	–	–	●	●	–	?	?	●	–	●
Hydrofluoric acid, 25%	●	○	○	●	–	?	●	?	–	–
Hydrofluoric acid, 50%	●	○	–	●	–	?	●	?	–	–
Perchloric acid, 25%	–	○	○	●	–	?	?	?	–	●
Phosphoric acid, 25%	●	○	○	●	–	?	?	?	●	●
Phosphoric acid, 85%	○	○	○	●	–	?	–	?	–	V/E
Nitric acid, 25%	–	○	–	●	–	?	●	●	–	V
Nitric acid, 65%	–	–	–	●	–	?	●	●	–	–
Hydrochloric acid, 25%	–	○	–	●	–	?	●	●	–	V/E
Hydrochloric acid, 37%	–	–	–	●	–	?	●	●	–	V/E
Sulfuric acid, 25%	–	○	○	●	–	●	?	●	–	●
Sulfuric acid, 98%	–	–	–	●	–	?	–	?	–	–
Trichloroacetic acid, 25%	–	○	●	●	–	?	?	?	–	●
Bases										
Ammonium, 1N	●	●	○	●	●	●	–	●	E	●
Ammonium hydroxide, 25%	–	○	–	○	●	○	–	●	–	●
Potassium hydroxide, 32%	–	–	○	●	○	○	–	●	–	●
Sodium hydroxide, 32%	–	–	○	●	○	○	–	●	–	●
Sodium, 1N	○	–	○	●	●	●	–	●	–	●
Aqueous solutions										
Formaline, 30%	○	●	○	●	○	●	●	●	–	●
Sodium hypochlorite, 5%	●	○	●	●	○	●	?	?	–	●
Hydrogen peroxide, 35%	●	●	○	●	○	?	?	?	●	●

Key to symbols

- = compatible
- = limited compatibility
- = not compatible
- ? = not tested

E = compatible after replacing silicone O-ring with an EPDM O-ring

V = compatible after replacing the silicone O-ring with a Viton O-ring

Contact time: 24 hours at 20°C

Chemical compatibilities can be influenced by various factors.

Therefore, we recommend that you confirm compatibility with the liquid you wish to filter by performing a trial filtration run before you begin with actual filtration.

2. Filter Holder, Cartridge Housing and O-ring Materials

	Glass	Poly-carbonate	Poly-propylene	PTFE	Stainless steel	EPDM O-ring	PTFE O-ring	Silicone O-ring	Viton O-ring
Solvents									
Acetone	•	○	•	•	•	•	•	–	–
Acetonitrile	•	?	•	•	•	○	•	–	•
Gasoline	•	○	•	•	•	–	•	–	•
Benzene	•	–	–	•	•	–	•	–	•
Benzyl alcohol	•	–	•	•	•	○	•	•	•
n-Butyl acetate	•	–	○	•	•	•	•	–	–
n-Butanol	•	•	•	•	•	•	•	•	•
Cellosolve	•	–	–	•	•	○	•	–	–
Chloroform	•	–	–	•	•	–	•	–	•
Cyclohexane	•	○	•	•	•	–	•	–	•
Cyclohexanone	•	–	•	•	•	–	•	–	–
Diethylacetamide	•	–	?	•	•	?	•	•	–
Diethyl ether	•	–	○	•	•	–	•	–	–
Dimethyl formamide	•	–	•	•	•	•	•	○	–
Dimethylsulfoxide	•	?	?	•	•	?	•	○	–
Dioxane	•	–	○	•	•	•	•	–	–
Ethanol, 98%	•	•	•	•	•	•	•	•	•
Ethyl acetate	•	–	•	•	•	•	•	–	–
Ethylene glycol	•	•	•	•	•	•	•	•	•
Formamide	•	–	•	•	•	•	•	–	○
Glycerine	•	○	•	•	•	•	•	•	•
n-Heptane	•	•	•	•	•	–	•	•	•
n-Hexane	•	•	•	•	•	–	•	–	•
Isobutanol	•	•	•	•	•	•	•	•	•
Isopropanol	•	○	•	•	•	•	•	•	•
Isopropyl acetate	•	•	•	•	•	•	•	–	–
Methanol, 98%	•	–	•	•	•	•	•	•	•
Methyl acetate	•	?	•	•	•	•	•	–	–
Methylene chloride	•	–	–	•	•	–	•	–	○
Methyl ethyl ketone	•	–	•	•	•	•	•	–	–
Methyl isobutyl ketone	•	–	?	•	•	–	•	–	–
Monochlorobenzene	•	–	•	•	•	–	•	–	•
Nitrobenzene	•	–	○	•	•	–	•	–	–
n-Pentane	•	•	•	•	•	–	•	–	•
Perchloroethylene	•	–	○	•	•	–	•	–	•
Pyridine	•	–	○	•	•	–	•	–	–
Carbon tetrachloride	•	–	○	•	•	–	•	–	•
Tetrahydrofuran	•	–	○	•	•	–	•	–	–
Toluene	•	–	•	•	•	–	•	–	○

Key to symbols see next page.

	Glass	Poly-carbonate	Poly-propylene	PTFE	Stainless steel	EPDM O-ring	PTFE O-ring	Silicone O-ring	Viton O-ring
Solvents									
Trichloroethane	•	–	?	•	•	–	•	–	•
Trichloroethylene	•	–	–	•	•	–	•	–	•
Xylene	•	–	○	•	•	–	•	–	○
Acids									
Acetic acid, 25%	•	•	•	•	•	•	•	•	–
Acetic acid, 96%	•	–	•	•	•	•	•	?	–
Hydrofluoric acid, 25%	–	–	•	•	–	○	•	–	○
Hydrofluoric acid, 50%	–	–	•	•	–	○	•	–	○
Perchloric acid, 25%	•	○	•	•	–	•	•	–	•
Phosphoric acid, 25%	•	○	•	•	○	•	•	–	•
Phosphoric acid, 85%	•	○	•	•	○	•	•	–	•
Nitric acid, 25%	•	–	•	•	–	○	•	–	•
Nitric acid, 65%	•	–	–	•	–	–	•	–	•
Hydrochloric acid, 25%	•	○	•	•	–	○	•	–	•
Hydrochloric acid, 37%	•	–	•	•	–	•	•	–	•
Sulfuric acid, 25%	•	•	•	•	○	•	•	–	•
Sulfuric acid, 98%	•	–	–	•	–	–	•	–	•
Trichloroacetic acid, 25%	•	○	•	•	–	•	•	–	–
Bases									
Ammonium, 1N	•	–	•	•	•	•	•	–	–
Ammonium hydroxide, 25%	•	–	•	•	•	•	•	•	–
Potassium hydroxide, 32%	•	–	•	•	•	•	•	○	○
Sodium hydroxide, 32%	•	–	•	•	•	•	•	○	•
Sodium, 1N	•	–	•	•	•	•	•	•	•
Aqueous solutions									
Formaline, 30%	•	•	•	•	•	•	•	○	•
Sodium hypochlorite, 5%	•	•	•	•	•	•	•	•	•
Hydrogen peroxide, 35%	•	•	•	•	•	•	•	•	•

Key to symbols

- = compatible
- = not compatible
- = limited compatibility
- ? = not tested

Contact time: 24 hours at 20°C

Chemical compatibilities can be influenced by various factors. Therefore, we recommend that you confirm compatibility with the liquid you wish to filter by performing a trial filtration run before you begin with actual filtration.

3. Ready-to-Connect Filtration Units

	Midisart® 2000	Minisart®	Minisart® HY	Minisart® RC	Minisart® SRP	Sartobran® 300	Sartobran® P Capsule	Sartofluor® Capsule	Sartolab® P20
Solvents									
Acetone	•	–	–	•	–	–	–	•	–
Acetonitrile	•	–	?	•	•	?	?	?	?
Gasoline	•	•	•	•	•	•	•	•	○
Benzene	•	–	–	?	•	–	–	○	–
Benzyl alcohol	•	?	?	?	•	○	○	•	–
n-Butyl acetate	•	–	–	?	•	•	•	•	–
n-Butanol	•	○	○	•	•	•	•	•	•
Cellosolve	○	–	–	•	○	–	–	○	–
Chloroform	•	–	–	•	•	–	–	•	–
Cyclohexane	•	–	–	?	•	○	○	•	○
Cyclohexanone	•	–	–	?	•	–	–	•	–
Diethylacetamide	•	–	–	•	•	–	–	•	–
Diethyl ether	•	?	?	?	•	○	○	•	–
Dimethyl formamide	•	–	–	?	•	–	–	•	–
Dimethylsulfoxide	•	–	–	•	•	–	–	•	–
Dioxane	•	–	–	•	•	–	–	○	–
Ethanol, 98%	•	–	–	•	•	•	•	•	•
Ethyl acetate	•	○	○	•	•	–	–	○	–
Ethylene glycol	•	?	?	•	•	•	•	•	•
Formamide	•	?	?	?	•	?	?	•	–
Glycerine	•	•	•	?	•	•	•	•	○
n-Heptane	•	•	•	?	•	•	•	•	•
n-Hexane	•	•	•	•	•	•	•	•	•
Isobutanol	•	○	○	•	•	○	○	•	○
Isopropanol	•	○	○	–	•	•	•	•	○
Isopropyl acetate	•	○	○	?	•	○	○	•	○
Methanol, 98%	•	–	–	•	•	•	•	•	–
Methyl acetate	•	–	–	?	•	–	–	•	–
Methylene chloride	•	–	–	•	•	–	–	○	–
Methyl ethyl ketone	•	–	–	•	•	–	–	•	–
Methyl isobutyl ketone	•	?	?	?	•	?	?	•	–
Monochlorobenzene	•	?	?	?	•	•	•	•	–
Nitrobenzene	•	?	?	?	•	○	○	•	–
n-Pentane	•	•	•	•	•	•	•	•	•
Perchloroethylene	•	○	○	?	•	○	○	•	–
Pyridine	•	–	–	?	•	–	–	•	–
Carbon tetrachloride	•	○	○	?	•	○	○	•	–
Tetrahydrofuran	•	–	–	•	•	–	–	○	–
Toluene	•	–	–	•	•	•	•	•	–

Key to symbols see next page.

	Midisart® 2000	Minisart®	Minisart® HY	Minisart® RC	Minisart® SRP	Sartobran® 300	Sartobran® P Capsule	Sartofluor® Capsule	Sartolab® P20
Solvents									
Trichloroethane	•	○	○	•	•	?	?	•	-
Trichloroethylene	○	?	?	?	○	-	-	-	-
Xylene	•	-	-	•	•	○	○	•	-
Acids									
Acetic acid, 25%	•	○	○	?	?	•	•	•	•
Acetic acid, 96%	•	-	-	?	•	-	-	•	-
Hydrofluoric acid, 25%	•	○	○	?	•	•	•	•	-
Hydrofluoric acid, 50%	•	○	○	?	•	-	-	•	-
Perchloric acid, 25%	•	?	?	?	•	-	-	•	-
Phosphoric acid, 25%	•	•	•	?	•	•	•	•	•
Phosphoric acid, 85%	-	?	?	?	-	○	○	-	○
Nitric acid, 25%	•	-	-	?	•	-	-	•	-
Nitric acid, 65%	•	-	-	?	•	-	-	○	-
Hydrochloric acid, 25%	•	-	-	?	•	-	-	•	-
Hydrochloric acid, 37%	•	-	-	?	•	-	-	•	-
Sulfuric acid, 25%	•	-	-	?	•	-	-	•	-
Sulfuric acid, 98%	•	-	-	?	•	-	-	•	-
Trichloroacetic acid, 25%	•	-	-	•	•	-	-	•	-
Bases									
Ammonium, 1N	•	•	•	?	•	•	•	•	-
Ammonium hydroxide, 25%	•	○	○	?	•	○	○	•	-
Potassium hydroxide, 32%	•	-	-	?	•	-	-	•	-
Sodium hydroxide, 32%	•	-	-	?	•	-	-	•	-
Sodium, 1N	•	○	○	?	•	○	○	•	-
Aqueous solutions									
Formaline, 30%	•	-	-	?	•	○	○	•	○
Sodium hypochlorite, 5%	•	•	•	?	•	-	-	•	•
Hydrogen peroxide, 35%	•	•	•	?	•	•	•	•	•

Key to symbols

- = compatible
- = limited compatibility
- = not compatible
- ? = not tested

Contact time: 24 hours at 20°C

Chemical compatibilities can be influenced by various factors. Therefore, we recommend that you confirm compatibility with the liquid you wish to filter by performing a trial filtration run before you begin with actual filtration.

Index

Absorbent Pads	28	Manifolds, multi-branch	47
Accessories for vacuum filter holders and manifold systems	50	MD8 airscan®	6, 8, 10
Airborne bacteria and viruses	5, 10	MD8 calibration unit	10
Air Monitoring	6	MD8 devices	10
AirPort MD8	7, 10	Media	24
Air Sampler	6, 9	Membranes without grid	20
Aluminum stack	10	Microsart® Combi.jet	42
		Microsart® e.jet	46, 53, 54
		Microsart® e.motion	14, 27
BACTair™	9	Microsart® e.motion Dispenser	14
Biosart® 100 Monitor	30	Microsart® e.motion Membrane Filters	15, 27
Biosart® 100 Nutrient media	32	Microsart® @filter 100 and 250	33
Biosart® 250 Funnel	37	Microsart® @vance®	33
		Microsart® Funnel 100 and 250	35
Calibration unit	10	Microsart® maxi.vac	52
Case for MD8 airscan®	11	Microsart® mini.vac	52
Cellulose acetate	13, 20, 22, 65	Minisart® SRP	41
Cellulose Nitrate (Cellulose Ester)	12, 16, 18, 20, 22, 57	Multi-branch manifolds, traditional	47
Chemical Compatibility	68	NPS	4, 24, 55
Colony counter	56	Nutrient media broth	32
Colony counting	4, 12	Nutrient pad sets in petri dishes	24
Combisart® multi-branch systems	38		
CONFIDENCE® Validation Services	66	Pedal (foot switch) for Microsart® e.motion	14
Container for anaerobic incubation	57	Peristaltic pump	65
Culture media	4, 24, 28	Preassembled Monitors	5, 30
Dispenser	4, 14, 29	Quick connection for tubings	43, 54
Dosing syringe	55		
		Ready-to-use units including media	30
EXPAND® Trainings and Seminars	67	Reusable sterility test system	64
		Rubber vacuum hose	51
Filter dispenser	14		
Filter holders and manifolds	38	Sartochem®	60, 61
Filter holders, individual	47	School kit for microbiological experiments	58
		Single-use funnels	5, 37
Gelatine membrane filters	8	Stainless steel filter holder, 50 mm, with vacuum control	47
Gridded membrane filters for colony counting	12	Stainless steel funnels	5, 38
Gridded membrane filters, type 111	21	Sterility Testing Systems	59
Gridded membrane filters, type 113	21	Sterisart®	5, 59
Gridded membrane filters, type 114	17, 19	Sterisart® NF	60
Gridded membrane filters, type 130	17, 19	Sterisart® Universal Pump	59
Gridded membrane filters, type 131	23	Suction flask, 2 liter capacity	50
Gridded membrane filters, type 135	23		
Gridded membrane filters, type 138	17, 19	Vacusart®	51
Gridded membrane filters, type 139	17, 19	Vacuum filtration system	44
Gridded membranes	12, 16		
		Water jet pump	55
Hand-operated vacuum pump with gauge	55	Water trap, Vacusart®	51
High flow membranes	4, 13	Woulff's bottle	51
Hydrophobic edged membranes	22		
Laboratory pump, 90%	55		
Laboratory pump, 98%	55		

For the purpose of product development we reserve the right to make changes without notice.



For customer service, call 1-800-766-7000.
To fax an order, use 1-800-926-1166.
To order online: www.fishersci.com