



ISO 9001:2008 REGISTERED

**Version**

**8.0**

Corporate Headquarters - 452 Hardy Rd, Brantford ON, Canada N3T 5L8 • T. 519.752.7825 • F. 519.752.2895  
562 Industrial Park Rd, P.O. Box 156, Maxwelton, WV, USA 24957 • T. 304.497.2115  
596 Blue Ridge Ave. Suite 1A, Bedford, VA, USA 24523 • T. 540.425.3665

[www.mott.ca](http://www.mott.ca)



# MOTT MANUFACTURING

Mott Manufacturing provides complete solutions for all your laboratory needs. Serving the industrial, pharmaceutical, education, health care and government markets since the early 1960's. Our goal for our products is simple: make them well, make them on time, and make them affordable. We accomplish this by committing ourselves to two things: state-of-the-art technology and excellent customer service.

## **COMMITMENT TO TECHNOLOGY**

- Each of Mott's manufacturing facilities are outfitted with the highest state-of-the-art tooling technology available. To make your products well, on time, and affordable, the best technology is absolutely necessary.

## **COMMITMENT TO CUSTOMER SERVICE**

- You have access to a broad selection of products in wood, steel, galvanized steel, and stainless steel. These products are built to strict and established standards. Such as UL, SEFA, ASHRAE, ANSI, CSA, AWI, and many others.

- We manufacture the very finest laboratory furniture steel casework • architectural wood casework • core based systems • plug and play workstations • mobile carts and tables • overhead service carriers • fume hoods and much more...

- Each laboratory's needs are unique, we can design and engineer products to meet your exact requirements. We'll accommodate your needs without damage to your schedule or your budget.

- We're committed to the environment. Our steel casework and fume hoods are made from the most recycled material on the planet and is covered with a modern VOC free powder coat paint. Our wood products support sustainability and indoor environmental health, and are protected by a VOC free, rock hard UV flat line finish system. When it comes to fume hoods saving energy, your options with Mott are almost limitless.

- All of our products are designed to meet the demanding needs of the ever-changing laboratory. We use only the finest materials available in all of our products. Mott is one of the elite few in this industry that is ISO 9001-2008 certified. It is the foundation of our commitment to you. It provides a framework for your satisfaction. It demands a process that works every day, that prevents inevitable mistakes from reoccurring and that is built around our customer. It takes substantial resources to acquire and obtain this certification, but we understand this process is another way we can provide the satisfaction you deserve.

- We have an established international dealer network that is factory trained to furnish, deliver, and install your project competently.

- When considering your next laboratory project, contact Mott Manufacturing to discuss the many ways we can make it better.



QUALITY BY DESIGN

# Certificate of Registration

*This is to certify that QUASAR has registered the Quality Management System of:*



452 Hardy Road, Brantford, ON N3T 5L8

*to the Quality System Standard:*

## ISO 9001:2008

<b>Initial Registration</b> 25 January 2000	<b>Date of Issue</b> 25 May 2012	<b>Date of Expiry</b> 25 May 2015	<b>Certificate Number</b> Q5307
--	-------------------------------------	--------------------------------------	------------------------------------

**Scope:** Design and manufacture of steel laboratory furniture and fume hoods.



Registrar



Terms and Conditions governing registration and the use of this certificate are defined in the contract between QUASAR and the Holder. Contact the certificate holder for further information related to the scope and boundaries of the registration.

*TABLE OF CONTENTS*

ITEM	PAGE
ABOUT MOTT MANUFACTURING.....	I
ISO CERTIFICATION.....	II
STEEL SPECS & OPTIONS.....	A1-A17
STEEL BASE CABINETS.....	B1 - B28
- Standing Height.....	B1
- Sitting Height.....	B13
- ADA Height.....	B22
- Sink Units.....	B25
STEEL WALL CABINETS.....	C1 - C19
- 14" Deep.....	C1
- 18" Deep.....	C9
- Corner Wall Cabinets.....	C17
- Wall Cabinet Options and Accessories.....	C18
STEEL FLOOR CABINETS.....	D1 - D9
- 14" Deep.....	D1
- 18" Deep.....	D3
- 22" Deep.....	D5
- Wardrobe Cabinets.....	D7
- Instrument Storage Cabinets.....	D8
- Tool Storage Cabinets.....	D9
STEEL SPECIALTY CABINETS.....	E1 - E18
- Acid Cabinets.....	E1
- Insulated Solvent Cabinets.....	E4
- Solvent Cabinets.....	E7
- Pump Cabinets.....	E10
- Glassware Drying Cabinets.....	E13
- Security Cabinets.....	E14
- Goggle Cabinet.....	E14
- Recessed Operating Room Cabinets.....	E15
- Sigma Seal™ Cabinets.....	E17
- Specialty Cabinet Vent Hole Locations.....	E18
STEEL SUSPENDED CABINETS.....	F1 - F7
- 24" High.....	F1
- 18-3/4" High.....	F5
- Suspended Components.....	F7
STEEL MISCELLANEOUS ITEMS.....	G1- G30
- Base Filler Panels.....	G1
- Panels & Angels.....	G3
- Tall Filler Panels.....	G4
- Wall Filler Panels.....	G5
- Dust Caps.....	G6
- Light Valances.....	G7
- Front Rails, Aprons and Service Covers.....	G8-G9
- Turret Supports.....	G10
- Support Legs.....	G11
- Components.....	G12
- Service Drops.....	G13-G14
- Cylinder Racks.....	G15
- Reagent Island Shelving Unit.....	G16
- Sigma Flex™ Wall Pilasters, Shelves & Brackets.....	G18
- Sigma Frame™ Wall Pilasters, Shelves & Brackets and Lights.....	G20
- Continuous Slot Metal Framing System.....	G22



## *TABLE OF CONTENTS*

ITEM	PAGE
WOOD SPECS & OPTIONS.....	H1-H15
WOOD BASE CABINETS.....	I1-I27
- Standing Height.....	I1
- Sitting Height.....	I12
- ADA Height.....	I20
- Sink Units.....	I23
WOOD WALL CABINETS.....	J1-J17
- 14" Deep.....	J1
- 18" Deep.....	J9
- Corner Wall Cabinets.....	J17
- Wall Cabinet Options and Accessories.....	J17
WOOD FLOOR CABINETS.....	K1-K10
- 14" Deep.....	K1
- 18" Deep.....	K3
- 22" Deep.....	K5
- Wardrobe Cabinets.....	K7
- Instrument Storage Cabinets.....	K8
WOOD SPECIALTY CABINETS.....	L1-L9
- Acid Cabinets.....	L1
- Solvent Cabinets.....	L4
- Pump Cabinets.....	L6
- Specialty Cabinet Vent Hole Locations.....	L9
WOOD SUSPENDED CABINETS.....	M1-M6
- 24" High.....	M1
- 18" High.....	M5
WOOD MISCELLANEOUS ITEMS.....	N1-N14
- Base Filler Panels.....	N1
- Wall Filler Panels and Light Valances.....	N2
- Front Rails and Service Covers.....	N3
- Aprons and Service Covers.....	N4
- Support Legs.....	N5
- Service Drops.....	N6
- Wood Shelves.....	N7
- Wood Shelving Options.....	N8
- Finished Back Panels.....	N9
- Double Sided Student Workstations.....	N10
- Quad Student Workstations.....	N12
- Two and Four Student Cabinet Storage Tables.....	N14
STAINLESS STEEL PRODUCTS.....	O1-O3
FUME HOODS.....	P1-P53
- Introduction and Terminology.....	P1
- Details.....	P9
- Pro Series Bench Fume Hoods.....	P15
- Low Volume Bench Fume Hoods.....	P20
- Pro Auxiliary Air Bench Fume Hoods.....	P21
- Pro Distillation Fume Hoods.....	P22
- Pro Series Floor Mounted Fume Hoods.....	P23
- Optima™ Floor Mounted Fume Hood.....	P26
- Pro Hopec Bench Fume Hoods.....	P28
- Fully Accessible Bench Fume Hoods.....	P29
- Pro Perchloric Bench Fume Hoods.....	P30

## *TABLE OF CONTENTS*

ITEM	PAGE
FUME HOODS (cont'd).....	P1-P53
- Pro Radioisotope Bench Fume Hoods.....	P31
- Pro Demonstration Bench Fume Hoods.....	P32
- RFV2™ Bench Fume Hoods.....	P33
- Safeguard™ Bench Fume Hoods.....	P35
- Observation™ Island Bench Fume Hoods.....	P37
- Observation™ Bench Fume Hoods.....	P39
- Select Ventilated Work Stations.....	P40
- Wall and Island Exhaust Canopies.....	P41
- Spray Booths.....	P42
- Fume Hood Electrical Services.....	P43
- Fume Hood Fixtures.....	P44
- Fume Hood Accessories.....	P45
- Fume Hood Options.....	P53
MOBILITY.....	Q1-Q34
- Sigma Carts™.....	Q2
- Mobile Tables.....	Q10
- Mobile Cabinets.....	Q13
- Chameleon™ Overhead Service Carriers.....	Q15
- Avion™ Overhead Service Carriers.....	Q18
- Ceiling Service Panels.....	Q20
- Mobile Sink Cabinets.....	Q21
- Heavy Duty Mobile Cart.....	Q22
- Optima™ Mobile Workstation.....	Q25
TABLES.....	R1-R20
- Altus™ Table System.....	R1-R11
- Steel Tables.....	R12
- Crank Tables.....	R16
- Vibration Isolation Tables.....	R17
- Table Components.....	R18
- Wood Tables.....	R19
SIGMA™ FLEX.....	S1-S30
- 12" Deep Island Core Assembly.....	S3
- 8-3/4" Deep Wall Core Assembly.....	S7
- 6" Deep Single Core Island Frames.....	S11
- Countertop Uprights.....	S12
- 3-1/4" Deep Single Core Island Frames.....	S14
- 1" Deep Wall Rails.....	S15
- Core Accessories.....	S19
- Table Frames.....	S24
- Shelves and Brackets.....	S25
- Service Components.....	S29
- Wall Pilasters.....	S30
OPTIMA™ LABORATORY BENCH SYSTEM.....	T1-T32
- Optima™ 2550 Series.....	T2
- Optima™ 2500 Series.....	T3
- Optima™ 2100 Series.....	T17
- Optima™ Components.....	T28
- Optima™ Fixtures.....	T30

*TABLE OF CONTENTS*

ITEM	PAGE
SIGMA FUSION™.....	U1-U6
- Raised Distribution System.....	U4
- Island Core Assemblies.....	U5
- Components.....	U6
SIGMA FRAME™.....	V1-V12
WARRANTY & COLORS.....	W1-W3
- Steel Warranty.....	W1
- Wood Warranty.....	W2
- Revision History.....	W3

*STEEL CASEWORK*

*CASEWORK CONSTRUCTION DETAILS AND SPECIFICATIONS*

**Overview**

**Cabinets**

Each cabinet is fabricated from prime quality furniture grade cold rolled or 304-4 stainless steel. All components are die formed, notched, keyed and tightly fitted to form a mechanically constructed electro spot welded rigid unit.

Each base cabinet incorporates a fully enclosed 4" high by 3" deep toe space at the front of the cabinet base. All base cabinets are provided with four 3/8" diameter leveler bolts accessible through 3/4" diameter pre-punched holes in the cabinet base. Each cabinet is provided with black press plugs to cover access holes after installation. All sink cabinets have galvanized steel bottoms painted to match cabinets.

Base cabinet doors and drawers are interchangeable in the field without special tools. Doors open full width without center posts on 30", 36", 42" and 48" wide base cabinets.

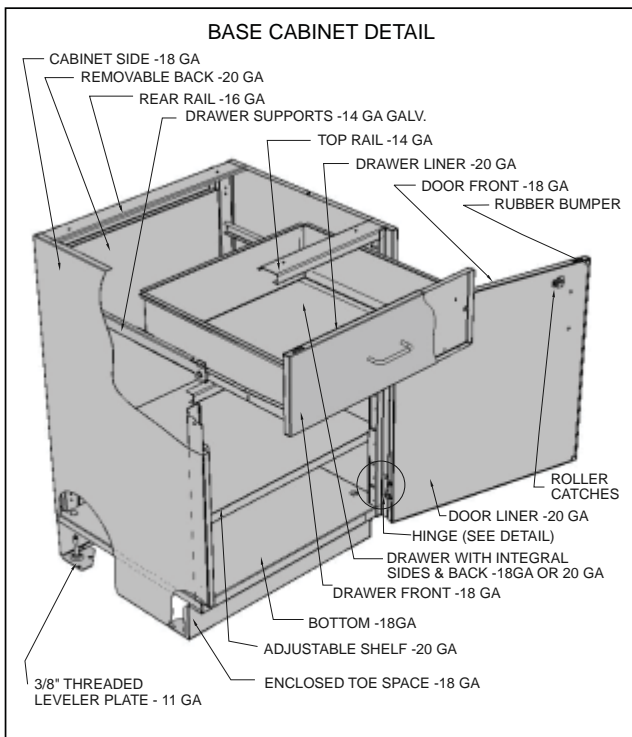

All cupboard units have full height removable back panels, except for sink cabinets which have 9" height removable back panels to facilitate plumbing. All cabinets have been designed to be vermin resistant. Removable backs are optional on drawer units.

**Drawers**

Full access drawer bodies are formed with a one piece, fully coved bottom for effective cleaning, and a reinforcing bend on all top edges. Drawer fronts are 3/4" thick double pan construction. The space between the inner and outer drawer front is filled with a sound deadening core. Drawers have integral stops to prevent accidental withdrawal, and are self closing for the last 6". Drawers are suspended on 1" diameter nylon rollers with steel ball bearings in a radiused galvanized steel track. File drawers are equipped with full extension ball bearing runners and hanging file supports.

**Doors**

Hinged metal doors are 3/4" thick double pan construction with hat channel reinforcements. The space between the inner and outer door front is filled with a sound deadening core. Doors are mounted on high performance 2-1/2" five knuckle 14 gauge hinges, attached with four screws, and are held firmly closed with adjustable nylon roller friction catches. Framed glass doors are supplied with 1/8" (3mm) clear float glass.

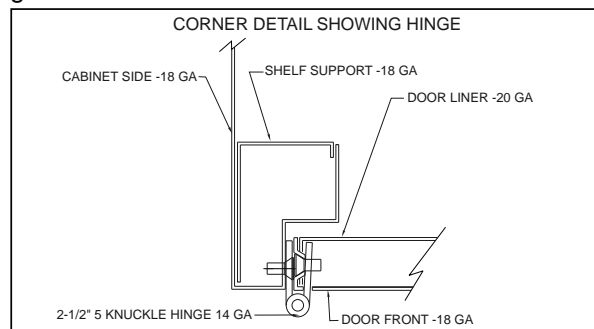

Sliding doors are similar to hinged doors. Each sliding door is top hung with two 1" diameter nylon ball bearing rollers in a steel galvanized double track. The bottom of each door runs in a double PVC track. Rubber bumpers and stops are supplied with all doors.

Unframed glass doors are 1/4" (6mm) clear float glass with ground edges and integral pulls, set in an extruded aluminum shoe with nylon wheels. Doors slide in a top and bottom extruded aluminum track.

All glass supplied in Floor Cabinets (sliding frameless, hinged framed, sliding framed glass door units) is 1/4" (6mm) clear float glass.

**Hardware**

Hardware is not included with products unless specified.

*STEEL CASEWORK  
CASEWORK CONSTRUCTION DETAILS AND SPECIFICATIONS*

**Overview**

**Shelves**

Shelves are fully adjustable on 1/2" increments with all edges formed down and back 1". Pull out shelves are suspended the same as standard drawers.

**Table Frames and Apron Panels**

Frames are 3-3/4" high formed in a "C" channel shape. Table legs are manufactured from 2" x 2" tubing and are through bolted to the table frame, complete with leveling bolts and PVC boots. All drawers are 15" wide and are suspended similar to standard drawers.

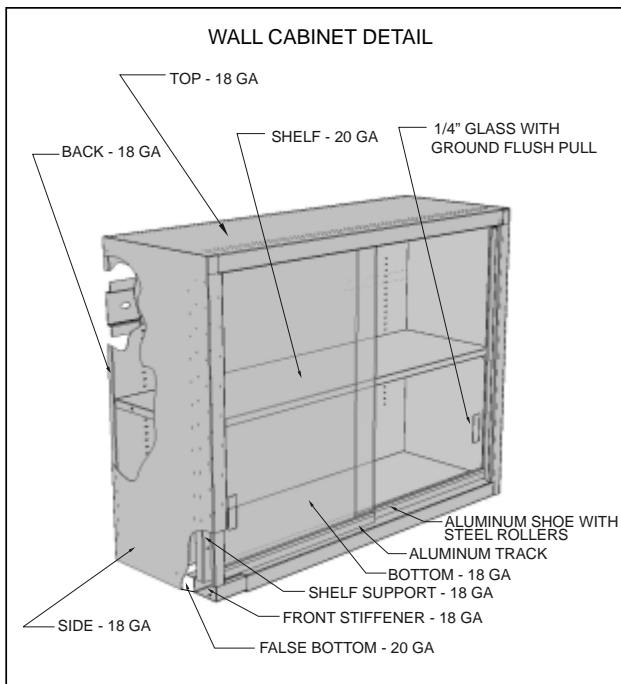

Apron frames and rails are provided with two matching steel end caps to facilitate field cutting to the correct length.

**Lined Acid Storage Cabinets**

Acid cabinets are lined with a chemically resistant molded polyethylene liner (molded liners are removable). 3/16" thick fiberglass reinforced plastic lined cabinets are an available option. Removable liner is held in place with capped stainless steel screws and has a vent connection. Each cabinet has one black phenolic shelf.

**Insulated Solvent Storage Cabinets**

Insulated Solvent Storage cabinets are fabricated with a 2" insulated double wall, are approved to UL1275, and meet National Fire Protection Association

standards. The floor of the cabinet has a 2" deep liquid tight spill containment pan. Doors are mounted on continuous hinges with a three point locking self latching handle. Optional self closing doors are also available. Each cabinet has two 2" diameter vents in the rear of the cabinet, complete with fire baffles and vent covers. Each cabinet has one powder coated steel shelf. Cabinets are marked "FLAMMABLE KEEP FIRE AWAY."

Uninsulated safety cabinets that meet National Fire Protection Association standards are also available.

Standard Cabinet Gauges	
Drawer bodies*, Shelves, Door and Drawer Liners, Removable Backs	20 gauge
Cabinet Gables, Tops, Bottoms, Toekicks, Outer Door and Drawer Front Panels, Table Frames, Filler Panels, Sloping Tops	18 gauge
Top and Intermediate Channels, Table Legs, Base Cabinet Rear Rail	16 gauge
Drawer Suspension, Hinge Plates, Base Cabinet Top Rail	14 gauge
Cabinet Leveler Support	11 gauge

**Drawer Body Note:** \* 30" wide or larger drawers are 18 gauge, otherwise drawers are standard 20 gauge.

**Quality**

Mott laboratory furniture is manufactured to high quality standards. Consistent attention to detail delivers the following outside dimension tolerances.

Item	Finished Tolerance		
	Width	Depth	Height
Cabinetry	+0, -1/16	+0, -1/16	+0, -1/16
Fume Hoods	+0, -1/8	+0, -1/8	+0, -1/8

\*Fume hood under 100" (2540 mm) in width.

**Coating Finish**

All parts are pre-treated with an iron phosphate multi-stage process that includes a final sealer and reverse osmosis water rinse. The result is excellent adhesion between the metal and the coating. All exposed surfaces, including door and drawer head interiors, are electro-statically coated with a thermosetting laboratory grade powder coating.

*STEEL CASEWORK  
SEFA 8 LABORATORY FURNITURE***Recommended Practices**

The Scientific Equipment and Furniture Association (SEFA) is a voluntary international trade association representing members of the laboratory furniture, casework, fume hood, and related laboratory equipment industry. Mott Manufacturing is a SEFA member.

The SEFA mission is to provide a forum for members to identify strategies to improve the quality, safety and timely completion of laboratory facilities to meet customer requirements.

SEFA has developed, through its membership, several recommended practices that are designed to promote better understanding between manufacturers and purchasers and to assist purchasers in selecting and specifying the proper product to meet the user's needs.

The SEFA 8 Recommended Practices provide manufacturers, specifiers, and users tools for evaluating the safety, durability, and structural integrity of laboratory casework.

Mott's line of laboratory furniture meets the performance requirements of the SEFA 8 Recommended Practices. A copy of the SEFA 8 Recommended Practices can be obtained from Mott Manufacturing complete with a certificate confirming the Sigma Systems line of laboratory furniture compliance to this performance standard.

The following is a summary of some of the SEFA 8 performance standards required of a standard 48 inch wide standing height base cabinet.

**Cabinet Physical Strength Performance Tests**

**Cabinet Load Test** - A 2,000 pound test load is mounted on top of a cabinet to evaluate its structural integrity and load bearing capability.

**Cabinet Concentrated Load Test** - A 200 pound center test load is mounted on top of a cabinet to evaluate its functional characteristics.

**Cabinet Torsional Strength Test** - A 200 pound test load is mounted on top of a cabinet which has been raised four inches off the floor with supports under three of the four corners to evaluate the cabinet's structural integrity.

**Door Hinge Test** - A 200 pound test load is hung from a door as it is cycled through the hinge full arc to demonstrate the door and its hardware durability.

**Door Impact Test** - A 240 inch-pound impact test force is applied to the door face to evaluate its impact resistance.

**Door Cycle Test** - A door is swing tested through 90 degrees for 100,000 cycles to evaluate the hinge durability.

**Drawer Load Test** - A 150 pound test load is hung from an opened drawer to demonstrate its ability to support a point load at the drawer front and confirm the attachment of the drawer head to the body.

**Drawer Cycle Test** - A 100 pound static test load is distributed evenly in the drawer and the drawer is cycled 50,000 times from the fully open to fully closed position to confirm a reasonable life of the drawer slide mechanism under full load.

**Drawer and Door Pull Test** - A 50 pound test load is applied to the pull to evaluate the strength of the pull and its mounting hardware.

**Drawer Impact Test** - A 10 pound test load is dropped into an open drawer to evaluate the drawer and slide mechanism impact resistance.

**Cabinet Surface Coating Performance Tests**

**Chemical Spot Test** - The coated surface is exposed to 49 specified chemical reagents commonly found in laboratory applications to evaluate its resistance to chemical spills.

**Hot Water Test** - The coated surface is tested to evaluate its resistance to hot water.

**Impact Test** - A one pound ball is dropped on the surface to evaluate the coating's ductility.

**Adhesion Test** - A scratch test conducted according to ASTM D2197-86 is conducted to confirm adequate coating adhesion.

**Hardness Test** - A 4H pencil lead is used to determine the hardness of the coating.



*STEEL CASEWORK  
TYPICAL WORK AREA*

**Details**

The following details are provided to illustrate how base cabinets, filler panels and countertops combine to construct a laboratory work area.

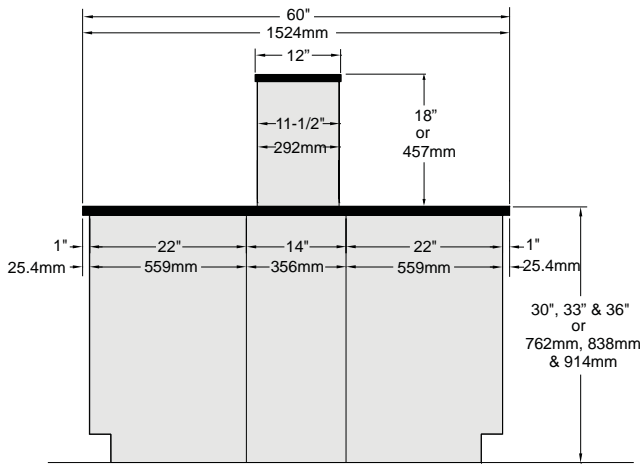

Island type configuration with 60" wide counter top, base cabinets, 14" filler panel and reagent shelf. A large space for services is concealed behind the 14" filler panel.

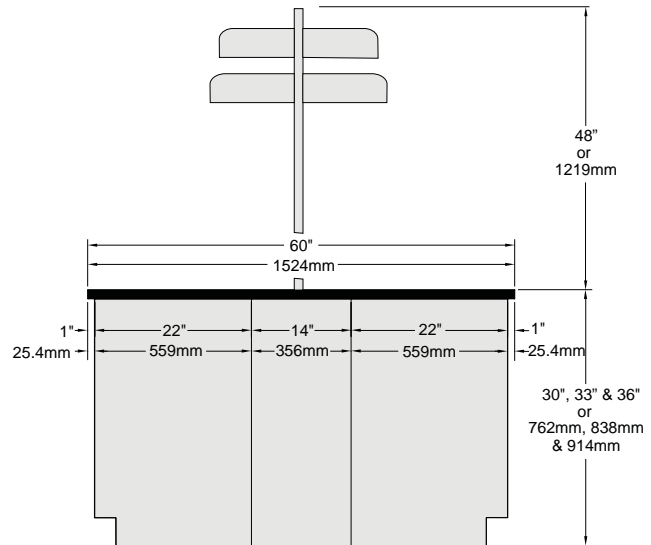

Island type configuration with 60" wide counter top, base cabinets and 14" filler panel. Optional center post assembly with shelving. A large space for services is concealed behind the 14" filler panel.

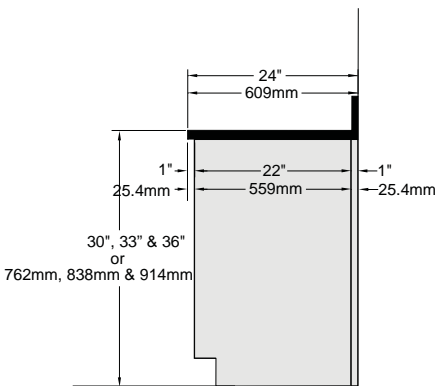

Standard base cabinet configuration with 24" wide counter top, base cabinet and filler 1" panel.

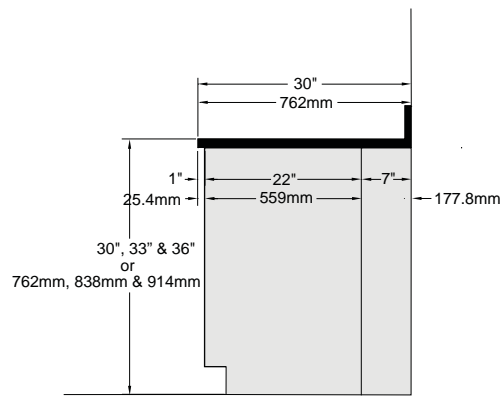

Base cabinet configuration with 30" wide counter top, base cabinet and filler 7" panel. The area covered by the 7" filler panel provides space for required services.

*STEEL CASEWORK  
OPTIONAL METRIC SIZES*

**Base Cabinets**

Mott base cabinets are also available in metric widths of 513mm or 1000mm. The information below indicates the dimensions of metric base cabinets. To order metric base cabinets contact your nearest Mott dealer.

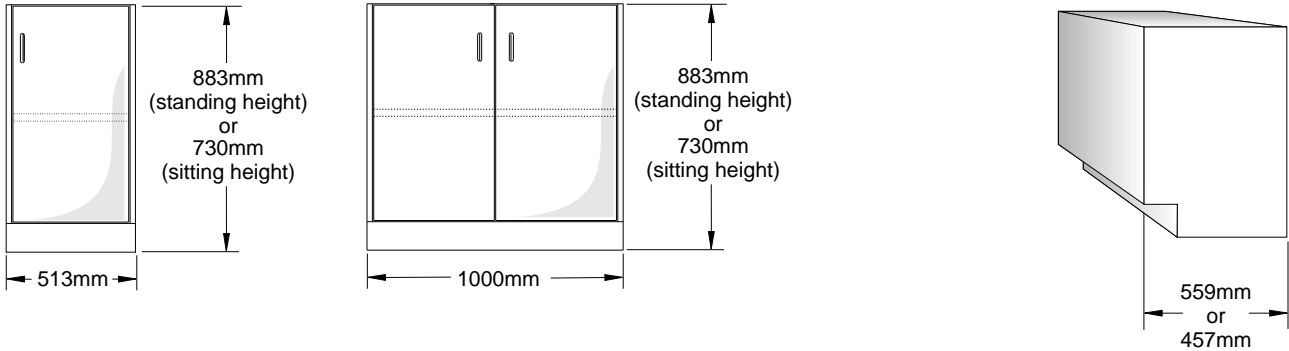

Note: 457mm available on selected specialty cabinets only.

**Wall Cabinets**

Mott wall cabinets are also available in metric widths of 513mm or 1000mm. The information below indicates the dimensions of metric wall cabinets. To order metric wall cabinets contact your nearest Mott dealer.

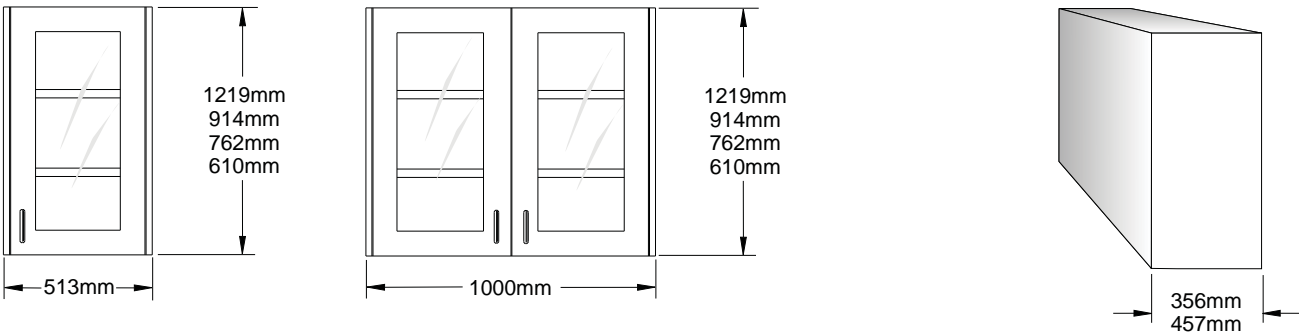

*STEEL CASEWORK  
OPTIONAL METRIC SIZES*

**Floor Cabinets**

Mott floor cabinets are also available in metric widths of 513mm or 1000mm. The information below indicates the dimensions of metric floor cabinets. To order metric floor cabinets contact your nearest Mott dealer.

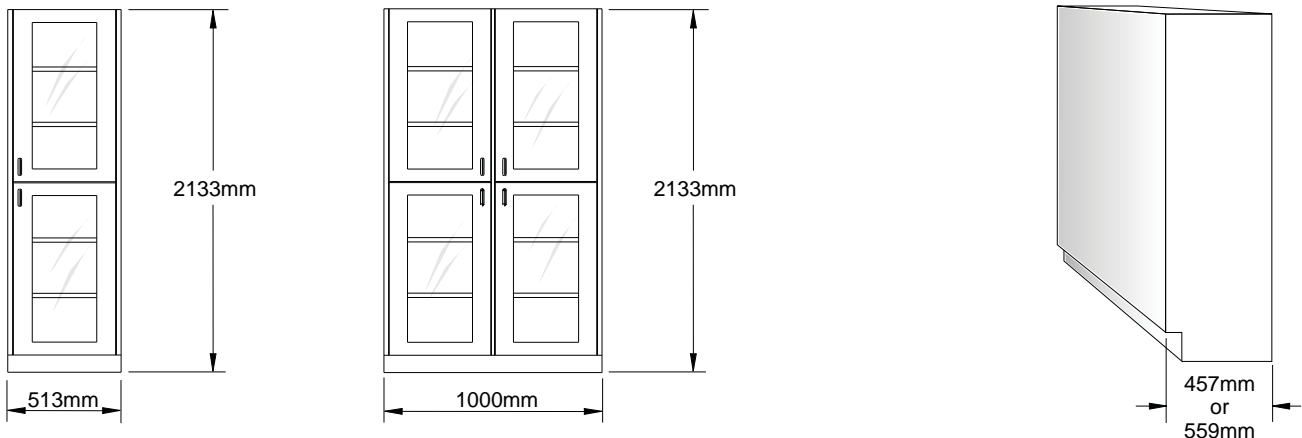

**Aprons and Tables**

Mott aprons and tables are also available in metric widths of 513mm, 1000mm and 1513mm. The information below indicates the dimensions of metric aprons and tables. To order metric aprons and tables contact your nearest Mott dealer.

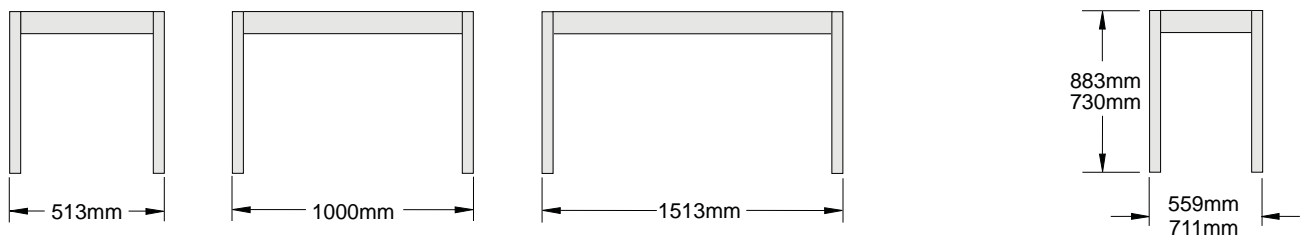

**Miscellaneous Items**

Mott miscellaneous items such as dust caps, filler panels, etc. are also available in metric widths. To order these items contact your nearest Mott dealer.

*STEEL CASEWORK  
OPTIONAL METRIC SIZES*

**Fume Hoods**

Mott fume hoods are also available in metric widths of 1000mm, 1513mm and 2000mm. The information below indicates the dimensions of metric fume hoods. To order metric fume hoods contact your nearest Mott dealer.

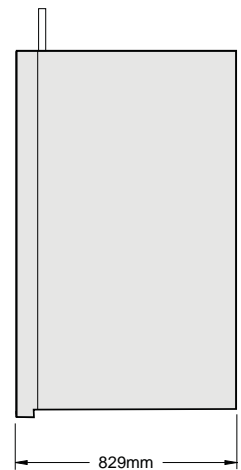
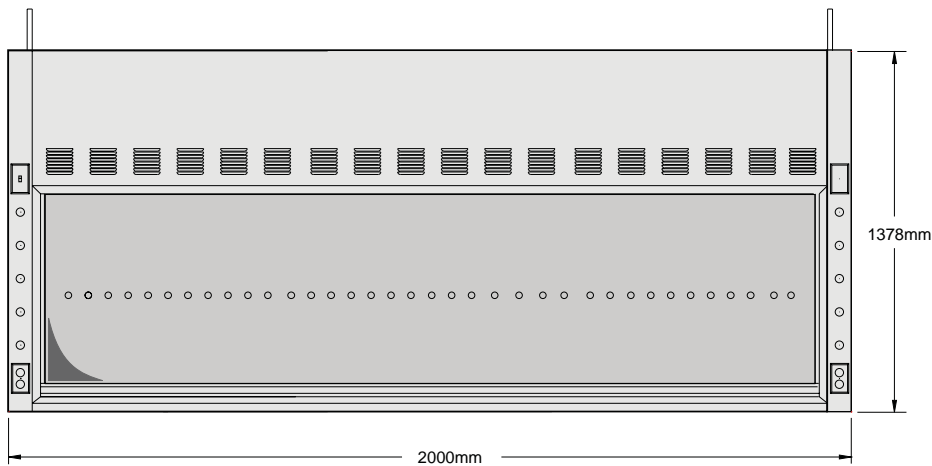
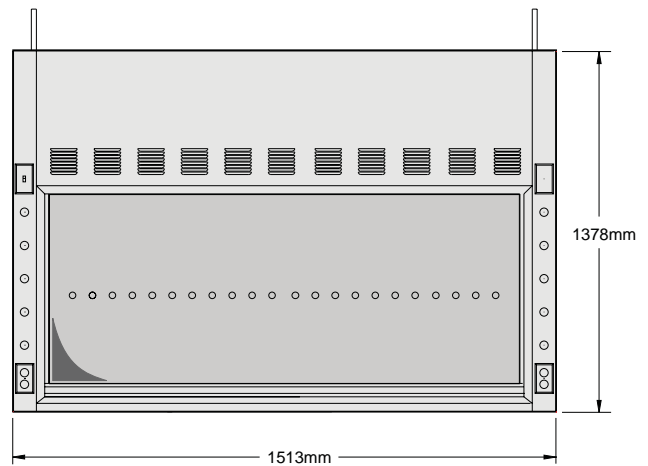
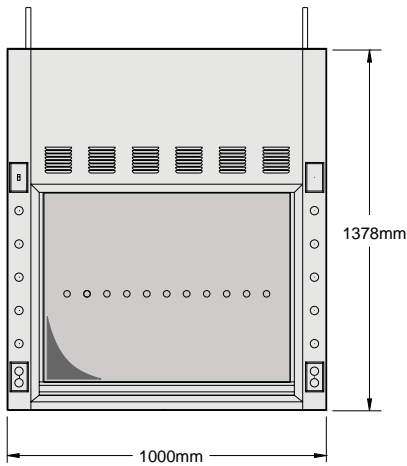

*STEEL CASEWORK  
HANDLE & HINGE OPTIONS*

**Door/Drawer Pulls**

*\*Available at an additional charge*

There are several different styles of door/drawer handles that are offered to suit specific customer requirements. Please use the option numbers below to specify the handle of your choice.



**OPTION 60**  
*4" Black Nylon Pull*



**\*OPTION 61**  
*4" Stainless Steel Wire Pull*  
**OPTION 68**  
*4" Aluminum Wire Pull*



**OPTION 62 - Standard**  
*4" Brushed Aluminum Pull*



**OPTION 63**  
*4" Chrome Pull*

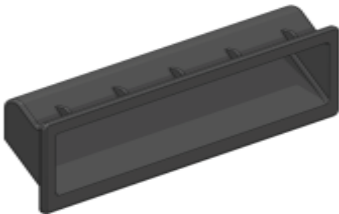

**OPTION 64**  
*4" Black Flush ABS Pull*



**OPTION 65**  
*4" Flush Aluminum Pull  
For Sliding Doors*



**OPTION 65**  
*4" Flush Aluminum Pull  
For Doors and Drawers*

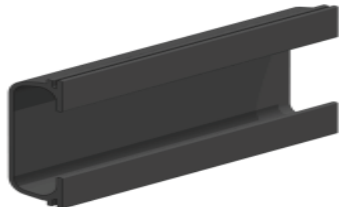

**OPTION 66**  
*4" Black Flush PVC Pull  
For Sliding Doors*

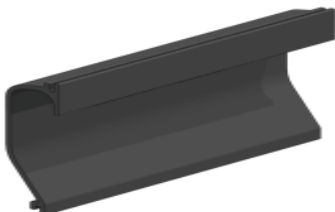

**OPTION 66**  
*4" Black Flush PVC Pull  
For Doors and Drawers*



**\*OPTION 67**  
*Flush Full Width Pull*

**Door Hinges**

*\*Available at an additional charge*

Mott cabinets come with durable 14 gauge five knuckle hinges. The hinges are available in black powder coat, chrome plated or stainless steel finishes. Please use the option numbers below to specify the hinge of your choice.



**OPTION 21 - Standard**  
*Chrome Hinge*  
**OPTION 22**  
*Black Hinge*  
**\*OPTION 23**  
*Stainless Steel Hinge*



**\*OPTION 20**  
*Dull Chrome Overlay Hinge*  
**\*OPTION 24**  
*Stainless Steel Overlay Hinge*

*STEEL CASEWORK  
OPTIONS*

**Ordering Architectural Overlay**

Mott laboratory furniture is available with a wide variety of features to meet specific application requirements. The full range of Mott cabinetry - from base cabinets to tall floor mounted cabinets - is available in our Architectural Overlay design. To specify Architectural Overlay, select the two digit part number suffix from below and add this suffix after the standard part number, separated with a dash.

**OVERVIEW EXAMPLE**

To order architectural overlay on a drawer/door cabinet.

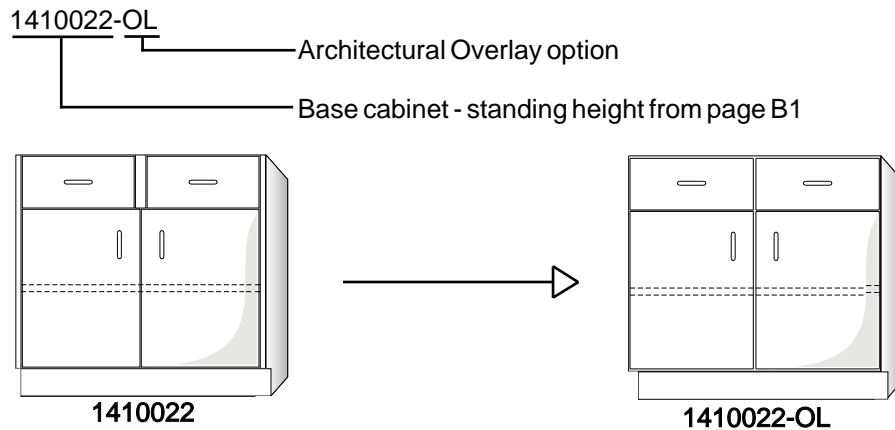

**Ordering Double Sided Wall Units**

Mott laboratory furniture is available with a wide variety of features to meet specific application requirements. The full range of our Mott wall cabinets are available in our double sided design. To specify double sided wall cabinets, select the two digit part number suffix from below and add this suffix after the standard part number, separated with a dash.

**OVERVIEW EXAMPLE**

To order double sided wall cabinets.

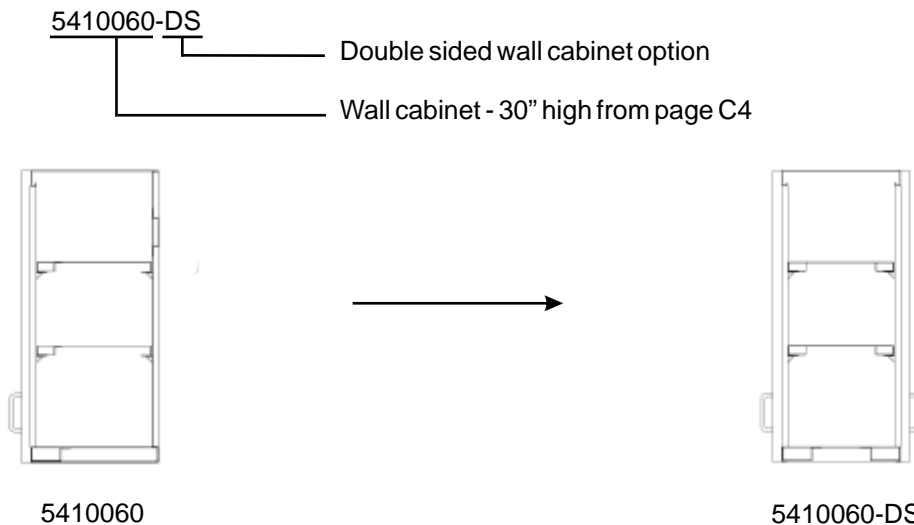



*STEEL CASEWORK  
OPTIONS*

**Ordering Sigma Barrier™ Units**

Mott's Sigma Barrier™ coating provides excellent moisture and corrosion resistance in applications that involve high levels of wetness and humidity. Sigma Barrier™ protects steel from rusting in wet environments by not only forming a protective barrier between the steel and the environment, but also going one step further than paint, to provide electrochemical protection of the steel.

**Complete protection** - Every part of a Sigma Barrier™ article is protected, including recesses, sharp corners and inaccessible areas. Mott's thermosetting laboratory grade powder coating delivers excellent chemical and scratch resistance, but the Sigma Barrier™ coating provides additional defense from tough lab environments.

**Toughest coating** - Mott's Sigma Barrier™ special galvanized coating has a unique metallurgical structure, which gives outstanding resistance to damage that can occur in transport, installation and servicing.

**Full Range of Cabinetry and Components** - The full range of powder coated Mott cabinetry, hoods and miscellaneous components are available with the Sigma Barrier™ coating to meet your lab's specific requirements.

Contact Mott for detailed Sigma Barrier™ test results.

**OVERVIEW EXAMPLE**

To add Sigma Barrier™ coating to a cabinet.

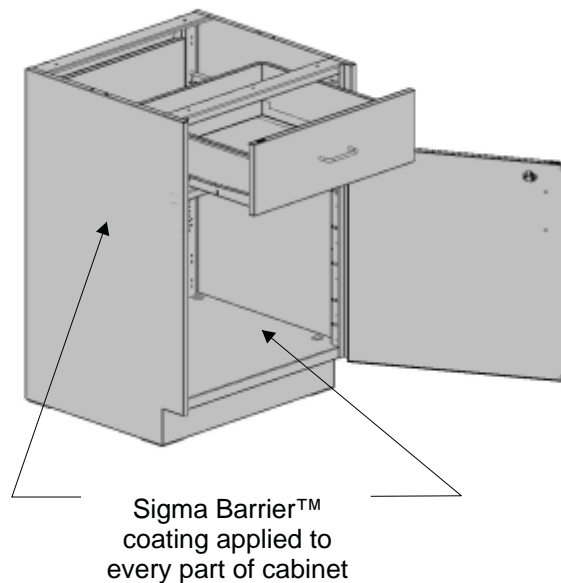
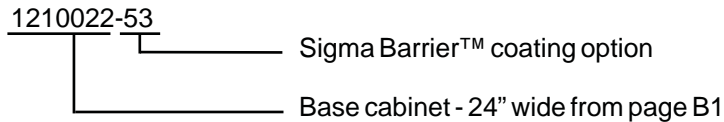

*STEEL CASEWORK  
OPTIONS*

**Ordering Special Features**

Mott laboratory furniture is available with a wide variety of features to meet specific application requirements. To specify any feature, select the two digit part number suffix from the list below and add this suffix after the standard part number, separated with a dash.

**OVERVIEW EXAMPLE**

To order chrome hinges, brushed aluminum pulls, and a pull-out shelf on a drawer/door cabinet.

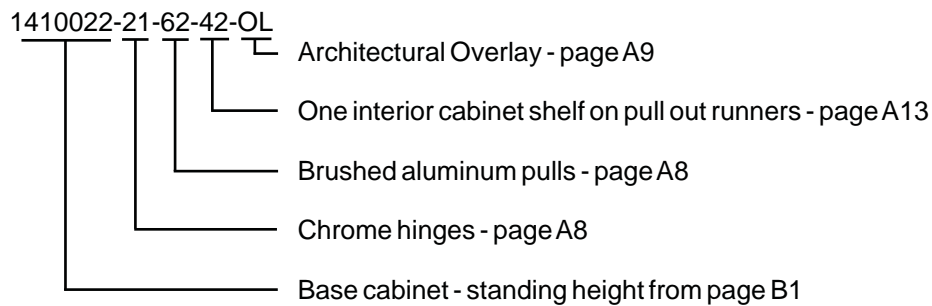

**HOW TO SPECIFY FEATURES**

Two steps are required to specify the chosen option for each furniture component.

**STEP ONE - COMPULSORY FEATURES**

The appropriate hinge and handle option must be specified for each cabinet (except solvent storage) and tables without drawers.

**Door Hinges**

One option must be selected from this option group for cabinets that require door hinges. See page A8 for hinge details.

Option #	Description
21	Chrome hinges (Standard)
22	Black steel hinges
23	Stainless steel hinges
24	Stainless steel overlay hinges
29	Other customer specific hinge - <i>see note 9</i>

**Door and Drawer Pulls**

One option must be selected from this option group for cabinets that require door and drawer pulls. See page A8 for door and drawer pull details.

Option #	Description
16	Ship handles not installed
60	Black nylon pull
61	Stainless steel wire pull
62	Brushed aluminum pull (Standard)
63	Chrome pull
64	Flush black ABS pull
65	Flush aluminum pull
66	Flush PVC black pull
67	Full width flush pull
68	Aluminum wire pull
69	Other customer specified pull - <i>see note 9</i>
6A	Recessed stainless steel tapered pull

*STEEL CASEWORK  
OPTIONS*

**Ordering Special Features**

**STEP TWO - OPTIONAL FEATURES**

Select any of the following options as the application requires.

**Option #      Description**

**Cabinet & Miscellaneous Options**

00	Required cabinet has drawer and/or door configuration similar to basic part noted. A minor configuration change is required with no changes in the cabinets outside dimensions from the basic part number specified - <i>see note 1</i>
01	Full extension drawer runners
02	Label holders on all doors/drawers
03	Numeric or alpha identification disks on all doors/drawers - <i>see note 2</i>
04	Standard louver configuration on doors - <i>see note 3</i>
05	Non-standard louver configuration on doors - <i>see note 1</i>
07	Cut-outs for electrical and/or plumbing services - <i>see note 1</i>
08	Security proof panel
09	Stainless steel waste flap
10	One drawer divider per drawer - <i>see note 14</i>
11	Multiple drawer dividers per drawer - <i>see note 1</i>
12	Pull out writing board - all cold rolled steel - <i>see note 8</i>
13	Pull out writing board - cold rolled steel & high pressure laminate writing surface - <i>see note 8</i>
14	Ventilation grill in toe kick base - <i>see note 1</i>
15	Finished back on cabinet
17	Nylon levelers
18	Horizontally mounted handles
19	Full width drawer on 5" high apron
26	200 lbs full extension drawer runners
37	Hasp locks
48	Keyboard tray (replace drawer)
82	FRP liner for acid cabinets - <i>see note 4</i>
83	Self closing and latching doors for solvent cabinets
84	Galvanized bin insert
85	PVC bin insert for waste bin units.
86	No casters on Sigma Cart™
89	Lazy susan storage unit for corner cabinets
90	Sink supports - <i>see note 6</i>
96	Stainless steel boots on leg frame
AD	Add - a - drawer design - <i>see note 18</i>
BL	"Base" label (use this option code to replace standard label on Acid cabinets)
CL	Corrosive label
DL	Fluorescent light for specialty recessed drawer desk unit
DA	1" Double angle
F1	Welded finished top
F2	Welded finished top and back
FL	Fusible Link with self closer for Insulated Solvent Unit - <i>see note 7</i>
LA	Bilingual label (English/French)
LF	Longitudinal file
ME	Manual eyewash for Mobile Sink Cabinet
MF	Manual faucet for Mobile Sink Cabinet
NB	No base on cabinet to sit on floor
NC	No base on cabinet to sit on 4" high curb
NF	Pump Cabinet Unit with no cabinet floor and toe kick is integral with door
NFD	Pump Cabinet Unit with no cabinet floor and toe kick is integral with door, dolly included
OL	Overlay design
PF	Pump cabinet fan

*STEEL CASEWORK  
OPTIONS*

**Ordering Special Features**

**STEP TWO - OPTIONAL FEATURES**

Select any of the following options as the application requires.

**Option #      Description**

**Cabinet & Miscellaneous Options (Continued)**

PC	Foot pedal cutouts centered
PL	Foot pedal cutout left hand side
PR	Foot pedal cutout right hand side
PP	Pre-plumbed (option code not to be used for fume hoods) - <i>see note 2</i>
PW	Pre-wired (option code not to be used for fume hoods) - <i>see note 2</i>
RB	Removable back on drawer cabinet
RL	Remote LED light for narcotic cabinet
SK	Skid item
SP	Silk Screen Printing (to replace standard labels on Acid and/or Flammable cabinets)
VS	Vent holes on side of cabinet.
VK	Corrugated polyolefin vent kit for acid cabinets
WF	Wood fronts - <i>see specification</i>
WS	Supply hose to hook up with facility water supply for Mobile Sink Cabinet
40	One extra cabinet shelf - <i>see note 5</i>
41	Two extra cabinet shelves - <i>see note 5</i>
42	One interior cabinet shelf on pull-out runners - <i>see note 15</i>
43	Two interior cabinet shelves on pull-out runners - <i>see note 15</i>
44	Three interior cabinet shelves on pull-out runners - <i>see note 15</i>
T1	One pull out tray on full extension runners with 2" high lip - <i>see note 19</i>
T2	Two pull out trays on full extension runners with 2" high lip - <i>see note 19</i>
T3	Three pull out trays on full extension runners with 2" high lip - <i>see note 19</i>

**Wall Cabinet Options**

SL	Seismic lip
ZR	"Z" mounting rail
DS	Double sided wall cabinet - <i>see page A9</i>
FR	Special mounting provisions for wall cabinets to suspend from Sigma Flex™
HR	Special mounting provisions for wall cabinets to suspend from Sigma Frame™

**Floor Cabinet Options**

80	Full height doors for floor cabinets
81	Coat rod for wardrobe for floor cabinets

**Cabinet Locking Options**

30	Standard locks on doors/drawers supplied and factory installed - <i>see note 10</i>
31	Provisions for standard locks on doors/drawers (holes & tabs) - <i>see note 10</i>
37	Provisions for Hasp Locks (padlocks not included)
38	Other customer specified locks on doors/drawers supplied and factory installed - <i>see note 9</i>
39	Other customer specified locks on doors/drawers supplied and not factory installed - <i>see note 9</i>
BS	Best locks (housing only), core sold separately
LK4	Standard 5 pin tumbler lock with removable core, three level keying

**Shelf Options**

AR	Rear shelf angle welded to shelf
AF	Front shelf angle welded to shelf
AB	Front and rear shelf angle welded to shelf
NN	No alignment tabs on SBP brackets

*STEEL CASEWORK  
OPTIONS*

**Ordering Special Features**

**STEP TWO - OPTIONAL FEATURES**

**Option #      Description**

**Glass Options**

45	DuoLite safety glass - <i>see note 12</i>
46	Tempered glass - <i>see note 12</i>
47	Customer specified glass - <i>see note 12</i>
4A	Glass Tint 44% (Grey Smoke)

**Cabinet Material Options**

50	304 stainless steel drawer bodies in powder coated cold rolled steel cabinet
51	Entire 304 stainless steel component
52	Entire 316 stainless steel component
53	Sigma Barrier™ galvanized steel coating - <i>see note 13</i>
54	304 stainless steel drawer bodies in Sigma Barrier™ galvanized steel cabinet
56	Other customer specified material

**Base Cabinet Options**

70	Front toe kick
71	Toe kick - front & left side - <i>see note 16</i>
72	Toe kick - front & right side - <i>see note 16</i>
73	Toe kick - front & 2 sides - <i>see note 16</i>
74	Toe kick - front & back - <i>see note 16</i>
75	Toe kick - front, back, & 2 sides - <i>see note 16</i>
76	Replace toe kick base with 4 legs
77	Replace cabinet toe kick base with casters and tip prevention counterweights (casters & hardware shipped loose)
78	Replace cabinet toe kick base with customer specified casters - <i>see note 9</i>
79	Other customer specified base and/or toe kick - <i>see note 1</i>
BF	Replace toe kick with 4" stainless steel adjustable bullet feet

**Table Options (does not apply to Optima and Altus)**

06	One fixed shelf on "O" frame
48	Keyboard tray (replaces drawer)
49	Stainless steel adjustable height legs. Legs are adjustable in 1" increments, from 28-3/4" high to 34-3/4" high.
87	Mobile table complete with casters - <i>see note 11</i>
88	Mobile table complete with customer specified casters - <i>see note 9</i>
91	Table with no supports - <i>see note 20</i>
92	"U" frame table with rear & side supports
93	Left side table leg - no supports
94	Right side table leg - no supports
95	Front table legs - no supports
HU	"U" frame table with floating rail to hang cabinets for TAC tables
OL	When ordering a table with drawers to match Architecture Overlay design
WA	Welded table assembly - <i>see note 17</i>

**Adjustable Height Science Table**

EM	Height adjustment option - integral electric motor for height adjustable Science Table
CD	Height adjustment option - powered with hand held cordless drill for height adjustable Science Table
CU	CPU hold that suspends computers below work surface
BH	Hook for hanging book bags below work surface
MS	Powder coated steel modesty panels
MW	Wood veneer modesty panels - <i>see specifications</i> - <i>see note 2</i>

*STEEL CASEWORK  
OPTIONS*

**Ordering Special Features**

**STEP TWO - OPTIONAL FEATURES**

**Option #      Description**

**Optima™ Laboratory Bench Systems Options**

1B	Single sided bulletin board on Optima™
2B	Double sided bulletin board on Optima™
1E	One Electrical Circuit on 48"w 2100 Series Optima™
2E	One Electrical Circuit on 60"w or 72"w or 96"w 2100 Series Optima™
3E	Two Electrical Circuits on 60"w or 72"w or 96"w 2100 Series Optima™
C1	Two Electrical Circuits on 48"w 2500 Series Optima™
C2	Two Electrical Circuits on 60"w or 72"w or 96"w 2500 Series Optima™
C3	Four Electrical Circuits on 48"w 2500 Series Optima™
C4	Four Electrical Circuits on 60"w or 72"w or 96"w 2500 Series Optima™
CR	Powder Coated Retainer Rod
SR	Stainless Steel Retainer Rod
97	Casters and Stretches for OTF tables
98	Customer specified casters with stretchers for OTF tables - see note 9

**Sigma Fusion™ Options**

FM	Special mounting provisions for wall cabinets to suspend from Sigma Fusion™
----	---

**Sigma Flex™ Options**

R1	Sigma Flex™ Island Service Drop for 12" deep assemblies
R3	Sigma Flex™ Wall Service Drop on right side for 8-3/4" deep Wall Core assemblies
R4	Sigma Flex™ Wall Service Drop on left side for 8-3/4" deep Wall Core assemblies

**Sigma Cart™ Options**

AL	Pair of supplementary adjustable height table legs for Sigma Carts™
SF	Stationary feet with levelers
VI	Vibration isolators for Heavy Duty Cart. Note: With this option you cannot suspend cabinets.

**Overhead Service Options**

AC	Dust cap for Avion™ Service Carrier
SD	Service Drop for Chameleon™ Service Carrier

**Altus™ Table System Options**

D1	One electrical circuit on 48"w, 60"w or 72"w Altus™ Table System
D2	Two electrical circuit on 48"w, 60"w or 72"w Altus™ Table System
CR	Powder Coated Retainer Rod
SR	Stainless Steel Retainer Rod
97	Casters and Stretches for ATF tables
98	Customer specified casters with stretchers for ATF tables - see note 9

**Optima™ Mobile Workstation Options**

CR	Powder Coated Retainer Rod
SR	Stainless Steel Retainer Rod



*STEEL CASEWORK  
OPTIONS*

**Lock and Key Options**

**All Locks Keyed Different Per Unit**

Locks are keyed different per unit from other units.

Note: This is the standard key schedule with disc tumbler lock supplied for option code 30 unless otherwise specified.

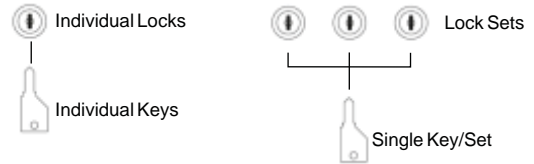

**All Locks Keyed Alike**

All locks are keyed alike, each lock can be opened with a single key.

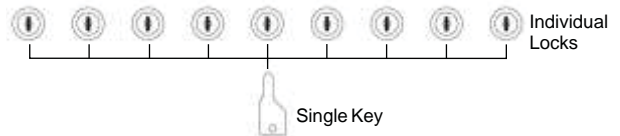

**All Locks Keyed Different**

Locks are keyed different from other locks. Up to 229 key changes for disc are available.

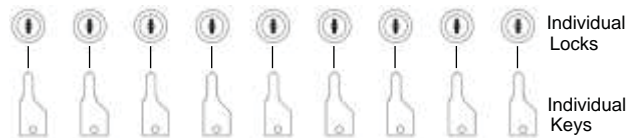

**Locks Keyed Alike in Sets**

Locks are keyed alike in sets. Only one key will open one set of locks within the set. Up to 229 key changes for disc are available.

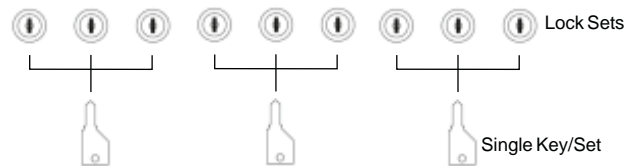

**Master Keyed Locks**

All locks are keyed different from all other locks. Each set within a group can be opened with a master key. Up to 229 key changes for disc are available.

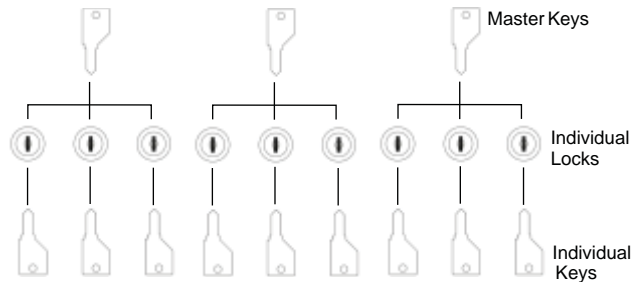

**All Pin Locks Keyed Different - Grand Master & Master Keyed**

All locks are keyed different from all other locks. Each set within a group can be opened with a master key. All groups can be opened with a grand master key. Grand Master only available in pin style locks.

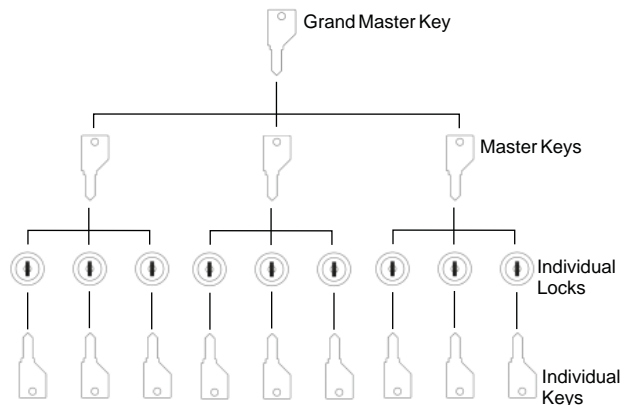

*STEEL CASEWORK  
OPTIONS*

**Ordering Special Features**

**EXPLANATORY NOTES FOR OPTION CODES**

1. Full dimensional and descriptive details (preferably including a sketch) must be included with the order.
2. Full descriptive details must be included with the order.
3. Standard louver configuration is one block of 6 louvers located near the bottom center of each door, each louver is approximately 3" wide by 5-1/2" long.
4. Use this option code to have cabinet lined with FRP instead of molded liner.
5. Standard number of removable shelves per base cabinet with door(s) or wall cabinet is noted in the cabinet drawings of this catalog.
6. Sink support kit is required for under-counter mounted sinks used with Imperial Stone or Epoxy counter tops. Sink support kit not normally required for self rimming or integrally welded sinks.
7. Designed for use on solvent cabinets with self-closing and latching doors (option code 83). A fusible link holds doors open during use and melts at 165°F to automatically close doors in the event of a fire.
8. Option 12 - Pull out board is powder coated cold rolled steel. Option 13 - Pull out board is powder coated cold rolled steel with high pressure laminate writing surface. Standard pull out board is 15" wide, 2 boards are supplied on 48" wide units and larger.
9. Provide complete specification and source for all special options ordered.
10. Standard lock is a disc tumbler lock. Each cabinet is keyed different per unit unless otherwise specified.
11. Standard 4" high casters are swivel with rolling brake.
12. Standard glass is as follows:
 

All framed glass and sliding glass Floor Cabinets	1/4" (6mm) float glass
Sliding glass door Wall Cabinets	1/4" (6mm) float glass
Framed glass door Wall Cabinets	1/8" (3mm) float glass
13. Sink units are constructed with satin coat (galvanized) inner horizontal bottom base plate as standard.
14. Drawer divider runs depth of drawer.
15. Pull-out shelves replace standard removable shelf in base cabinets with door(s).
16. Cabinet left and right are determined when facing the cabinet front.
17. This option code applies to Table Frames with part numbers starting with TAC, TAA, TAB, TCC, TCB and TCE.
18. Removable top drawer unit is 6" high.
19. Pull out tray replaces standard removable shelf in base cabinets with door(s). Tray is non-removable.
20. Tables may be supplied without a lower H or U frame if the table width is 48" or less, and/or the required load is 200lbs or less. All tables may be supplied without a lower H or U frame and support a 600lb load if all legs are bolted securely to the floor. (ie: seismic design).

*STEEL CASEWORK  
BASE CABINETS - STANDING HEIGHT*

**Open Units**



Width	Item Number
15"	1910000
18"	1110000
24"	1210000
30"	1310000
36"	1410000
42"	1810000
48"	1510000
513mm	1610000
1000mm	1710000

**Full Door Units**



up to 24" wide



30" and wider

Width	Right Hinged	Left Hinged	# of Doors
12"	1010011	1010211	1
15"	1910011	1910211	1
18"	1110011	1110211	1
24"	1210011	1210211	1
30"	1310011	-	2
36"	1410011	-	2
42"	1810011	-	2
48"	1510011	-	2
513mm	1610011	1610211	1
1000mm	1710011	-	2

**Door/Drawer Units**



up to 24" wide



30" and wider

Width	Right Hinged	Left Hinged	# of Doors
12"	1010022	1010222	1
15"	1910022	1910222	1
18"	1110022	1110222	1
24"	1210022	1210222	1
30"	1310022	-	2
36"	1410022	-	2
42"	1810022	-	2
48"	1510022	-	2
513mm	1610022	1610222	1
1000mm	1710022	-	2



up to 24" wide



30" and wider

Width	Right Hinged	Left Hinged	# of Doors
15"	1910033	1910233	1
18"	1110033	1110233	1
24"	1210033	1210233	1
30"	1310033	-	2
36"	1410033	-	2
42"	1810033	-	2
48"	1510033	-	2
513mm	1610033	1610233	1
1000mm	1710033	-	2

*STEEL CASEWORK  
BASE CABINETS - STANDING HEIGHT*

**Door/Drawer Units**

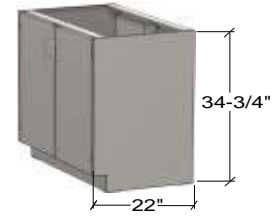

Width	Item Number
30"	1310093
36"	1410093
42"	1810093
48"	1510093
1000mm	1710093



Width	Item Number
30"	1310096
36"	1410096
42"	1810096
48"	1510096
1000mm	1710096



Width	Left Hand	Right Hand
30"	1310023	1310032
36"	1410023	1410032
42"	1810023	1810032
48"	1510023	1510032
1000mm	1710023	1710032

- Left hand Door/Drawer Unit shown.
- Right hand Door/Drawer Units are reverse of what is shown.



Width	Left Hand	Right Hand
30"	1310012	1310021
36"	1410012	1410021
42"	1810012	1810021
48"	1510012	1510021
1000mm	1710012	1710021

- Left hand Door/Drawer Unit shown.
- Right hand Door/Drawer Units are reverse of what is shown.



Width	Left Hand	Right Hand
30"	1310013	1310031
36"	1410013	1410031
42"	1810013	1810031
48"	1510013	1510031
1000mm	1710013	1710031

- Left hand Door/Drawer Unit shown.
- Right hand Door/Drawer Units are reverse of what is shown.

*STEEL CASEWORK  
BASE CABINETS - STANDING HEIGHT*

**Door/Drawer Units**



Width	Left Hand	Right Hand
30"	1310014	1310041
36"	1410014	1410041
42"	1810014	1810041
48"	1510014	1510041
1000mm	1710014	1710041

- Left hand Door/Drawer Unit shown.
- Right hand Door/Drawer Units are reverse of what is shown.



Width	Left Hand	Right Hand
30"	1310015	1310051
36"	1410015	1410051
42"	1810015	1810051
48"	1510015	1510051
1000mm	1710015	1710051

- Left hand Door/Drawer Unit shown.
- Right hand Door/Drawer Units are reverse of what is shown.



Width	Left Hand	Right Hand
30"	1310016	1310061
36"	1410016	1410061
42"	1810016	1810061
48"	1510016	1510061
1000mm	1710016	1710061

- Left hand Door/Drawer Unit shown.
- Right hand Door/Drawer Units are reverse of what is shown.



Width	Left Hand	Right Hand
30"	1310017	1310071
36"	1410017	1410071
42"	1810017	1810071
48"	1510017	1510071
1000mm	1710017	1710071

- Left hand Door/Drawer Unit shown.
- Right hand Door/Drawer Units are reverse of what is shown.



Width	Left Hand	Right Hand
30"	1310018	1310081
36"	1410018	1410081
42"	1810018	1810081
48"	1510018	1510081
1000mm	1710018	1710081

- Left hand Door/Drawer Unit shown.
- Right hand Door/Drawer Units are reverse of what is shown.
- If locks are required, the lowest drawer of the cabinet will require a slot in the bottom of the drawer body to accommodate the lock cam.

*STEEL CASEWORK  
BASE CABINETS - STANDING HEIGHT*

**Door/Drawer Units**

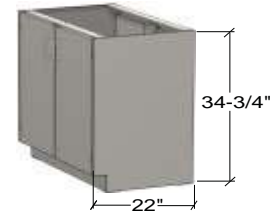

Width	Left Hand	Right Hand
30"	131001B	13100B1
36"	141001B	14100B1
42"	181001B	18100B1
48"	151001B	15100B1
1000mm	171001B	17100B1

- Left hand Door/Drawer Unit shown.
- Right hand Door/Drawer Units are reverse of what is shown.



Width	Left Hand	Right Hand
30"	1310924	1310942
36"	1410924	1410942
42"	1810924	1810942
48"	1510924	1510942
1000mm	1710924	1710942

- Left hand Door/Drawer Unit shown.
- Right hand Door/Drawer Units are reverse of what is shown.



Width	Left Hand	Right Hand
30"	1310024	1310042
36"	1410024	1410042
42"	1810024	1810042
48"	1510024	1510042
1000mm	1710024	1710042

- Left hand Door/Drawer Unit shown.
- Right hand Door/Drawer Units are reverse of what is shown.



Width	Left Hand	Right Hand
30"	1310025	1310052
36"	1410025	1410052
42"	1810025	1810052
48"	1510025	1510052
1000mm	1710025	1710052

- Left hand Door/Drawer Unit shown.
- Right hand Door/Drawer Units are reverse of what is shown.



Width	Left Hand	Right Hand
30"	1310026	1310062
36"	1410026	1410062
42"	1810026	1810062
48"	1510026	1510062
1000mm	1710026	1710062

- Left hand Door/Drawer Unit shown.
- Right hand Door/Drawer Units are reverse of what is shown.



*STEEL CASEWORK  
BASE CABINETS - STANDING HEIGHT*

**Door/Drawer Units**



Width	Left Hand	Right Hand
30"	1310027	1310072
36"	1410027	1410072
42"	1810027	1810072
48"	1510027	1510072
1000mm	1710027	1710072

- Left hand Door/Drawer Unit shown.
- Right hand Door/Drawer Units are reverse of what is shown.



Width	Left Hand	Right Hand
30"	1310028	1310082
36"	1410028	1410082
42"	1810028	1810082
48"	1510028	1510082
1000mm	1710028	1710082

- Left hand Door/Drawer Unit shown.
- Right hand Door/Drawer Units are reverse of what is shown.
- If locks are required, the lowest drawer of the cabinet will require a slot in the bottom of the drawer body to accommodate the lock cam.



Width	Left Hand	Right Hand
30"	1310034	1310043
36"	1410034	1410043
42"	1810034	1810043
48"	1510034	1510043
1000mm	1710034	1710043

- Left hand Door/Drawer Unit shown.
- Right hand Door/Drawer Units are reverse of what is shown.



Width	Left Hand	Right Hand
30"	1310035	1310053
36"	1410035	1410053
42"	1810035	1810053
48"	1510035	1510053
1000mm	1710035	1710053

- Left hand Door/Drawer Unit shown.
- Right hand Door/Drawer Units are reverse of what is shown.



Width	Left Hand	Right Hand
30"	1310036	1310063
36"	1410036	1410063
42"	1810036	1810063
48"	1510036	1510063
1000mm	1710036	1710063

- Left hand Door/Drawer Unit shown.
- Right hand Door/Drawer Units are reverse of what is shown.



*STEEL CASEWORK  
BASE CABINETS - STANDING HEIGHT*

**Door/Drawer Units**

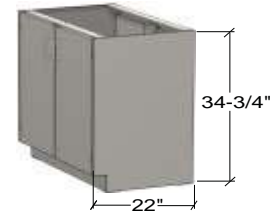

Width	Left Hand	Right Hand
30"	1310037	1310073
36"	1410037	1410073
42"	1810037	1810073
48"	1510037	1510073
1000mm	1710037	1710073

- Left hand Door/Drawer Unit shown.
- Right hand Door/Drawer Units are reverse of what is shown.



Width	Left Hand	Right Hand
30"	1310038	1310083
36"	1410038	1410083
42"	1810038	1810083
48"	1510038	1510083
1000mm	1710038	1710083

- Left hand Door/Drawer Unit shown.
- Right hand Door/Drawer Units are reverse of what is shown.
- If locks are required, the lowest drawer of the cabinet will require a slot in the bottom of the drawer body to accommodate the lock cam.

**Drawer Units**



up to 24" wide



30" and wider

Width	Item Number
12"	1010090
15"	1910090
18"	1110090
24"	1210090
30"	13100NN
36"	14100NN
42"	18100NN
48"	15100NN
513mm	1610090
1000mm	17100NN



up to 24" wide



30" and wider

Width	Item Number
12"	1010044
15"	1910044
18"	1110044
24"	1210044
30"	1310044
36"	1410044
42"	1810044
48"	1510044
513mm	1610044
1000mm	1710044

*STEEL CASEWORK  
BASE CABINETS - STANDING HEIGHT*

**Drawer Units**



up to 24" wide



30" and wider

Width	Item Number
15"	1910055
18"	1110055
24"	1210055
30"	1310055
36"	1410055
42"	1810055
48"	1510055
513mm	1610055
1000mm	1710055



up to 24" wide



30" and wider

Width	Item Number
15"	1910066
18"	1110066
24"	1210066
30"	1310066
36"	1410066
42"	1810066
48"	1510066
513mm	1610066
1000mm	1710066



up to 24" wide



30" and wider

Width	Item Number
15"	1910077
18"	1110077
24"	1210077
30"	1310077
36"	1410077
42"	1810077
48"	1510077
513mm	1610077
1000mm	1710077



up to 24" wide



30" and wider

Width	Item Number
15"	1910088
18"	1110088
24"	1210088
30"	1310088
36"	1410088
42"	1810088
48"	1510088
513mm	1610088
1000mm	1710088

- If locks are required, the lowest drawers of the cabinet will require a slot in the bottom of the drawer body to accommodate the lock cam.



up to 24" wide



30" and wider

Width	Item Number
15"	19100BB
18"	11100BB
24"	12100BB
30"	13100BB
36"	14100BB
42"	18100BB
48"	15100BB
513mm	16100BB
1000mm	17100BB

All dimensions and sizes shown are nominal. Specifications and details are based on product information at the time of printing and may change at any time without notice. Mott Manufacturing reserves the right to change dimensions, specifications and manufacturing details at any time without notice.

*STEEL CASEWORK  
BASE CABINETS - STANDING HEIGHT*

**Drawer Units**

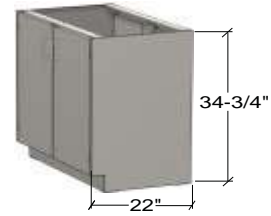

Width	Item Number
30"	1310A91
36"	1410A91
42"	1810A91
48"	1510A91
1000mm	1710A91



Width	Item Number
30"	1310090
36"	1410090
42"	1810090
48"	1510090
1000mm	1710090



Width	Item Number
30"	1310097
36"	1410097
42"	1810097
48"	1510097
1000mm	1710097



Width	Item Number
30"	1310098
36"	1410098
42"	1810098
48"	1510098
1000mm	1710098



Width	Item Number
30"	1310091
36"	1410091
42"	1810091
48"	1510091
1000mm	1710091

*STEEL CASEWORK  
BASE CABINETS - STANDING HEIGHT*

**Drawer Units**



Width	Item Number
30"	1310099
36"	1410099
42"	1810099
48"	1510099
1000mm	1710099



Width	Item Number
30"	1310B44
36"	1410B44
42"	1810B44
48"	1510B44
1000mm	1710B44



Width	Item Number
30"	1310094
36"	1410094
42"	1810094
48"	1510094
1000mm	1710094



Width	Item Number
30"	1310092
36"	1410092
42"	1810092
48"	1510092
1000mm	1710092



Width	Item Number
30"	1310095
36"	1410095
42"	1810095
48"	1510095
1000mm	1710095

*STEEL CASEWORK  
BASE CABINETS - STANDING HEIGHT*

**Drawer Units**



Width	Left Hand	Right Hand
30"	1310029	1310019
36"	1410029	1410019
42"	1810029	1810019
48"	1510029	1510019
1000mm	1710029	1710019

- Left hand Drawer Unit shown.
- Right hand Drawer Units are reverse of what is shown.



Width	Item Number
30"	1310039
36"	1410039
42"	1810039
48"	1510039
1000mm	1710039



Width	Item Number
30"	13100CC
36"	14100CC
42"	18100CC
48"	15100CC
1000mm	17100CC

**File Drawer Units**



up to 24" wide



30" and wider

Width	Item Number
12"	1010133
15"	1910133
18"	1110133
24"	1210133
30"	1310133
36"	1410133
42"	1810133
48"	1510133
513mm	1610133
1000mm	1710133

*STEEL CASEWORK  
BASE CABINETS - STANDING HEIGHT*

**File Drawer Units**



up to 24" wide



30" and wider

Width	Item Number
15"	1910100
18"	1110100
24"	1210100
30"	1310100
36"	1410100
42"	1810100
48"	1510100
513mm	1610100
1000mm	1710100



up to 24" wide



30" and wider

Width	Item Number
15"	1910111
18"	1110111
24"	1210111
30"	1310111
36"	1410111
42"	1810111
48"	1510111
513mm	1610111
1000mm	1710111



up to 24" wide



30" and wider

Width	Item Number
15"	1910122
18"	1110122
24"	1210122
30"	1310122
36"	1410122
42"	1810122
48"	1510122
513mm	1610122
1000mm	1710122



up to 24" wide



30" and wider

Width	Item Number
15"	19101AA
18"	11101AA
24"	12101AA
30"	13101AA
36"	14101AA
42"	18101AA
48"	15101AA
513mm	16101AA
1000mm	17101AA

All dimensions and sizes shown are nominal. Specifications and details are based on product information at the time of printing and may change at any time without notice. Mott Manufacturing reserves the right to change dimensions, specifications and manufacturing details at any time without notice.



*STEEL CASEWORK  
BASE CABINETS - STANDING HEIGHT*

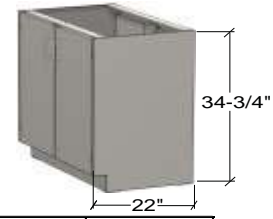

**Control Panel Units**



up to 24" wide



30" and wider

Width	Right Hinged	Left Hinged	# of Doors
12"	1015022	1015222	1
15"	1915022	1915222	1
18"	1115022	1115222	1
24"	1215022	1215222	1
30"	1315022	-	2
36"	1415022	-	2
42"	1815022	-	2
48"	1515022	-	2
513mm	1615022	1615222	1
1000mm	1715022	-	2

**Sliding Door Units**



Width	Item Number
30"	1310711
36"	1410711
42"	1810711
48"	1510711
1000mm	1710711

**Waste/Storage Bin Units**



up to 24" wide



30" and wider

Width	Item Number	# of Bins
15"	1910500	1
18"	1110500	1
24"	1210500	1
30"	1310500	2
36"	1410500	2
42"	1810500	2
48"	1510500	2
513mm	1610500	1
1000mm	1710500	2

- Galvanized bin insert is not included with Waste/Storage Bin Units.
- Tilt out door is hinged at the bottom.

**Corner Units**

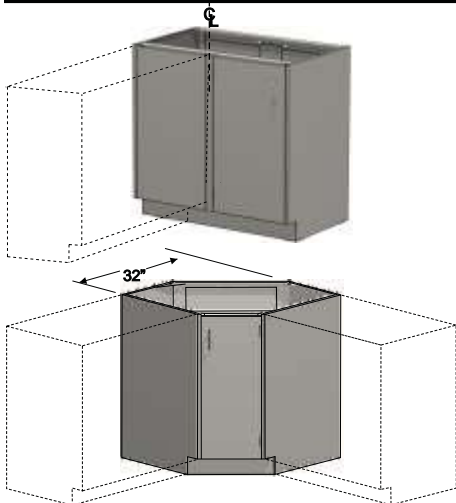

Width	Door On Right	Door On Left
30"	1310311	1310411
36"	1410311	1410411
42"	1810311	1810411
48"	1510311	1510411
1000mm	1710311	1710411

- Right Door Corner Unit shown.
- Left Door Corner Units are reverse of what is shown.
- Center style is located at the middle point.

Description	Right Hinged	Left Hinged
Full Door Unit	1017011	1017111
False Panel Unit	1017422	1017922

- Right hinge, Full Door Corner Unit shown.
- Overall depth of this unit is 26" from the front of the door to the back of the cabinet.
- Add Option Code 89 to order a Lazy Susan.



*STEEL CASEWORK  
BASE CABINETS - SITTING HEIGHT*

**Open Units**

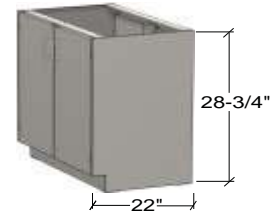

Width	Item Number
15"	1920000
18"	1120000
24"	1220000
30"	1320000
36"	1420000
42"	1820000
48"	1520000
513mm	1620000
1000mm	1720000

**Full Door Units**



up to 24" wide



30" and wider

Width	Right Hinged	Left Hinged	# of Doors
12"	1020011	1020211	1
15"	1920011	1920211	1
18"	1120011	1120211	1
24"	1220011	1220211	1
30"	1320011	-	2
36"	1420011	-	2
42"	1820011	-	2
48"	1520011	-	2
513mm	1620011	1620211	1
1000mm	1720011	-	2

**Door/Drawer Units**



up to 24" wide



30" and wider

Width	Right Hinged	Left Hinged	# of Doors
12"	1020022	1020222	1
15"	1920022	1920222	1
18"	1120022	1120222	1
24"	1220022	1220222	1
30"	1320022	-	2
36"	1420022	-	2
42"	1820022	-	2
48"	1520022	-	2
513mm	1620022	1620222	1
1000mm	1720022	-	2



up to 24" wide



30" and wider

Width	Right Hinged	Left Hinged	# of Doors
15"	1920033	1920233	1
18"	1120033	1120233	1
24"	1220033	1220233	1
30"	1320033	-	2
36"	1420033	-	2
42"	1820033	-	2
48"	1520033	-	2
513mm	1620033	1620233	1
1000mm	1720033	-	2

*STEEL CASEWORK  
BASE CABINETS - SITTING HEIGHT*

**Door/Drawer Units**

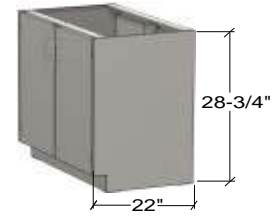

Width	Item Number
30"	1320093
36"	1420093
42"	1820093
48"	1520093
1000mm	1720093



Width	Item Number
30"	1320096
36"	1420096
42"	1820096
48"	1520096
1000mm	1720096



Width	Left Hand	Right Hand
30"	1320023	1320032
36"	1420023	1420032
42"	1820023	1820032
48"	1520023	1520032
1000mm	1720023	1720032

- Left hand Door/Drawer Unit shown.
- Right hand Door/Drawer Units are reverse of what is shown.



Width	Left Hand	Right Hand
30"	1320012	1320021
36"	1420012	1420021
42"	1820012	1820021
48"	1520012	1520021
1000mm	1720012	1720021

- Left hand Door/Drawer Unit shown.
- Right hand Door/Drawer Units are reverse of what is shown.



Width	Left Hand	Right Hand
30"	1320013	1320031
36"	1420013	1420031
42"	1820013	1820031
48"	1520013	1520031
1000mm	1720013	1720031

- Left hand Door/Drawer Unit shown.
- Right hand Door/Drawer Units are reverse of what is shown.

*STEEL CASEWORK  
BASE CABINETS - SITTING HEIGHT*

**Door/Drawer Units**

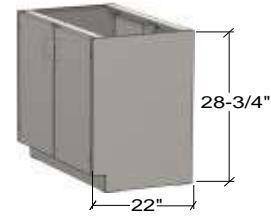

Width	Left Hand	Right Hand
30"	1320014	1320041
36"	1420014	1420041
42"	1820014	1820041
48"	1520014	1520041
1000mm	1720014	1720041

- Left hand Door/Drawer Unit shown.
- Right hand Door/Drawer Units are reverse of what is shown.



Width	Left Hand	Right Hand
30"	1320015	1320051
36"	1420015	1420051
42"	1820015	1820051
48"	1520015	1520051
1000mm	1720015	1720051

- Left hand Door/Drawer Unit shown.
- Right hand Door/Drawer Units are reverse of what is shown.



Width	Left Hand	Right Hand
30"	1320016	1320061
36"	1420016	1420061
42"	1820016	1820061
48"	1520016	1520061
1000mm	1720016	1720061

- Left hand Door/Drawer Unit shown.
- Right hand Door/Drawer Units are reverse of what is shown.



Width	Left Hand	Right Hand
30"	1320924	1320942
36"	1420924	1420942
42"	1820924	1820942
48"	1520924	1520942
1000mm	1720924	1720942

- Left hand Door/Drawer Unit shown.
- Right hand Door/Drawer Units are reverse of what is shown.



Width	Left Hand	Right Hand
30"	1320024	1320042
36"	1420024	1420042
42"	1820024	1820042
48"	1520024	1520042
1000mm	1720024	1720042

- Left hand Door/Drawer Unit shown.
- Right hand Door/Drawer Units are reverse of what is shown.

*STEEL CASEWORK  
BASE CABINETS - SITTING HEIGHT*

**Door/Drawer Units**

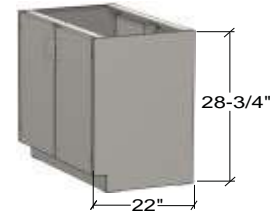

Width	Left Hand	Right Hand
30"	1320025	1320052
36"	1420025	1420052
42"	1820025	1820052
48"	1520025	1520052
1000mm	1720025	1720052

- Left hand Door/Drawer Unit shown.
- Right hand Drawer Units are reverse of what is shown.



Width	Left Hand	Right Hand
30"	1320026	1320062
36"	1420026	1420062
42"	1820026	1820062
48"	1520026	1520062
1000mm	1720026	1720062

- Left hand Door/Drawer Unit shown.
- Right hand Door/Drawer Units are reverse of what is shown.



Width	Left Hand	Right Hand
30"	1320027	1320072
36"	1420027	1420072
42"	1820027	1820072
48"	1520027	1520072
1000mm	1720027	1720072

- Left hand Door/Drawer Unit shown.
- Right hand Door/Drawer Units are reverse of what is shown.



Width	Left Hand	Right Hand
30"	1320034	1320043
36"	1420034	1420043
42"	1820034	1820043
48"	1520034	1520043
1000mm	1720034	1720043

- Left hand Door/Drawer Unit shown.
- Right hand Door/Drawer Units are reverse of what is shown.



Width	Left Hand	Right Hand
30"	1320035	1320053
36"	1420035	1420053
42"	1820035	1820053
48"	1520035	1520053
1000mm	1720035	1720053

- Left hand Door/Drawer Unit shown.
- Right hand Door/Drawer Units are reverse of what is shown.

*STEEL CASEWORK  
BASE CABINETS - SITTING HEIGHT*

**Door/Drawer Units**

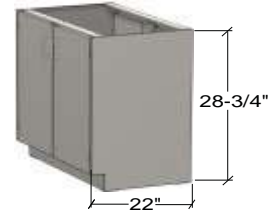

Width	Left Hand	Right Hand
30"	1320036	1320063
36"	1420036	1420063
42"	1820036	1820063
48"	1520036	1520063
1000mm	1720036	1720063

- Left hand Door/Drawer Unit shown.
- Right hand Door/Drawer Units are reverse of what is shown.



Width	Left Hand	Right Hand
30"	1320037	1320073
36"	1420037	1420073
42"	1820037	1820073
48"	1520037	1520073
1000mm	1720037	1720073

- Left hand Door/Drawer Unit shown.
- Right hand Door/Drawer Units are reverse of what is shown.

**Drawer Units**



up to 24" wide



30" and wider

Width	Item Number
15"	1920044
18"	1120044
24"	1220044
30"	1320044
36"	1420044
42"	1820044
48"	1520044
513mm	1620044
1000mm	1720044



up to 24" wide



30" and wider

Width	Item Number
15"	19200MM
18"	11200MM
24"	12200MM
30"	13200MM
36"	14200MM
42"	18200MM
48"	15200MM
513mm	16200MM
1000mm	17200MM

*STEEL CASEWORK  
BASE CABINETS - SITTING HEIGHT*

**Drawer Units**

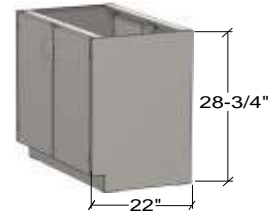

up to 24" wide



30" and wider

Width	Item Number
15"	1920055
18"	1120055
24"	1220055
30"	1320055
36"	1420055
42"	1820055
48"	1520055
513mm	1620055
1000mm	1720055



up to 24" wide



30" and wider

Width	Item Number
15"	1920066
18"	1120066
24"	1220066
30"	1320066
36"	1420066
42"	1820066
48"	1520066
513mm	1620066
1000mm	1720066



up to 24" wide



30" and wider

Width	Item Number
15"	1920077
18"	1120077
24"	1220077
30"	1320077
36"	1420077
42"	1820077
48"	1520077
513mm	1620077
1000mm	1720077

- If locks are required, the lowest drawers of the cabinet will require a slot in the bottom of the drawer body to accommodate the lock cam.



Width	Item Number
30"	1320097
36"	1420097
42"	1820097
48"	1520097
1000mm	1720097



Width	Item Number
30"	13200LL
36"	14200LL
42"	18200LL
48"	15200LL
1000mm	17200LL

*STEEL CASEWORK  
BASE CABINETS - SITTING HEIGHT*

**Drawer Units**



Width	Item Number
30"	1320098
36"	1420098
42"	1820098
48"	1520098
1000mm	1720098



Width	Item Number
30"	1320091
36"	1420091
42"	1820091
48"	1520091
1000mm	1720091



Width	Item Number
30"	1320099
36"	1420099
42"	1820099
48"	1520099
1000mm	1720099



Width	Item Number
30"	1320094
36"	1420094
42"	1820094
48"	1520094
1000mm	1720094



Width	Item Number
30"	1320092
36"	1420092
42"	1820092
48"	1520092
1000mm	1720092



Width	Item Number
30"	1320095
36"	1420095
42"	1820095
48"	1520095
1000mm	1720095



*STEEL CASEWORK  
BASE CABINETS - SITTING HEIGHT*

**Drawer Units**

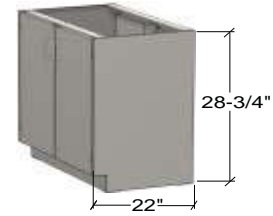

Width	Item Number
30"	1320B44
36"	1420B44
42"	1820B44
48"	1520B44
1000mm	1720B44

**File Drawer Units**



up to 24" wide



30" and wider

Width	Item Number
15"	1920122
18"	1120122
24"	1220122
30"	1320122
36"	1420122
42"	1820122
48"	1520122
513mm	1620122
1000mm	1720122



up to 24" wide



30" and wider

Width	Item Number
15"	1920177
18"	1120177
24"	1220177
30"	1320177
36"	1420177
42"	1820177
48"	1520177
513mm	1620177
1000mm	1720177



up to 24" wide



30" and wider

Width	Item Number
15"	1920188
18"	1120188
24"	1220188
30"	1320188
36"	1420188
42"	1820188
48"	1520188
513mm	1620188
1000mm	1720188

*STEEL CASEWORK  
BASE CABINETS - SITTING HEIGHT*

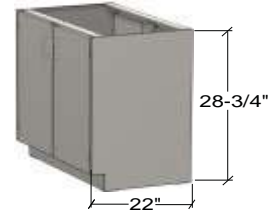

**Control Panel Units**



up to 24" wide



30" and wider

Width	Right Hinged	Left Hinged	# of Doors
12"	1025022	1025222	1
15"	1925022	1925222	1
18"	1125022	1125222	1
24"	1225022	1225222	1
30"	1325022	-	2
36"	1425022	-	2
42"	1825022	-	2
48"	1525022	-	2
513mm	1625022	1625222	1
1000mm	1725022	-	2

**Sliding Door Units**



Width	Item Number
30"	1320711
36"	1420711
42"	1820711
48"	1520711
1000mm	1720711

**Waste/Storage Bin Units**



up to 24" wide



30" and wider

Width	Item Number	# of Bins
15"	1920500	1
18"	1120500	1
24"	1220500	1
30"	1320500	2
36"	1420500	2
42"	1820500	2
48"	1520500	2
513mm	1620500	1
1000mm	1720500	2

- Galvanized bin insert is not included with Waste/Storage Bin Units.
- Tilt out door is hinged at the bottom.

**Corner Units**

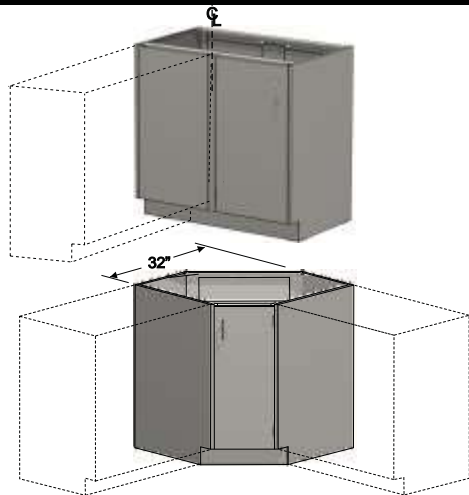

Width	Door On Right	Door On Left
30"	1320311	1320411
36"	1420311	1420411
42"	1820311	1820411
48"	1520311	1520411
1000mm	1720311	1720411

- Right Door Corner Unit shown.
- Left Door Corner Units are reverse of what is shown.
- Center style is located at the middle point.

Description	Right Hinged	Left Hinged
Full Door Unit	1027011	1027111
False Panel Unit	1027422	1027922

- Right hinge, Full Door Corner Unit shown.
- Overall depth of this unit is 26" from the front of the door to the back of the cabinet.
- Add Option Code 89 to order a Lazy Susan.

*STEEL CASEWORK  
BASE CABINETS - ADA HEIGHT*

**Open Units**



Width	Item Number
15"	1980000
18"	1180000
24"	1280000
30"	1380000
36"	1480000
42"	1880000
48"	1580000
513mm	1680000
1000mm	1780000

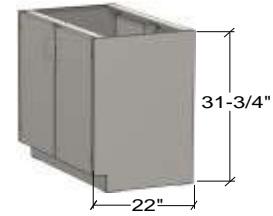

**Full Door Units**



up to 24" wide



30" and wider

Width	Right Hinged	Left Hinged	# of Doors
12"	1080011	1080211	1
15"	1980011	1980211	1
18"	1180011	1180211	1
24"	1280011	1280211	1
30"	1380011	-	2
36"	1480011	-	2
42"	1880011	-	2
48"	1580011	-	2
513mm	1680011	1680211	1
1000mm	1780011	-	2

**Door/Drawer Units**



up to 24" wide



30" and wider

Width	Right Hinged	Left Hinged	# of Doors
12"	1080022	1080222	1
15"	1980022	1980222	1
18"	1180022	1180222	1
24"	1280022	1280222	1
30"	1380022	-	2
36"	1480022	-	2
42"	1880022	-	2
48"	1580022	-	2
513mm	1680022	1680222	1
1000mm	1780022	-	2



Width	Left Hand	Right Hand
30"	1380924	1380942
36"	1480924	1480942
42"	1880924	1880942
48"	1580924	1580942
1000mm	1780924	1780942

- Left hand Door/Drawer Unit shown.
- Right hand Door/Drawer Units are reverse of what is shown.



Width	Left Hand	Right Hand
30"	1380024	1380042
36"	1480024	1480042
42"	1880024	1880042
48"	1580024	1580042
1000mm	1780024	1780042

- Left hand Door/Drawer Unit shown.
- Right hand Door/Drawer Units are reverse of what is shown.

*STEEL CASEWORK  
BASE CABINETS - ADA HEIGHT*

**Drawer Units**

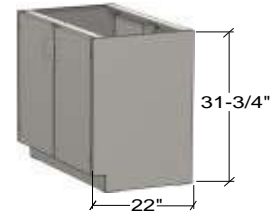

up to 24" wide



30" and wider

Width	Item Number
15"	1980090
18"	1180090
24"	1280090
30"	13800NN
36"	14800NN
42"	18800NN
48"	15800NN
513mm	1680090
1000mm	17800NN



up to 24" wide



30" and wider

Width	Item Number
12"	1080044
15"	1980044
18"	1180044
24"	1280044
30"	1380044
36"	1480044
42"	1880044
48"	1580044
513mm	1680044
1000mm	1780044



up to 24" wide



30" and wider

Width	Item Number
15"	1980055
18"	1180055
24"	1280055
30"	1380055
36"	1480055
42"	1880055
48"	1580055
513mm	1680055
1000mm	1780055



Width	Item Number
30"	1380090
36"	1480090
42"	1880090
48"	1580090
1000mm	1780090



Width	Item Number
30"	1380097
36"	1480097
42"	1880097
48"	1580097
1000mm	1780097

*STEEL CASEWORK  
BASE CABINETS - ADA HEIGHT*

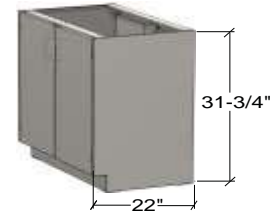

**Drawer Units**



Width	Item Number
30"	1380099
36"	1480099
42"	1880099
48"	1580099
1000mm	1780099

**File Drawer Units**



up to 24" wide



30" and wider

Width	Item Number
15"	1980100
18"	1180100
24"	1280100
30"	1380100
36"	1480100
42"	1880100
48"	1580100
513mm	1680100
1000mm	1780100



up to 24" wide



30" and wider

Width	Item Number
15"	1980111
18"	1180111
24"	1280111
30"	1380111
36"	1480111
42"	1880111
48"	1580111
513mm	1680111
1000mm	1780111

**Control Panel Units**



up to 24" wide



30" and wider

Width	Right Hinged	Left Hinged	# of Doors
12"	1085022	1085222	1
15"	1985022	1985222	1
18"	1185022	1185222	1
24"	1285022	1285222	1
30"	1385022	-	2
36"	1485022	-	2
42"	1885022	-	2
48"	1585022	-	2
513mm	1685022	1685222	1
1000mm	1785022	-	2

**Sliding Door Units**



Width	Item Number
30"	1380711
36"	1480711
42"	1880711
48"	1580711
1000mm	1780711

*STEEL CASEWORK  
BASE CABINETS - STANDING HEIGHT*

**Sink Units**



up to 24" wide



30" and wider

Width	Right Hinged	Left Hinged	# of Doors
12"	1013011	1013211	1
15"	1913011	1913211	1
18"	1113011	1113211	1
24"	1213011	1213211	1
30"	1313011	-	2
36"	1413011	-	2
42"	1813011	-	2
48"	1513011	-	2
513mm	1613011	1613211	1
1000mm	1713011	-	2

- Add Option Code 90 to order Sink Hanger Supports.



up to 24" wide



30" and wider

Width	Right Hinged	Left Hinged	# of Doors
12"	1018022	1018222	1
15"	1918022	1918222	1
18"	1118022	1118222	1
24"	1218022	1218222	1
30"	1318022	-	2
36"	1418022	-	2
42"	1818022	-	2
48"	1518022	-	2
513mm	1618022	1618222	1
1000mm	1718022	-	2

- Add Option Code 90 to order Sink Hanger Supports.

**End Sink Units**



Description	54" Wide	58" Wide
Full Door Unit	9900017	9900018
False Panel Unit	9900021	9900022

- Full Door End Sink Unit shown.
- Add Option Code 90 to order Sink Hanger Supports.

**Corner Sink Units**

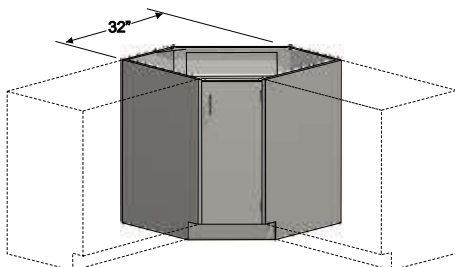

Description	Right Hinged	Left Hinged
Full Door Unit	1017211	1017511
False Panel Unit	1017722	1017622

- Right hinge, Full Door Corner Sink Unit shown.
- Overall depth of this unit is 26" from the front of the door to the back of the cabinet.
- Add Option Code 90 to order Sink Hanger Supports.

*STEEL CASEWORK  
BASE CABINETS - SITTING HEIGHT*

**Sink Units**

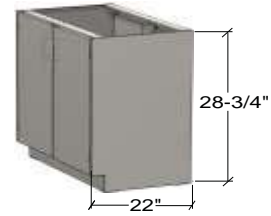

up to 24" wide



30" and wider

Width	Right Hinged	Left Hinged	# of Doors
12"	1023011	1023211	1
15"	1923011	1923211	1
18"	1123011	1123211	1
24"	1223011	1223211	1
30"	1323011	-	2
36"	1423011	-	2
42"	1823011	-	2
48"	1523011	-	2
513mm	1623011	1623211	1
1000mm	1723011	-	2

- Add Option Code 90 to order Sink Hanger Supports.



up to 24" wide



30" and wider

Width	Right Hinged	Left Hinged	# of Doors
12"	1028022	1028222	1
15"	1928022	1928222	1
18"	1128022	1128222	1
24"	1228022	1228222	1
30"	1328022	-	2
36"	1428022	-	2
42"	1828022	-	2
48"	1528022	-	2
513mm	1628022	1628222	1
1000mm	1728022	-	2

- Add Option Code 90 to order Sink Hanger Supports.

**End Sink Units**



Description	54" Wide	58" Wide
Full Door Unit	9900019	9900020
False Panel Unit	9900023	9900024

- Full Door End Sink Unit shown.
- Add Option Code 90 to order Sink Hanger Supports.

**Sink Support Kit**



Width	Cabinet Depth	Cabinet Depth
	18"D	22"D
12"	SSK0012	SSK1012
15"	SSK0015	SSK1015
18"	SSK0018	SSK1018
24"	SSK0024	SSK1024
30"	SSK0030	SSK1030
36"	SSK0036	SSK1036
42"	SSK0042	SSK1042
48"	SSK0048	SSK1048
54"	SSK0054	SSK1054
58"	SSK0058	SSK1058

Description	26"D
Corner Unit	SSK0000

- Metal frame to support and position an under mount sink.
- Sink Support Kit for Corner Unit not exactly as shown.



### STEEL CASEWORK BASE CABINETS - ADA HEIGHT

#### Sink Units

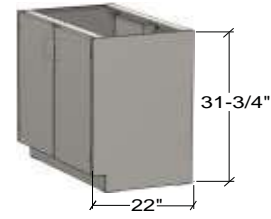

up to 24" wide



30" and wider

Width	Right Hinged	Left Hinged	# of Doors
12"	1083011	1083211	1
15"	1983011	1983211	1
18"	1183011	1183211	1
24"	1283011	1283211	1
30"	1383011	-	2
36"	1483011	-	2
42"	1883011	-	2
48"	1583011	-	2
513mm	1683011	1683211	1
1000mm	1783011		2

- Add Option Code 90 to order Sink Hanger Supports.



up to 24" wide



30" and wider

Width	Right Hinged	Left Hinged	# of Doors
12"	1088022	1088222	1
15"	1988022	1988222	1
18"	1188022	1188222	1
24"	1288022	1288222	1
30"	1388022	-	2
36"	1488022	-	2
42"	1888022	-	2
48"	1588022	-	2
513mm	1688022	1688222	1
1000mm	1788022	-	2

- Add Option Code 90 to order Sink Hanger Supports.

#### Pocket Door Sink Units



Base bottom in down position



Base bottom in knee space position

Width	Item Number
30"	138KS22
36"	148KS22
42"	188KS22
48"	158KS22
1000mm	178KS22

- Incorporates pocket doors and fold-up base to convert from sink cabinet design to knee space design.

#### End Sink Units



Description	54" Wide	58" Wide
Full Door Unit	9980017	9980018
False Panel Unit	9980021	9980022

- Full Door End Sink Unit shown.
- Add Option Code 90 to order Sink Hanger Supports.

#### Corner Sink Units

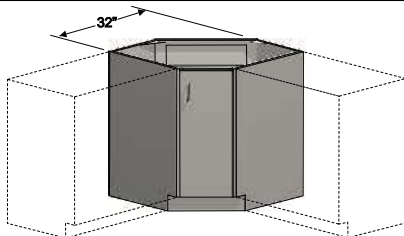

Description	Right Hinged	Left Hinged
Full Door Unit	1087211	1087511
False Panel Unit	1087722	1087622

- Right hinge, Full Door Corner Sink Unit shown.
- Overall depth of this unit is 26" from the front of the door to the back of the cabinet.
- Add Option Code 90 to order Sink Hanger Supports.

*STEEL CASEWORK  
BASE CABINETS - ADA HEIGHT*

**Knee Space Sink Units**

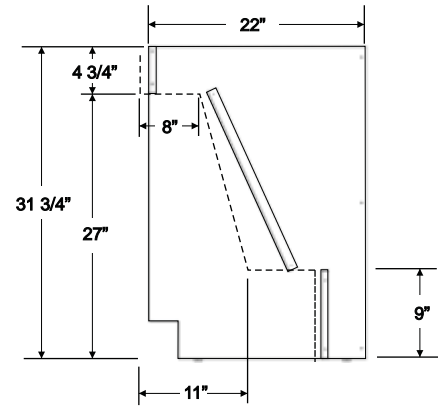
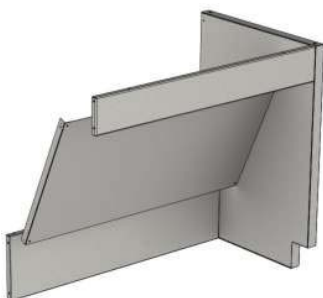

Note: Dotted line represents ADA requirements.

Knee Space Sink Cabinet	
Width	Item Number
30"	13K3011
36"	13K3311
36"	14K3011
42"	18K3011
48"	15K3011
1000mm	17K3011

- Gable Legs are 1-1/2" wide on this unit.
- Knee Space ships unassembled.
- Accommodates a 6" deep sink.
- 30" wide cabinets are not ADA compliant.

Center Panel Only	
Width	Item Number
30"	13KP011
36"	14KP011
42"	18KP011
48"	15KP011
1000mm	17KP011

- Knee Space ships unassembled.
- Accommodates a 6" deep sink.

Left Leg With Center Panel	
Width	Item Number
30"	13KL011
36"	14KL011
42"	18KL011
48"	15KL011
1000mm	17KL011

- Gable Legs are 1-1/2" wide on this unit.
- Knee Space ships unassembled.
- Accommodates a 6" deep sink.
- 30" wide cabinets are not ADA compliant.

Right Leg With Center Panel	
Width	Item Number
30"	13KR011
36"	14KR011
42"	18KR011
48"	15KR011
1000mm	17KR011

- Gable Legs are 1-1/2" wide on this unit.
- Knee Space ships unassembled.
- Accommodates a 6" deep sink.
- 30" wide cabinets are not ADA compliant.

*STEEL CASEWORK  
WALL CABINETS*

**Open Units**

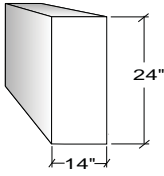

Width	Item Number
15"	5770010
18"	5170010
24"	5270010
30"	5370010
36"	5470010
42"	5670010
48"	5570010
513mm	5970010
1000mm	5870010

**Hinged Framed Door Units**



up to 24" wide



30" and wider

Width	Right Hinged	Left Hinged	# of Doors
15"	5770030	5771030	1
18"	5170030	5171030	1
24"	5270030	5271030	1
30"	5370030	-	2
36"	5470030	-	2
42"	5670030	-	2
48"	5570030	-	2
513mm	5970030	5971030	1
1000mm	5870030	-	2

**Hinged Door Units**



up to 24" wide



30" and wider

Width	Right Hinged	Left Hinged	# of Doors
15"	5770060	5771060	1
18"	5170060	5171060	1
24"	5270060	5271060	1
30"	5370060	-	2
36"	5470060	-	2
42"	5670060	-	2
48"	5570060	-	2
513mm	5970060	5971060	1
1000mm	5870060	-	2

**Sliding Glass Door Units**



Width	Item Number
30"	5370020
36"	5470020
42"	5670020
48"	5570020
1000mm	5870020

*STEEL CASEWORK  
WALL CABINETS*

**Sliding Framed Door Units**

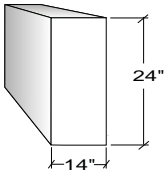

Width	Item Number
30"	5370040
36"	5470040
42"	5670040
48"	5570040
1000mm	5870040

**Sliding Door Units**



Width	Item Number
30"	5370050
36"	5470050
42"	5670050
48"	5570050
1000mm	5870050

*BLIND CORNER WALL CABINETS*

**Hinged Framed Door Units**



Width	Door On Right	Door On Left
30"	5370330	5370430
36"	5470330	5470430
42"	5670330	5670430
48"	5570330	5570430
1000mm	5870330	5870430

- Right Door Blind Corner Unit shown.
- Left Door Blind Corner Units are reverse of what is shown.
- Blind portion of cabinet is 14" wide on these units.

**Hinged Door Units**



Width	Door On Right	Door On Left
30"	5370360	5370460
36"	5470360	5470460
42"	5670360	5670460
48"	5570360	5570460
1000mm	5870360	5870460

- Right Door Blind Corner Unit shown.
- Left Door Blind Corner Units are reverse of what is shown.
- Blind portion of cabinet is 14" wide on these units.

*STEEL CASEWORK  
WALL CABINETS*

**Open Units**

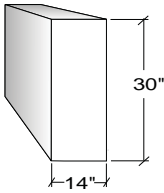

Width	Item Number
15"	5710010
18"	5110010
24"	5210010
30"	5310010
36"	5410010
42"	5610010
48"	5510010
513mm	5910010
1000mm	5810010

**Hinged Framed Door Units**



up to 24" wide



30" and wider

Width	Right Hinged	Left Hinged	# of Doors
15"	5710030	5711030	1
18"	5110030	5111030	1
24"	5210030	5211030	1
30"	5310030	-	2
36"	5410030	-	2
42"	5610030	-	2
48"	5510030	-	2
513mm	5910030	5911030	1
1000mm	5810030	-	2

**Hinged Door Units**



up to 24" wide



30" and wider

Width	Right Hinged	Left Hinged	# of Doors
15"	5710060	5711060	1
18"	5110060	5111060	1
24"	5210060	5211060	1
30"	5310060	-	2
36"	5410060	-	2
42"	5610060	-	2
48"	5510060	-	2
513mm	5910060	5911060	1
1000mm	5810060	-	2

**Sliding Glass Door Units**



Width	Item Number
30"	5310020
36"	5410020
42"	5610020
48"	5510020
1000mm	5810020

*STEEL CASEWORK  
WALL CABINETS*

**Sliding Framed Door Units**

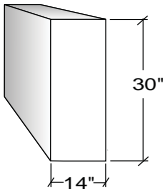

Width	Item Number
30"	5310040
36"	5410040
42"	5610040
48"	5510040
1000mm	5810040

**Sliding Door Units**



Width	Item Number
30"	5310050
36"	5410050
42"	5610050
48"	5510050
1000mm	5810050

*BLIND CORNER WALL CABINETS*

**Hinged Framed Door Units**



Width	Door On Right	Door On Left
30"	5310330	5310430
36"	5410330	5410430
42"	5610330	5610430
48"	5510330	5510430
1000mm	5810330	5810430

- Right Door Blind Corner Unit shown.
- Left Door Blind Corner Units are reverse of what is shown.
- Blind portion of cabinet is 14" wide on these units.

**Hinged Door Units**



Width	Door On Right	Door On Left
30"	5310360	5310460
36"	5410360	5410460
42"	5610360	5610460
48"	5510360	5510460
1000mm	5810360	5810460

- Right Door Blind Corner Unit shown.
- Left Door Blind Corner Units are reverse of what is shown.
- Blind portion of cabinet is 14" wide on these units.

*STEEL CASEWORK  
WALL CABINETS*

**Open Units**



Width	Item Number
15"	5720010
18"	5120010
24"	5220010
30"	5320010
36"	5420010
42"	5620010
48"	5520010
513mm	5920010
1000mm	5820010

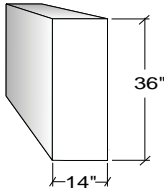

**Hinged Framed Door Units**



up to 24" wide



30" and wider

Width	Right Hinged	Left Hinged	# of Doors
15"	5720030	5721030	1
18"	5120030	5121030	1
24"	5220030	5221030	1
30"	5320030	-	2
36"	5420030	-	2
42"	5620030	-	2
48"	5520030	-	2
513mm	5920030	5921030	1
1000mm	5820030	-	2

**Hinged Door Units**



up to 24" wide



30" and wider

Width	Right Hinged	Left Hinged	# of Doors
15"	5720060	5721060	1
18"	5120060	5121060	1
24"	5220060	5221060	1
30"	5320060	-	2
36"	5420060	-	2
42"	5620060	-	2
48"	5520060	-	2
513mm	5920060	5921060	1
1000mm	5820060	-	2

**Sliding Glass Door Units**



Width	Item Number
30"	5320020
36"	5420020
42"	5620020
48"	5520020
1000mm	5820020



*STEEL CASEWORK  
WALL CABINETS*

**Sliding Framed Door Units**

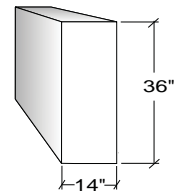

Width	Item Number
30"	5320040
36"	5420040
42"	5620040
48"	5520040
1000mm	5820040

**Sliding Door Units**



Width	Item Number
30"	5320050
36"	5420050
42"	5620050
48"	5520050
1000mm	5820050

*BLIND CORNER WALL CABINETS*

**Hinged Framed Door Units**



Width	Door On Right	Door On Left
30"	5320330	5320430
36"	5420330	5420430
42"	5620330	5620430
48"	5520330	5520430
1000mm	5820330	5820430

- Right Door Blind Corner Unit shown.
- Left Door Blind Corner Units are reverse of what is shown.
- Blind portion of cabinet is 14" wide on these units.

**Hinged Door Units**



Width	Door On Right	Door On Left
30"	5320360	5320460
36"	5420360	5420460
42"	5620360	5620460
48"	5520360	5520460
1000mm	5820360	5820460

- Right Door Blind Corner Unit shown.
- Left Door Blind Corner Units are reverse of what is shown.
- Blind portion of cabinet is 14" wide on these units.

*STEEL CASEWORK  
WALL CABINETS*

**Open Units**



Width	Item Number
15"	5730010
18"	5130010
24"	5230010
30"	5330010
36"	5430010
42"	5630010
48"	5530010
513mm	5930010
1000mm	5830010

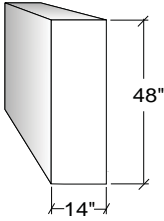

**Hinged Framed Door Units**



up to 24" wide



30" and wider

Width	Right Hinged	Left Hinged	# of Doors
15"	5730030	5731030	1
18"	5130030	5131030	1
24"	5230030	5231030	1
30"	5330030	-	2
36"	5430030	-	2
42"	5630030	-	2
48"	5530030	-	2
513mm	5930030	5931030	1
1000mm	5830030	-	2

**Hinged Door Units**



up to 24" wide



30" and wider

Width	Right Hinged	Left Hinged	# of Doors
15"	5730060	5731060	1
18"	5130060	5131060	1
24"	5230060	5231060	1
30"	5330060	-	2
36"	5430060	-	2
42"	5630060	-	2
48"	5530060	-	2
513mm	5930060	5931060	1
1000mm	5830060	-	2

**Sliding Glass Door Units**



Width	Item Number
30"	5330020
36"	5430020
42"	5630020
48"	5530020
1000mm	5830020

*STEEL CASEWORK  
WALL CABINETS*

**Sliding Framed Door Units**

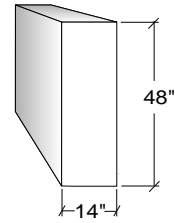

Width	Item Number
30"	5330040
36"	5430040
42"	5630040
48"	5530040
1000mm	5830040

**Sliding Door Units**



Width	Item Number
30"	5330050
36"	5430050
42"	5630050
48"	5530050
1000mm	5830050

*BLIND CORNER WALL CABINETS*

**Hinged Framed Door Units**



Width	Door On Right	Door On Left
30"	5330330	5330430
36"	5430330	5430430
42"	5630330	5630430
48"	5530330	5530430
1000mm	5830330	5830430

- Right Door Blind Corner Unit shown.
- Left Door Blind Corner Units are reverse of what is shown.
- Blind portion of cabinet is 14" wide on these units.

**Hinged Door Units**



Width	Door On Right	Door On Left
30"	5330360	5330460
36"	5430360	5430460
42"	5630360	5630460
48"	5530360	5530460
1000mm	5830360	5830460

- Right Door Blind Corner Unit shown.
- Left Door Blind Corner Units are reverse of what is shown.
- Blind portion of cabinet is 14" wide on these units.

*STEEL CASEWORK  
WALL CABINETS*

**Open Units**

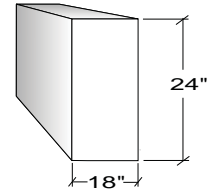

Width	Item Number
15"	5780010
18"	5180010
24"	5280010
30"	5380010
36"	5480010
42"	5680010
48"	5580010
513mm	5980010
1000mm	5880010

**Hinged Framed Door Units**



up to 24" wide



30" and wider

Width	Right Hinged	Left Hinged	# of Doors
15"	5780030	5781030	1
18"	5180030	5181030	1
24"	5280030	5281030	1
30"	5380030	-	2
36"	5480030	-	2
42"	5680030	-	2
48"	5580030	-	2
513mm	5980030	5981030	1
1000mm	5880030	-	2

**Hinged Door Units**



up to 24" wide



30" and wider

Width	Right Hinged	Left Hinged	# of Doors
15"	5780060	5781060	1
18"	5180060	5181060	1
24"	5280060	5281060	1
30"	5380060	-	2
36"	5480060	-	2
42"	5680060	-	2
48"	5580060	-	2
513mm	5980060	5981060	1
1000mm	5880060	-	2

**Sliding Glass Door Units**



Width	Item Number
30"	5380020
36"	5480020
42"	5680020
48"	5580020
1000mm	5880020

*STEEL CASEWORK  
WALL CABINETS*

**Sliding Framed Door Units**

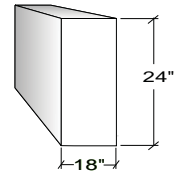

Width	Item Number
30"	5380040
36"	5480040
42"	5680040
48"	5580040
1000mm	5880040

**Sliding Door Units**



Width	Item Number
30"	5380050
36"	5480050
42"	5680050
48"	5580050
1000mm	5880050

*BLIND CORNER WALL CABINETS*

**Hinged Framed Door Units**



Width	Door On Right	Door On Left
30"	5380330	5380430
36"	5480330	5480430
42"	5680330	5680430
48"	5580330	5580430
1000mm	5880330	5880430

- Right Door Blind Corner Unit shown.
- Left Door Blind Corner Units are reverse of what is shown.
- Blind portion of cabinet is 18" wide on these units.

**Hinged Door Units**



Width	Door On Right	Door On Left
30"	5380360	5380460
36"	5480360	5480460
42"	5680360	5680460
48"	5580360	5580460
1000mm	5880360	5880460

- Right Door Blind Corner Unit shown.
- Left Door Blind Corner Units are reverse of what is shown.
- Blind portion of cabinet is 18" wide on these units.

*STEEL CASEWORK  
WALL CABINETS*

**Open Units**



Width	Item Number
15"	5740010
18"	5140010
24"	5240010
30"	5340010
36"	5440010
42"	5640010
48"	5540010
513mm	5940010
1000mm	5840010

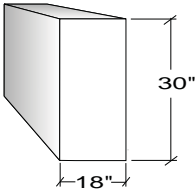

**Hinged Framed Door Units**



up to 24" wide



30" and wider

Width	Right Hinged	Left Hinged	# of Doors
15"	5740030	5741030	1
18"	5140030	5141030	1
24"	5240030	5241030	1
30"	5340030	-	2
36"	5440030	-	2
42"	5640030	-	2
48"	5540030	-	2
513mm	5940030	5941030	1
1000mm	5840030	-	2

**Hinged Door Units**



up to 24" wide



30" and wider

Width	Right Hinged	Left Hinged	# of Doors
15"	5740060	5741060	1
18"	5140060	5141060	1
24"	5240060	5241060	1
30"	5340060	-	2
36"	5440060	-	2
42"	5640060	-	2
48"	5540060	-	2
513mm	5940060	5941060	1
1000mm	5840060	-	2

**Sliding Glass Door Units**



Width	Item Number
30"	5340020
36"	5440020
42"	5640020
48"	5540020
1000mm	5840020

*STEEL CASEWORK  
WALL CABINETS*

**Sliding Framed Door Units**

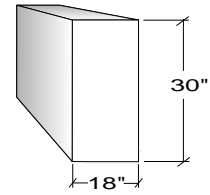

Width	Item Number
30"	5340040
36"	5440040
42"	5640040
48"	5540040
1000mm	5840040

**Sliding Door Units**



Width	Item Number
30"	5340050
36"	5440050
42"	5640050
48"	5540050
1000mm	5840050

*BLIND CORNER WALL CABINETS*

**Hinged Framed Door Units**



Width	Door On Right	Door On Left
30"	5340330	5340430
36"	5440330	5440430
42"	5640330	5640430
48"	5540330	5540430
1000mm	5840330	5840430

- Right Door Blind Corner Unit shown.
- Left Door Blind Corner Units are reverse of what is shown.
- Blind portion of cabinet is 18" wide on these units.

**Hinged Door Units**



Width	Door On Right	Door On Left
30"	5340360	5340460
36"	5440360	5440460
42"	5640360	5640460
48"	5540360	5540460
1000mm	5840360	5840460

- Right Door Blind Corner Unit shown.
- Left Door Blind Corner Units are reverse of what is shown.
- Blind portion of cabinet is 18" wide on these units.



*STEEL CASEWORK  
WALL CABINETS*

**Open Units**

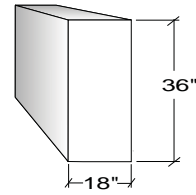

Width	Item Number
15"	5750010
18"	5150010
24"	5250010
30"	5350010
36"	5450010
42"	5650010
48"	5550010
513mm	5950010
1000mm	5850010

**Hinged Framed Door Units**



up to 24" wide



30" and wider

Width	Right Hinged	Left Hinged	# of Doors
15"	5750030	5751030	1
18"	5150030	5151030	1
24"	5250030	5251030	1
30"	5350030	-	2
36"	5450030	-	2
42"	5650030	-	2
48"	5550030	-	2
513mm	5950030	5951030	1
1000mm	5850030	-	2

**Hinged Door Units**



up to 24" wide



30" and wider

Width	Right Hinged	Left Hinged	# of Doors
15"	5750060	5751060	1
18"	5150060	5151060	1
24"	5250060	5251060	1
30"	5350060	-	2
36"	5450060	-	2
42"	5650060	-	2
48"	5550060	-	2
513mm	5950060	5951060	1
1000mm	5850060	-	2

**Sliding Glass Door Units**



Width	Item Number
30"	5350020
36"	5450020
42"	5650020
48"	5550020
1000mm	5850020

*STEEL CASEWORK  
WALL CABINETS*

**Sliding Framed Door Units**

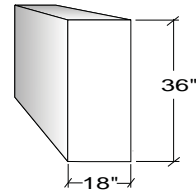

Width	Item Number
30"	5350040
36"	5450040
42"	5650040
48"	5550040
1000mm	5850040

**Sliding Door Units**



Width	Item Number
30"	5350050
36"	5450050
42"	5650050
48"	5550050
1000mm	5850050

*BLIND CORNER WALL CABINETS*

**Hinged Framed Door Units**



Width	Door On Right	Door On Left
30"	5350330	5350430
36"	5450330	5450430
42"	5650330	5650430
48"	5550330	5550430
1000mm	5850330	5850430

- Right Door Blind Corner Unit shown.
- Left Door Blind Corner Units are reverse of what is shown.
- Blind portion of cabinet is 18" wide on these units.

**Hinged Door Units**



Width	Door On Right	Door On Left
30"	5350360	5350460
36"	5450360	5450460
42"	5650360	5650460
48"	5550360	5550460
1000mm	5850360	5850460

- Right Door Blind Corner Unit shown.
- Left Door Blind Corner Units are reverse of what is shown.
- Blind portion of cabinet is 18" wide on these units.

*STEEL CASEWORK  
WALL CABINETS*

**Open Units**

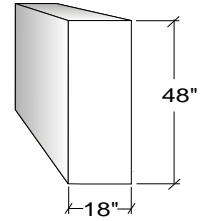

Width	Item Number
18"	5160010
24"	5260010
30"	5360010
36"	5460010
42"	5660010
48"	5560010
513mm	5960010
1000mm	5860010

**Hinged Framed Door Units**



up to 24" wide



30" and wider

Width	Right Hinged	Left Hinged	# of Doors
18"	5160030	5161030	1
24"	5260030	5261030	1
30"	5360030	-	2
36"	5460030	-	2
42"	5660030	-	2
48"	5560030	-	2
513mm	5960030	5961030	1
1000mm	5860030	-	2

**Hinged Door Units**



up to 24" wide



30" and wider

Width	Right Hinged	Left Hinged	# of Doors
18"	5160060	5161060	1
24"	5260060	5261060	1
30"	5360060	-	2
36"	5460060	-	2
42"	5660060	-	2
48"	5560060	-	2
513mm	5960060	5961060	1
1000mm	5860060	-	2

**Sliding Glass Door Units**



Width	Item Number
30"	5360020
36"	5460020
42"	5660020
48"	5560020
1000mm	5860020

*STEEL CASEWORK  
WALL CABINETS*

**Sliding Framed Door Units**

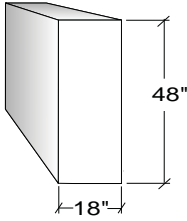

Width	Item Number
30"	5360040
36"	5460040
42"	5660040
48"	5560040
1000mm	5860040

**Sliding Door Units**



Width	Item Number
30"	5360050
36"	5460050
42"	5660050
48"	5560050
1000mm	5860050

*BLIND CORNER WALL CABINETS*

**Hinged Framed Door Units**



Width	Door On Right	Door On Left
30"	5360330	5360430
36"	5460330	5460430
42"	5660330	5660430
48"	5560330	5560430
1000mm	5860330	5860430

- Right Door Blind Corner Unit shown.
- Left Door Blind Corner Units are reverse of what is shown.
- Blind portion of cabinet is 18" wide on these units.

**Hinged Door Units**



Width	Door On Right	Door On Left
30"	5360360	5360460
36"	5460360	5460460
42"	5660360	5660460
48"	5560360	5560460
1000mm	5860360	5860460

- Right Door Blind Corner Unit shown.
- Left Door Blind Corner Units are reverse of what is shown.
- Blind portion of cabinet is 18" wide on these units.

*STEEL CASEWORK  
WALL CABINETS*

**Hinged Framed Door Units**

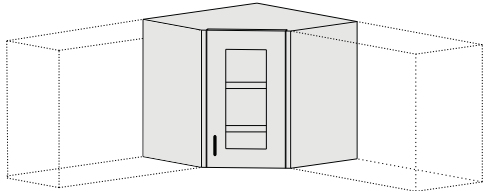
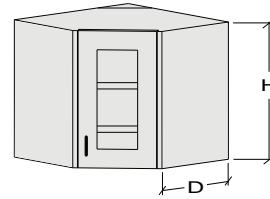

Height	Right Hinged	Left Hinged	Depth
24"	5070030	5071030	14"
30"	5010030	5011030	14"
36"	5020030	5021030	14"
48"	5030030	5031030	14"
24"	5080030	5081030	18"
30"	5040030	5041030	18"
36"	5050030	5051030	18"
48"	5060030	5061030	18"

**Hinged Door Units**

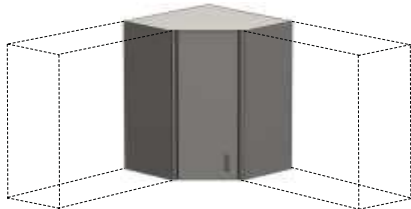

Height	Right Hinged	Left Hinged	Depth
24"	5070060	5071060	14"
30"	5010060	5011060	14"
36"	5020060	5021060	14"
48"	5030060	5031060	14"
24"	5080060	5081060	18"
30"	5040060	5041060	18"
36"	5050060	5051060	18"
48"	5060060	5061060	18"

*CONTEMPORARY INSET  
FLIPPER DOOR WALL CABINET*

**Flipper Door Units**

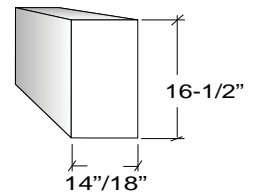

Width	Item Number	Depth
30"	53A0300	14"
36"	54A0300	14"
48"	55A0300	14"
30"	53B0300	18"
36"	54B0300	18"
48"	55B0300	18"

- The flipper door on these units swings up and into the cabinet body.
- Order this cabinet to match width of support structure frame.
- Add option code FR to suspend this wall cabinet from Sigma Cart™ and Sigma Flex™.
- Add option code HR to suspend this wall cabinet from Sigma Frame™.
- Shelf not provided.

*STEEL CASEWORK  
WALL CABINETS*

**Ordering Double Sided Wall Units**

Mott laboratory furniture is available with a wide variety of features to meet specific application requirements. The full range of our wall cabinets are available in our double sided design. To specify double sided wall cabinets, select the two digit part number suffix from below and add this suffix after the standard part number, separated with a dash.

**OVERVIEW EXAMPLE**

To order double sided wall cabinets:

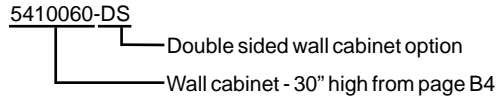

5410060



5410060-DS

**Sigma Flex™ Wall Cabinet Hanger Rails**

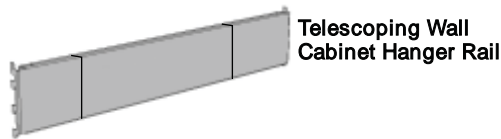

Telescoping Wall Cabinet Hanger Rail



Fixed Width Wall Cabinet Hanger Rail

Width	Telescoping Rail	Fixed Width Rail
24"	TWR0024	FWR0024
30"	TWR0030	FWR0030
36"	TWR0036	FWR0036
42"	TWR0042	FWR0042
48"	TWR0048	FWR0048
54"	TWR0054	FWR0054
60"	TWR0060	FWR0060
72"	TWR0072	FWR0072

- Sigma Flex™ Wall Cabinet Hanger Rails are required to hang above-counter storage cabinets on to Sigma Flex™ systems.
- Order rails to match width of support structure frame (Telescoping Rails are not suitable for cabinets smaller than 24" wide).
- Telescoping Rail is adjustable up to 5".
- Wall cabinets must be ordered with option code "FR" to suspend from Sigma Flex™ and Sigma Cart™ products. See wall cabinet section to order cabinets.

**Sigma Frame™ Wall Cabinet Hanger Rails**

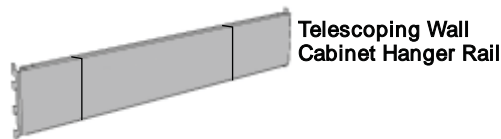

Telescoping Wall Cabinet Hanger Rail



Fixed Width Wall Cabinet Hanger Rail

Width	Telescoping Rail	Fixed Width Rail
24"	AWR0024	SWR0024
30"	AWR0030	SWR0030
36"	AWR0036	SWR0036
42"	AWR0042	SWR0042
48"	AWR0048	SWR0048
54"	AWR0054	SWR0054
60"	AWR0060	SWR0060
72"	AWR0072	SWR0072

- Sigma Frame™ Wall Cabinet Hanger Rails are required to hang above-counter storage cabinets on to Sigma Frame™ systems.
- Order rails to match width of support structure frame (Telescoping Rails are not suitable for cabinets smaller than 24" wide).
- Telescoping Rail is adjustable up to 5".
- Wall cabinets must be ordered with option code "HR" to suspend from Sigma Frame™ systems. See wall cabinet section to order cabinets.

*STEEL CASEWORK  
WALL CABINETS*

**Wall Cabinet "J" Mounting Rails**



Width	Item Number
24"	WHR0024
30"	WHR0030
36"	WHR0036
42"	WHR0042
48"	WHR0048
60"	WHR0060
72"	WHR0072

- A "J" Mounting Rail is required to hang metal above-counter storage cabinets on to Sigma Flex™ or Sigma Frame™ products.
- Order "J" rails to match width of support structure frame and Wall Cabinet Hanger Rail.
- "J" Rail ships loose.

**"Z" Wall Mounting Rail**

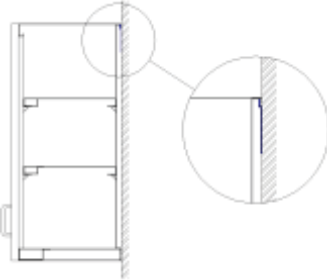

Option Code
ZR

- Add option code "ZR" to any wall cabinet to have a "Z" Mounting Rail shipped with the wall cabinet.
- The "Z" Mounting Rail is 16 gauge zinc coated steel and mounts to the wall to easily install and align wall cabinets.
- See wall cabinet section to order cabinets.
- "Z" Wall Mounting Rail ships loose.



*STEEL CASEWORK  
FLOOR CABINETS*

**Open Units**

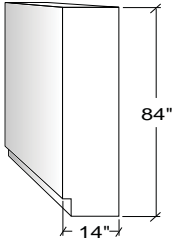
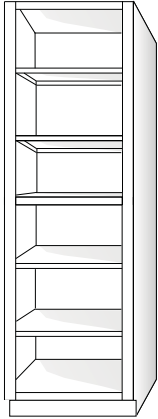

Width	Item Number
18"	6110010
24"	6210010
30"	6310010
36"	6410010
42"	6610010
48"	6510010
513mm	6910010
1000mm	6810010

**Hinged Framed Door Units**

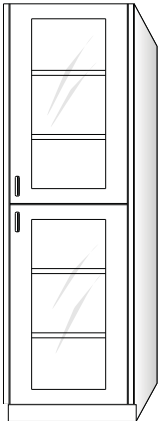

up to 24" wide

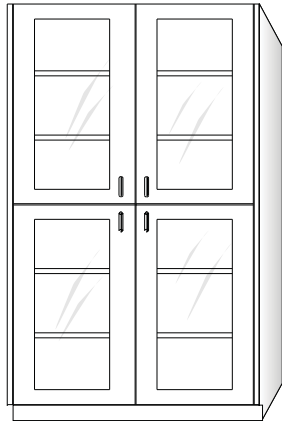

30" and wider

Width	Right Hinged	Left Hinged	# of Doors
18"	6110030	6110230	2
24"	6210030	6210230	2
30"	6310030	-	4
36"	6410030	-	4
42"	6610030	-	4
48"	6510030	-	4
513mm	6910030	6910230	2
1000mm	6810030	-	4

- Add Option Code 80 to order full height doors.
- Full height door units have a fixed center shelf.

**Hinged Door Units**

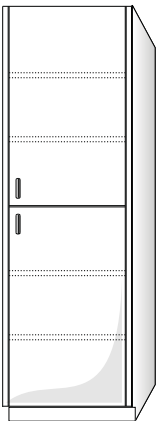

up to 24" wide

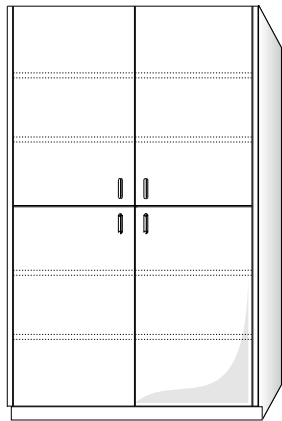

30" and wider

Width	Right Hinged	Left Hinged	# of Doors
18"	6110060	6110260	2
24"	6210060	6210260	2
30"	6310060	-	4
36"	6410060	-	4
42"	6610060	-	4
48"	6510060	-	4
513mm	6910060	6910260	2
1000mm	6810060	-	4

- Add Option Code 80 to order full height doors.
- Full height door units have a fixed center shelf.

*STEEL CASEWORK  
FLOOR CABINETS*

**Sliding Glass Door Units**

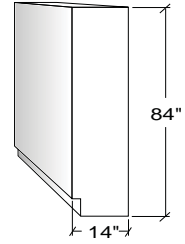

Width	Item Number
30"	6310020
36"	6410020
42"	6610020
48"	6510020
1000mm	6810020

- Add Option Code 80 to order full height doors.

**Sliding Framed Door Units**



Width	Item Number
30"	6310040
36"	6410040
42"	6610040
48"	6510040
1000mm	6810040

- Add Option Code 80 to order full height doors.

**Sliding Door Units**

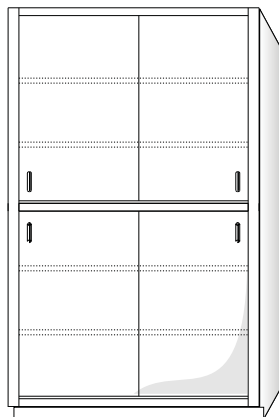

Width	Item Number
30"	6310050
36"	6410050
42"	6610050
48"	6510050
1000mm	6810050

- Add Option Code 80 to order full height doors.

*STEEL CASEWORK  
FLOOR CABINETS*

**Open Units**

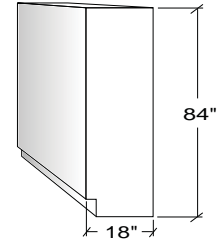
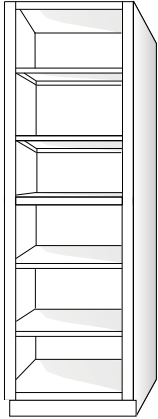

Width	Item Number
18"	6120010
24"	6220010
30"	6320010
36"	6420010
42"	6620010
48"	6520010
513mm	6920010
1000mm	6820010

**Hinged Framed Door Units**

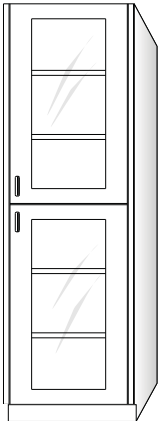

up to 24" wide

30" and wider

Width	Right Hinged	Left Hinged	# of Doors
18"	6120030	6120230	2
24"	6220030	6220230	2
30"	6320030	-	4
36"	6420030	-	4
42"	6620030	-	4
48"	6520030	-	4
513mm	6920030	6920230	2
1000mm	6820030	-	4

- Add Option Code 80 to order full height doors.
- Full height door units have a fixed center shelf.

**Hinged Door Units**

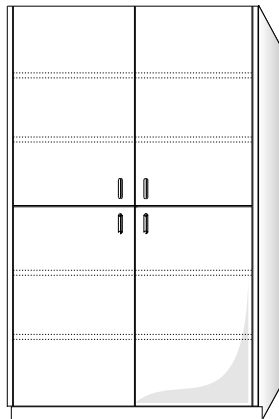
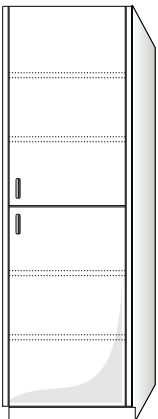

up to 24" wide

30" and wider

Width	Right Hinged	Left Hinged	# of Doors
18"	6120060	6120260	2
24"	6220060	6220260	2
30"	6320060	-	4
36"	6420060	-	4
42"	6620060	-	4
48"	6520060	-	4
513mm	6920060	6920260	2
1000mm	6820060	-	4

- Add Option Code 80 to order full height doors.
- Full height door units have a fixed center shelf.

*STEEL CASEWORK  
FLOOR CABINETS*

**Sliding Glass Door Units**

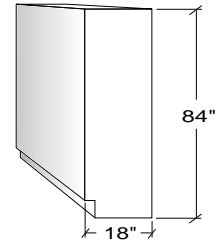

Width	Item Number
30"	6320020
36"	6420020
42"	6620020
48"	6520020
1000mm	6820020

- Add Option Code 80 to order full height doors.

**Sliding Framed Door Units**

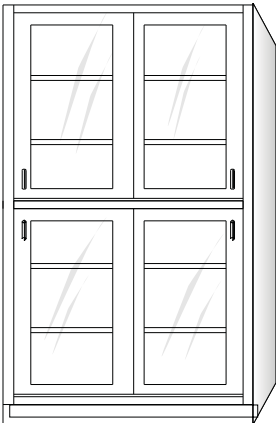

Width	Item Number
30"	6320040
36"	6420040
42"	6620040
48"	6520040
1000mm	6820040

- Add Option Code 80 to order full height doors.

**Sliding Door Units**

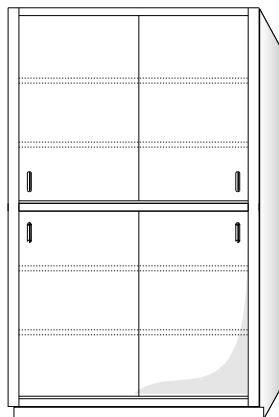

Width	Item Number
30"	6320050
36"	6420050
42"	6620050
48"	6520050
1000mm	6820050

- Add Option Code 80 to order full height doors.

*STEEL CASEWORK  
FLOOR CABINETS*

**Open Units**

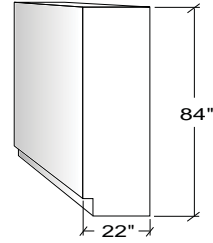
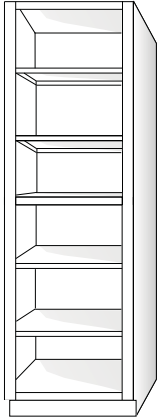

Width	Item Number
18"	6130010
24"	6230010
30"	6330010
36"	6430010
42"	6630010
48"	6530010
513mm	6930010
1000mm	6830010

**Hinged Framed Door Units**

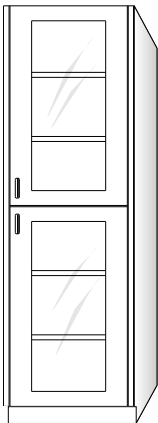

up to 24" wide



30" and wider

Width	Right Hinged	Left Hinged	# of Doors
18"	6130030	6130230	2
24"	6230030	6230230	2
30"	6330030	-	4
36"	6430030	-	4
42"	6630030	-	4
48"	6530030	-	4
513mm	6930030	6930230	2
1000mm	6830030	-	4

- Add Option Code 80 to order full height doors.
- Full height door units have a fixed center shelf.

**Hinged Door Units**

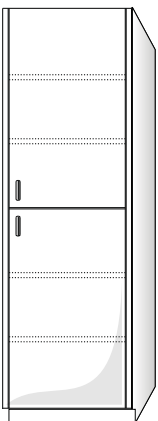

up to 24" wide

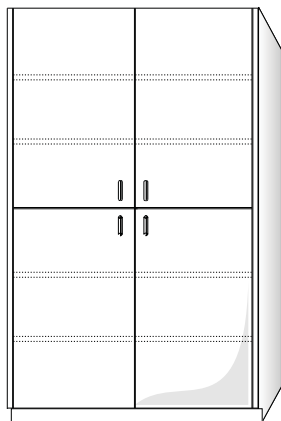

30" and wider

Width	Right Hinged	Left Hinged	# of Doors
18"	6130060	6130260	2
24"	6230060	6230260	2
30"	6330060	-	4
36"	6430060	-	4
42"	6630060	-	4
48"	6530060	-	4
513mm	6930060	6930260	2
1000mm	6830060	-	4

- Add Option Code 80 to order full height doors.
- Full height door units have a fixed center shelf.

*STEEL CASEWORK  
FLOOR CABINETS*

**Sliding Glass Door Units**

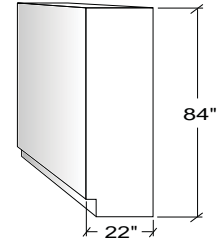

Width	Item Number
30"	6330020
36"	6430020
42"	6630020
48"	6530020
1000mm	6830020

- Add Option Code 80 to order full height doors.

**Sliding Framed Door Units**

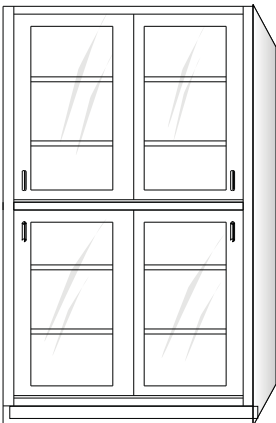

Width	Item Number
30"	6330040
36"	6430040
42"	6630040
48"	6530040
1000mm	6830040

- Add Option Code 80 to order full height doors.

**Sliding Door Units**

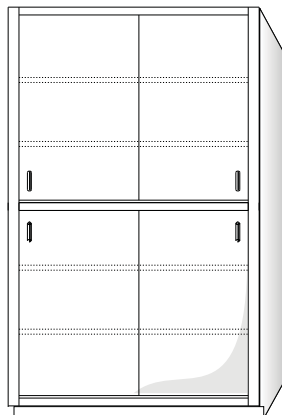

Width	Item Number
30"	6330050
36"	6430050
42"	6630050
48"	6530050
1000mm	6830050

- Add Option Code 80 to order full height doors.

*STEEL CASEWORK  
SPECIALTY FLOOR CABINETS*

**Wardrobe Units**

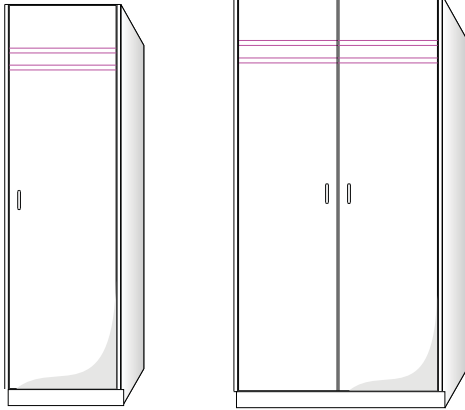
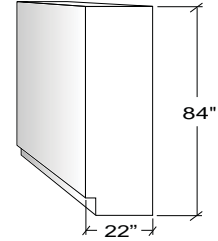

up to 24" wide

30" and wider

Width	Right Hinged	Left Hinged	# of Doors
15"	6A35060	6A35260	1
18"	6135060	6135260	1
24"	6235060	6235260	1
30"	6335060	-	2
36"	6435060	-	2
42"	6635060	-	2
48"	6535060	-	2
513mm	6935060	6935260	1

- Wardrobe Units have solid hinged double doors and include one stationary shelf and a clothes rod.
- Units must have a minimum depth of 22" to hold hangers.
- Mirror is not included.

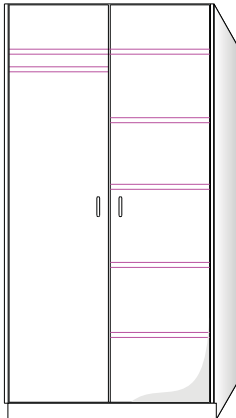

Width	Item Number
30"	6335660
36"	6435660
42"	6635660
48"	6535660

- Wardrobe Units have solid hinged double doors and include one fixed shelf with attached clothes rod on the left side with one fixed shelf and four adjustable shelves on the right side.
- Units must have a minimum depth of 22" to hold hangers.
- Mirror is not included.

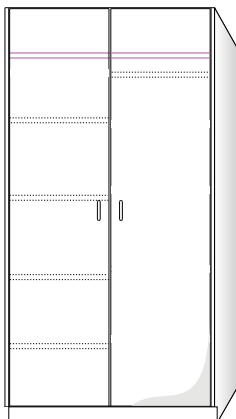

Width	Item Number
30"	6335760
36"	6435760
42"	6635760
48"	6535760

- Wardrobe Units have solid hinged double doors and include one fixed shelf with attached clothes rod on the right side with one fixed shelf and four adjustable shelves on the left side.
- Units must have a minimum depth of 22" to hold hangers.
- Mirror is not included.



*STEEL CASEWORK  
SPECIALTY FLOOR CABINETS*

**Instrument Storage Units**

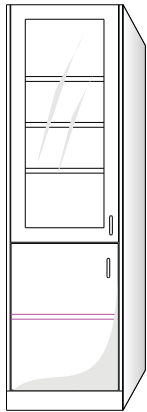
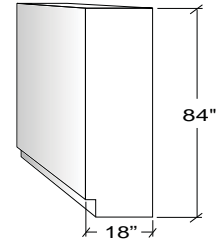

up to 24" wide

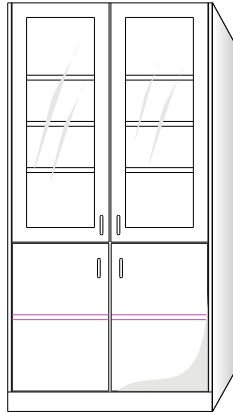

30" and wider

Width	Right Hinged	Left Hinged	# of Doors
18"	61200A0	61202A0	2
24"	62200A0	62202A0	2
30"	63200A0	-	4
36"	64200A0	-	4
42"	66200A0	-	4
48"	65200A0	-	4
513mm	69200A0	69202A0	2
1000mm	68200A0	-	4

- The upper section on the Instrument Storage Units has hinged framed glass doors with three adjustable shelves inside.
- The lower section is 34-3/4" high, with hinged solid doors and one adjustable shelf inside.



Width	Item Number
30"	63200B0
36"	64200B0
42"	66200B0
48"	65200B0
1000mm	68200B0

- The upper section on the Instrument Storage Units has sliding framed glass doors with three adjustable shelves inside.
- The lower section is 34-3/4" high, with hinged solid doors, one adjustable shelf inside and two pull-out boards.



Width	Item Number
30"	63200C0
36"	64200C0
42"	66200C0
48"	65200C0
1000mm	68200C0

- The upper section on the Instrument Storage Units has sliding framed glass doors with three adjustable shelves inside.
- The lower section is 34-3/4" high, with sliding solid doors, one adjustable shelf inside and two pull-out boards.

*STEEL CASEWORK  
SPECIALTY FLOOR CABINETS*

**Instrument Storage Units**

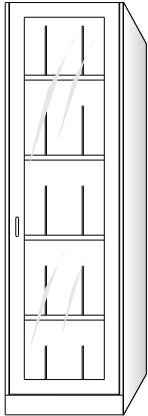
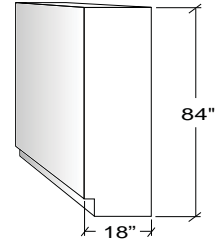

24" wide

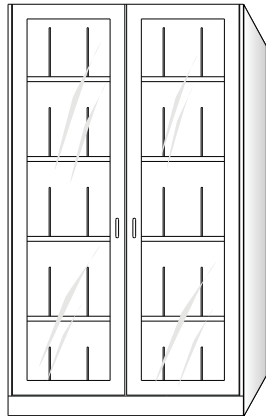

48" wide

Width	Right Hinged	Left Hinged
24"	6227030	6227230
48"	6527030	-

- The 24" wide Instrument Storage Units have a hinged framed glass door with 15 compartments.
- The 48" wide Instrument Storage Unit has hinged framed glass double doors with 30 compartments.
- Unit comes with four adjustable shelves.

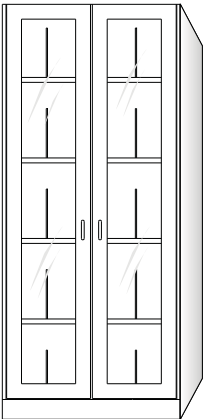

36" wide

Width	Item Number
36"	6427030

- The 36" wide Instrument Storage Unit has hinged framed glass double doors with 20 compartments.
- Unit comes with four adjustable shelves.

**Tool Storage Units**

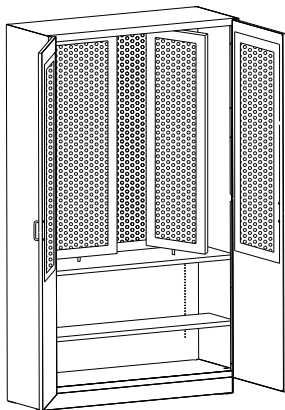

Width	Item Number
30"	6338060
36"	6438060
42"	6638060
48"	6538060

- Tool Storage Units have solid hinged double doors and include one adjustable shelf at bottom, one pegboard on inside of each door, one pegboard on inside back and two rotating pegboards.
- The pegboards on these units are metal.
- Pegs are not included.
- These units fit most standard tool pegs.

*STEEL CASEWORK  
SPECIALTY CABINETS - STANDING HEIGHT*

**Acid Storage Units (22" Deep)**

See page E18 for vent hole locations.



up to 24" wide



30" and wider

Width	Right Hinged	Left Hinged	# of Doors
15"	1911011	1911211	1
18"	1111011	1111211	1
24"	1211011	1211211	1
30"	1311011	-	2
36"	1411011	-	2
42"	1811011	-	2
48"	1511011	-	2
513mm	1611011	1611211	1
1000mm	1711011	-	2

- Lined with a chemically resistant molded liner and has one black phenolic shelf.
- Add Option Code VK to order a Corrugated Polyolefin Vent Kit for these units.
- Add Option Code 82 to change liner to a FRP liner.



up to 24" wide



30" and wider

Width	Right Hinged	Left Hinged	# of Doors
15"	1916022	1916222	1
18"	1116022	1116222	1
24"	1216022	1216222	1
30"	1316022	-	2
36"	1416022	-	2
42"	1816022	-	2
48"	1516022	-	2
513mm	1616022	1616222	1
1000mm	1716022	-	2

- Lined with a chemically resistant molded liner and has one black phenolic shelf.
- Add Option Code VK to order a Corrugated Polyolefin Vent Kit for these units.
- Add Option Code 82 to change liner to a FRP liner.

**Acid Storage Units (18" Deep)**



up to 24" wide



30" and wider

Width	Right Hinged	Left Hinged	# of Doors
18"	1131011	1131211	1
24"	1231011	1231211	1
30"	1331011	-	2
36"	1431011	-	2
42"	1831011	-	2
48"	1531011	-	2
513mm	1631011	1631211	1
1000mm	1731011	-	2

- Lined with a chemically resistant molded liner and has one black phenolic shelf.
- Add Option Code VK to order a Corrugated Polyolefin Vent Kit for these units.
- Add Option Code 82 to change liner to a FRP liner.



up to 24" wide



30" and wider

Width	Right Hinged	Left Hinged	# of Doors
15"	1936022	1936222	1
18"	1136022	1136222	1
24"	1236022	1236222	1
30"	1336022	-	2
36"	1436022	-	2
42"	1836022	-	2
48"	1536022	-	2
513mm	1636022	1636222	1
1000mm	1736022	-	2

- Lined with a chemically resistant molded liner and has one black phenolic shelf.
- Add Option Code VK to order a Corrugated Polyolefin Vent Kit for these units.
- Add Option Code 82 to change liner to a FRP liner.

*STEEL CASEWORK  
SPECIALTY CABINETS - SITTING HEIGHT*

**Acid Storage Units (22" Deep)**

See page E18 for vent hole locations.

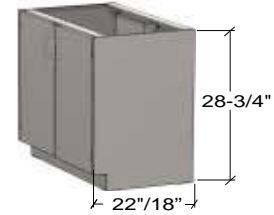

up to 24" wide



30" and wider

Width	Right Hinged	Left Hinged	# of Doors
15"	1921011	1921211	1
18"	1121011	1121211	1
24"	1221011	1221211	1
30"	1321011	-	2
36"	1421011	-	2
42"	1821011	-	2
48"	1521011	-	2
513mm	1621011	1621211	1
1000mm	1721011	-	2

- Lined with a chemically resistant molded liner and has one black phenolic shelf.
- Add Option Code VK to order a Corrugated Polyolefin Vent Kit for these units.
- Add Option Code 82 to change liner to a FRP liner.



up to 24" wide



30" and wider

Width	Right Hinged	Left Hinged	# of Doors
15"	1926022	1926222	1
18"	1126022	1126222	1
24"	1226022	1226222	1
30"	1326022	-	2
36"	1426022	-	2
42"	1826022	-	2
48"	1526022	-	2
513mm	1626022	1626222	1
1000mm	1726022	-	2

- Lined with a chemically resistant molded liner and has one black phenolic shelf.
- Add Option Code VK to order a Corrugated Polyolefin Vent Kit for these units.
- Add Option Code 82 to change liner to a FRP liner.

**Acid Storage Units (18" Deep)**



up to 24" wide



30" and wider

Width	Right Hinged	Left Hinged	# of Doors
15"	1941011	1941211	1
18"	1141011	1141211	1
24"	1241011	1241211	1
30"	1341011	-	2
36"	1441011	-	2
42"	1841011	-	2
48"	1541011	-	2
513mm	1641011	1641211	1
1000mm	1741011	-	2

- Lined with a chemically resistant molded liner and has one black phenolic shelf.
- Add Option Code VK to order a Corrugated Polyolefin Vent Kit for these units.
- Add Option Code 82 to change liner to a FRP liner.



up to 24" wide



30" and wider

Width	Right Hinged	Left Hinged	# of Doors
15"	1946022	1946222	1
18"	1146022	1146222	1
24"	1246022	1246222	1
30"	1346022	-	2
36"	1446022	-	2
42"	1846022	-	2
48"	1546022	-	2
513mm	1646022	1646222	1
1000mm	1746022	-	2

- Lined with a chemically resistant molded liner and has one black phenolic shelf.
- Add Option Code VK to order a Corrugated Polyolefin Vent Kit for these units.
- Add Option Code 82 to change liner to a FRP liner.

*STEEL CASEWORK  
SPECIALTY CABINETS - ADA HEIGHT*

**Acid Storage Units (22" Deep)**

See page E18 for vent hole locations.



up to 24" wide



30" and wider

Width	Right Hinged	Left Hinged	# of Doors
15"	1981011	1981211	1
18"	1181011	1181211	1
24"	1281011	1281211	1
30"	1381011	-	2
36"	1481011	-	2
42"	1881011	-	2
48"	1581011	-	2
513mm	1681011	1681211	1
1000mm	1781011	-	2

- Lined with a chemically resistant molded liner and has one black phenolic shelf.
- Add Option Code VK to order a Corrugated Polyolefin Vent Kit for these units.
- Add Option Code 82 to change liner to a FRP liner.



up to 24" wide



30" and wider

Width	Right Hinged	Left Hinged	# of Doors
15"	1986022	1986222	1
18"	1186022	1186222	1
24"	1286022	1286222	1
30"	1386022	-	2
36"	1486022	-	2
42"	1886022	-	2
48"	1586022	-	2
513mm	1686022	1686222	1
1000mm	1786022	-	2

- Lined with a chemically resistant molded liner and has one black phenolic shelf.
- Add Option Code VK to order a Corrugated Polyolefin Vent Kit for these units.
- Add Option Code 82 to change liner to a FRP liner.

*SPECIALTY CABINETS - 84" HIGH*

**Acid Storage Units (18" & 22" Deep)**

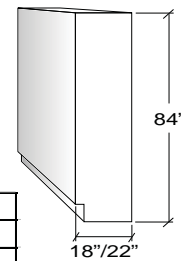

Width	18" Deep	22" Deep
30"	6322480	6332480
36"	6422480	6432480
42"	6622480	6632480
48"	6522480	6532480

- Unit includes four adjustable phenolic shelves, one fixed center shelf and a 4" high x 4" diameter stub for exhaust duct connection located 4-3/8" from rear of cabinet.
- This unit comes with Fiber Reinforced Polyester (FRP) lining.
- Add option code 04 to add a standard louver configuration to this unit.

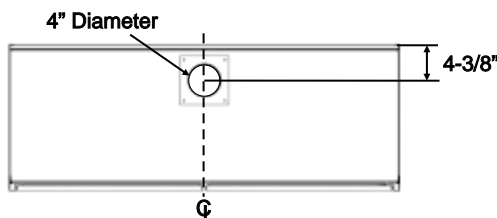

### STEEL CASEWORK SPECIALTY CABINETS - STANDING HEIGHT

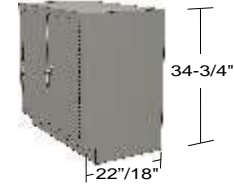

#### Insulated Solvent Units (22" Deep)

See page E18 for vent hole locations.



up to 24" wide



30" and wider



up to 24" wide

30" and wider

Width	Right Hinged	Left Hinged	# of Doors
15"	1912011	1912111	1
18"	1112011	1112111	1
24"	1212011	1212111	1
30"	1312011	-	2
36"	1412011	-	2
42"	1812011	-	2
48"	1512011	-	2
513mm	1612011	1612111	1
1000mm	1712011	-	2

- Solvent Units are UL standard 1275 listed.
- Add Option Code 83 to order Self Closing/Latching doors.
- Add Option Code "FL" to order self closing/latching doors with a fusible link.

Width	Right Hinged	Left Hinged	# of Doors
15"	1912022	1912122	1
18"	1112022	1112122	1
24"	1212022	1212122	1
30"	1312022	-	2
36"	1412022	-	2
42"	1812022	-	2
48"	1512022	-	2
513mm	1612022	1612122	1
1000mm	1712022	-	2

- Includes sitting height UL listed Insulated Solvent Cabinet.
- Add Option Code 83 to order Self Closing/Latching doors.
- Upper apron assemblies are 6" high. Not UL approved with electrical installed.
- If Variac is required, upper aprons are 7-1/4" high.
- Add Option Code "FL" to order self closing/latching doors with a fusible link
- Dimensional modifications may invalidate the UL listing - contact Mott for more information.

#### Insulated Solvent Units (18" Deep)



up to 24" wide



30" and wider



up to 24" wide

30" and wider

Width	Right Hinged	Left Hinged	# of Doors
15"	1932011	1932111	1
18"	1132011	1132111	1
24"	1232011	1232111	1
30"	1332011	-	2
36"	1432011	-	2
42"	1832011	-	2
48"	1532011	-	2
513mm	1632011	1632111	1
1000mm	1732011	-	2

- Solvent Units are UL standard 1275 listed.
- Add Option Code 83 to order Self Closing/Latching doors.
- Add Option Code "FL" to order self closing/latching doors with a fusible link.

Width	Right Hinged	Left Hinged	# of Doors
15"	1932022	1932122	1
18"	1132022	1132122	1
24"	1232022	1232122	1
30"	1332022	-	2
36"	1432022	-	2
42"	1832022	-	2
48"	1532022	-	2
513mm	1632022	1632122	1
1000mm	1732022	-	2

- Includes sitting height UL listed Insulated Solvent Cabinet.
- Add Option Code 83 to order Self Closing/Latching doors.
- Upper apron assemblies are 6" high. Not UL approved with electrical installed.
- If Variac is required, upper aprons are 7-1/4" high.
- Add Option Code "FL" to order self closing/latching doors with a fusible link.
- Dimensional modifications may invalidate the UL listing - contact Mott for more information.



*STEEL CASEWORK  
SPECIALTY CABINETS - SITTING HEIGHT*

**Insulated Solvent Units (22" Deep)** See page E18 for vent hole locations.

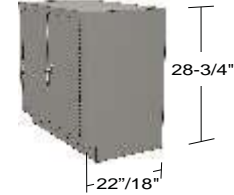

up to 24" wide

30" and wider

Width	Right Hinged	Left Hinged	# of Doors
15"	1922011	1922111	1
18"	1122011	1122111	1
24"	1222011	1222111	1
30"	1322011	-	2
36"	1422011	-	2
42"	1822011	-	2
48"	1522011	-	2
513mm	1622011	1622111	1
1000mm	1722011	-	2

- Solvent Units are UL standard 1275 listed.
- Add Option Code 83 to order Self Closing/Latching doors.
- Add Option Code "FL" to order self closing/latching doors with a fusible link.

**Insulated Solvent Units (18" Deep)**



up to 24" wide

30" and wider

Width	Right Hinged	Left Hinged	# of Doors
15"	1942011	1942111	1
18"	1142011	1142111	1
24"	1242011	1242111	1
30"	1342011	-	2
36"	1442011	-	2
42"	1842011	-	2
48"	1542011	-	2
513mm	1642011	1642111	1
1000mm	1742011	-	2

- Solvent Units are UL standard 1275 listed.
- Add Option Code 83 to order Self Closing/Latching doors.
- Add Option Code "FL" to order self closing/latching doors with a fusible link.

*SPECIALTY CABINETS - ADA HEIGHT*

**Insulated Solvent Units (22" Deep)**

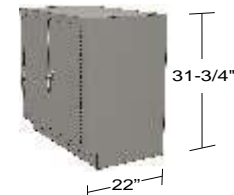

up to 24" wide

30" and wider

Width	Right Hinged	Left Hinged	# of Doors
15"	1982011	1982111	1
18"	1182011	1182111	1
24"	1282011	1282111	1
30"	1382011	-	2
36"	1482011	-	2
42"	1882011	-	2
48"	1582011	-	2
513mm	1682011	1682111	1
1000mm	1782011	-	2

- Solvent Units are UL standard 1275 listed.
- Add Option Code 83 to order Self Closing/Latching doors.
- Add Option Code "FL" to order self closing/latching doors with a fusible link.

*STEEL CASEWORK  
SPECIALTY CABINETS - 44" HIGH*

**Insulated Solvent Units (18" Deep)**

See page E18 for vent hole locations.

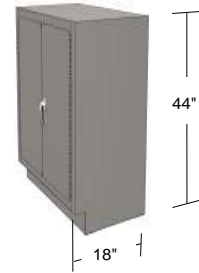

Width	Item Number
36"	6444160
42"	6644160
48"	6544160

- Solvent Units are designed to OSHA and NFPA 30 standards.
- Add Option Code 83 to order Self Closing/Latching doors.
- Add Option Code "FL" to order self closing/latching doors with a fusible link.
- These units include threaded vent connections in the back (standard location) with flame arresting screen and a three point locking handle.
- For threaded vent connections on both sides with flame arresting screen use Option Code "VS".
- If variac is required, upper apron on the above units are 7-1/4" high.
- Includes two adjustable shelves.

*SPECIALTY CABINETS - 65" HIGH*

**Insulated Solvent Units (18" Deep)**

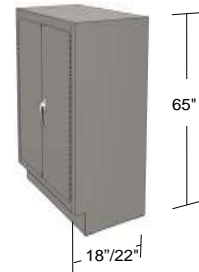

Width	Item Number
36"	6454160
42"	6654160
48"	6554160

- Solvent Units are designed to OSHA and NFPA 30 standards.
- Add Option Code 83 to order Self Closing/Latching doors.
- Add Option Code "FL" to order self closing/latching doors with a fusible link.
- These units include threaded vent connections in the back (standard location) with flame arresting screen and a three point locking handle.
- For threaded vent connections on both sides with flame arresting screen use Option Code "VS".
- If variac is required, upper apron on the above units are 7-1/4" high.
- Includes three adjustable shelves.

**Insulated Solvent Units (22" Deep)**



Width	Item Number
36"	6464160
42"	6664160
48"	6564160

- Solvent Units are designed to OSHA and NFPA 30 standards.
- Add Option Code 83 to order Self Closing/Latching doors.
- Add Option Code "FL" to order self closing/latching doors with a fusible link.
- These units include threaded vent connections in the back (standard location) with flame arresting screen and a three point locking handle.
- For threaded vent connections on both sides with flame arresting screen use Option Code "VS".
- If variac is required, upper apron on the above units are 7-1/4" high.
- Includes three adjustable shelves.



*STEEL CASEWORK  
SPECIALTY CABINETS - STANDING HEIGHT*

**Solvent Storage Units (22" Deep)**

See page E18 for vent hole locations.

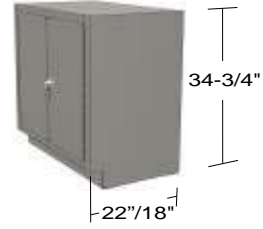

up to 24" wide



30" and wider

Width	Right Hinged	Left Hinged	# of Doors
15"	1912211	1912311	1
18"	1112211	1112311	1
24"	1212211	1212311	1
30"	1312211	-	2
36"	1412211	-	2
42"	1812211	-	2
48"	1512211	-	2
513mm	1612211	1612311	1
1000mm	1712211	-	2

- Solvent Units are not insulated.
- These units are designed to meet OSHA and NFPA 30 standards.
- Add Option Code 83 to order Self Closing/Latching doors.
- Add Option Code "FL" to order self closing/latching doors with a fusible link.

**Solvent Storage Units (18" Deep)**



up to 24" wide



30" and wider

Width	Right Hinged	Left Hinged	# of Doors
15"	1932211	1932311	1
18"	1132211	1132311	1
24"	1232211	1232311	1
30"	1332211	-	2
36"	1432211	-	2
42"	1832211	-	2
48"	1532211	-	2
513mm	1632211	1632311	1
1000mm	1732211	-	2

- Solvent Units are not insulated.
- These units are designed to meet OSHA and NFPA 30 standards.
- Add Option Code 83 to order Self Closing/Latching doors.
- Add Option Code "FL" to order self closing/latching doors with a fusible link.

*STEEL CASEWORK  
SPECIALTY CABINETS - SITTING HEIGHT*

**Solvent Storage Units (22" Deep)**

See page E18 for vent hole locations.

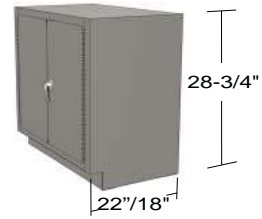

up to 24" wide



30" and wider

Width	Right Hinged	Left Hinged	# of Doors
15"	1922211	1922311	1
18"	1122211	1122311	1
24"	1222211	1222311	1
30"	1322211	-	2
36"	1422211	-	2
42"	1822211	-	2
48"	1522211	-	2
513mm	1622211	1622311	1
1000mm	1722211	-	2

- Solvent Units are not insulated.
- These units are designed to meet OSHA and NFPA 30 standards.
- Add Option Code 83 to order Self Closing/Latching doors.
- Add Option Code "FL" to order self closing/latching doors with a fusible link.

**Solvent Storage Units (18" Deep)**



up to 24" wide



30" and wider

Width	Right Hinged	Left Hinged	# of Doors
15"	1942211	1942311	1
18"	1142211	1142311	1
24"	1242211	1242311	1
30"	1342211	-	2
36"	1442211	-	2
42"	1842211	-	2
48"	1542211	-	2
513mm	1642211	1642311	1
1000mm	1742211	-	2

- Solvent Units are not insulated.
- These units are designed to meet OSHA and NFPA 30 standards.
- Add Option Code 83 to order Self Closing/Latching doors.
- Add Option Code "FL" to order self closing/latching doors with a fusible link.

*SPECIALTY CABINETS - ADA HEIGHT*

**Solvent Storage Units (22" Deep)**



up to 24" wide



30" and wider

Width	Right Hinged	Left Hinged	# of Doors
15"	1982211	1982311	1
18"	1182211	1182311	1
24"	1282211	1282311	1
30"	1382211	-	2
36"	1482211	-	2
42"	1882211	-	2
48"	1582211	-	2
513mm	1682211	1682311	1
1000mm	1782211	-	2

- Solvent Units are not insulated.
- These units are designed to meet OSHA and NFPA 30 standards.
- Add Option Code 83 to order Self Closing/Latching doors.
- Add Option Code "FL" to order self closing/latching doors with a fusible link.

*STEEL CASEWORK  
SPECIALTY CABINETS - 44" HIGH*

**Solvent Storage Units (18" Deep)**

See page E18 for vent hole locations.

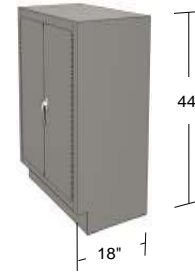

Width	Item Number
36"	6443160
42"	6743160
48"	6543160

- Solvent Units are not insulated.
- These units are designed to OSHA and NFPA 30 standards.
- Add Option Code 83 to order Self Closing/Latching doors.
- Add Option Code "FL" to order self closing/latching doors with a fusible link.
- These units include threaded vent connections in back with flame arresting screen and a three point locking handle.
- Add option code VS for vent holes on side of cabinet.

*SPECIALTY CABINETS - 65" HIGH*

**Solvent Storage Units (18" Deep)**

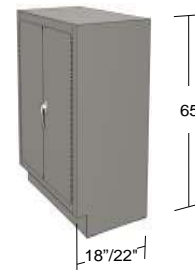

Width	Item Number
36"	6453160
42"	6753160
48"	6553160

- Solvent Units are not insulated.
- These units are designed to OSHA and NFPA 30 standards.
- Add Option Code 83 to order Self Closing/Latching doors.
- Add Option Code "FL" to order self closing/latching doors with a fusible link.
- These units include threaded vent connections in back with flame arresting screen and a three point locking handle.
- Add option code VS for vent holes on side of cabinet.

**Solvent Storage Units (22" Deep)**



Width	Item Number
36"	6463160
42"	6763160
48"	6563160

- Solvent Units are not insulated.
- These units are designed to OSHA and NFPA 30 standards.
- Add Option Code 83 to order Self Closing/Latching doors.
- Add Option Code "FL" to order self closing/latching doors with a fusible link.
- These units include threaded vent connections in back with flame arresting screen and a three point locking handle.
- Add option code VS for vent holes on side of cabinet.

*STEEL CASEWORK  
SPECIALTY CABINETS - SITTING HEIGHT*

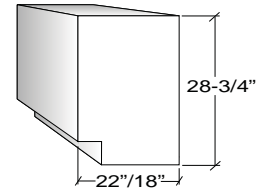

**Pump Storage Cabinets (22" Deep)**



up to 24" wide



30" and wider

Width	Right Hinged	Left Hinged	# of Doors
15"	192P011	192P211	1
18"	112P011	112P211	1
24"	122P011	122P211	1
30"	132P011	-	2
36"	142P011	-	2
42"	182P011	-	2
48"	152P011	-	2
513mm	162P011	162P211	1
1000mm	172P011	-	2

- See "Note 1" on page E12.
- Add Option Code PF for optional pump storage cabinet fan.



up to 24" wide



30" and wider

Width	Right Hinged	Left Hinged	# of Doors
15"	192P022	192P222	1
18"	112P022	112P222	1
24"	122P022	122P222	1
30"	132P022	-	2
36"	142P022	-	2
42"	182P022	-	2
48"	152P022	-	2
513mm	162P022	162P222	1
1000mm	172P022	-	2

- See "Note 2" on page E12.
- Add Option Code PF for optional pump storage cabinet fan.

**Pump Storage Cabinets (18" Deep)**



up to 24" wide



30" and wider

Width	Right Hinged	Left Hinged	# of Doors
15"	194P011	194P211	1
18"	114P011	114P211	1
24"	124P011	124P211	1
30"	134P011	-	2
36"	144P011	-	2
42"	184P011	-	2
48"	154P011	-	2
513mm	164P011	164P211	1
1000mm	174P011	-	2

- See "Note 1" on page E12.
- Add Option Code PF for optional pump storage cabinet fan.



up to 24" wide



30" and wider

Width	Right Hinged	Left Hinged	# of Doors
15"	194P022	194P222	1
18"	114P022	114P222	1
24"	124P022	124P222	1
30"	134P022	-	2
36"	144P022	-	2
42"	184P022	-	2
48"	154P022	-	2
513mm	164P022	164P222	1
1000mm	174P022	-	2

- See "Note 2" on page E12.
- Add Option Code PF for optional pump storage cabinet fan.

*STEEL CASEWORK  
SPECIALTY CABINETS - STANDING HEIGHT*

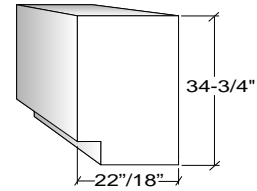

**Pump Storage Cabinets (22" Deep)**



up to 24" wide



30" and wider

Width	Right Hinged	Left Hinged	# of Doors
15"	191P011	191P211	1
18"	111P011	111P211	1
24"	121P011	121P211	1
30"	131P011	-	2
36"	141P011	-	2
42"	181P011	-	2
48"	151P011	-	2
513mm	161P011	161P211	1
1000mm	171P011	-	2

- See "Note 1" on page E12.
- Add Option Code PF for optional pump storage cabinet fan.



up to 24" wide



30" and wider

Width	Right Hinged	Left Hinged	# of Doors
15"	191P022	191P222	1
18"	111P022	111P222	1
24"	121P022	121P222	1
30"	131P022	-	2
36"	141P022	-	2
42"	181P022	-	2
48"	151P022	-	2
513mm	161P022	161P222	1
1000mm	171P022	-	2

- See "Note 2" on page E12.
- Add Option Code PF for optional pump storage cabinet fan.

**Pump Storage Cabinets (18" Deep)**



up to 24" wide



30" and wider

Width	Right Hinged	Left Hinged	# of Doors
15"	193P011	193P211	1
18"	113P011	113P211	1
24"	123P011	123P211	1
30"	133P011	-	2
36"	143P011	-	2
42"	183P011	-	2
48"	153P011	-	2
513mm	163P011	163P211	1
1000mm	173P011	-	2

- See "Note 1" on page E12.
- Add Option Code PF for optional pump storage cabinet fan.



up to 24" wide



30" and wider

Width	Right Hinged	Left Hinged	# of Doors
15"	193P022	193P222	1
18"	113P022	113P222	1
24"	123P022	123P222	1
30"	133P022	-	2
36"	143P022	-	2
42"	183P022	-	2
48"	153P022	-	2
513mm	163P022	163P222	1
1000mm	173P022	-	2

- See "Note 2" on page E12.
- Add Option Code PF for optional pump storage cabinet fan.

*STEEL CASEWORK  
SPECIALTY CABINETS - ADA HEIGHT*

**Pump Storage Cabinets (22" Deep)**

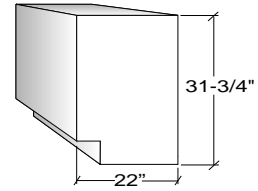

up to 24" wide



30" and wider

Width	Right Hinged	Left Hinged	# of Doors
15"	198P011	198P211	1
18"	118P011	118P211	1
24"	128P011	128P211	1
30"	138P011	-	2
36"	148P011	-	2
42"	188P011	-	2
48"	158P011	-	2
513mm	168P011	168P211	1
1000mm	178P011	-	2

**Note 1:**

- Pump Storage Cabinets with full doors are insulated with sound absorption foam for noise reduction.
- Vent hose connection and 120V/20amp,(15amp in Canada) duplex receptacle is located on the rear of the cabinet. Duplex and cover plate are black.
- These units include a pull-out tray and removable access panel at the back of the cabinet.
- Add Option Code PF for optional pump cabinet fan.
- Vibration isolators are available, contact Mott for details.
- Fan information: 115 VAC  
120 X 120 X 38mm  
81 CFM



up to 24" wide



30" and wider

Width	Right Hinged	Left Hinged	# of Doors
15"	198P022	198P222	1
18"	118P022	118P222	1
24"	128P022	128P222	1
30"	138P022	-	2
36"	148P022	-	2
42"	188P022	-	2
48"	158P022	-	2
513mm	168P022	168P222	1
1000mm	178P022	-	2

**Note 2:**

- Pump Storage Cabinets with a false panel are insulated with sound absorption foam for noise reduction.
- Vent hose connection is located on the rear of these cabinets.
- Cabinets are supplied with switch and outlet pre-wired to junction box on back panel.
- Switch shown on the false panel controls interior 120V/20amp,(15amp in Canada) duplex receptacle for remote ON/OFF control. Duplex and cover plate are black.
- These units include a pull-out tray and removable access panel at the back of the cabinet.
- Add Option Code PF for optional pump cabinet fan.
- Vibration isolators are available, contact Mott for details.
- Fan information: 115 VAC  
120 X 120 X 38mm  
81 CFM

Option Code
NFD

- NFD option can be applied on all Pump Storage Cabinets with full height doors and false panel units.
- Pump cabinet with no floor, toe kick integral to the door and dolly with 1" high lip with swivel casters with brake.
- Roll-out dolly to match material of cabinet.

Option Code
NF

- NF option can be applied on all Pump Storage Cabinets with full height doors and false panel units.
- Pump cabinet with no floor and toe kick integral to the door.



False Panel Unit with NFD Option Shown

*STEEL CASEWORK  
SPECIALTY CABINETS - STANDING HEIGHT*

**Glassware Drying Unit (22" Deep)**

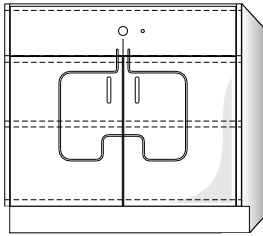
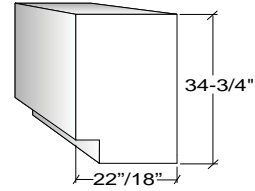

Width	Item Number	# of Doors
30"	1310822	2
36"	1410822	2
42"	1810822	2
48"	1510822	2
1000mm	1710822	2

- Glassware Drying Units have double wall insulated construction.
- These units include one perforated stainless steel shelf, stainless steel drip tray in cabinet bottom, a pilot light and 750 watt heating element with adjustable temperature up to 80° C / 176° F.
- The controls are removable for easy element replacement from front of cabinet.
- Operates on 110V, AC with a grounded cord. Includes 6' of electrical cord with NEMA 5-15P.

**Glassware Drying Unit (18" Deep)**

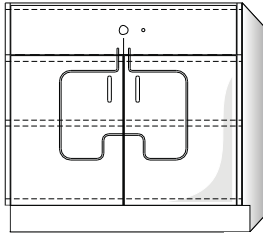

Width	Item Number	# of Doors
30"	1330822	2
36"	1430822	2
42"	1830822	2
48"	1530822	2
1000mm	1730822	2

- Glassware Drying Units have double wall insulated construction.
- These units include one perforated stainless steel shelf, stainless steel drip tray in cabinet bottom, a pilot light and 750 watt heating element with adjustable temperature up to 80° C / 176° F.
- The controls are removable for easy element replacement from front of cabinet.
- Operates on 110V, AC with a grounded cord. Includes 6' of electrical cord with NEMA 5-15P.

*SPECIALTY CABINETS - ADA HEIGHT*

**Glassware Drying Unit (22" Deep)**

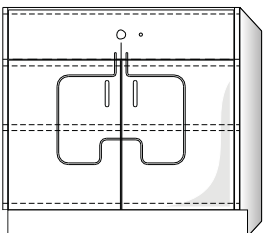
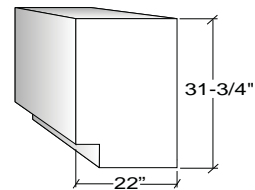

Width	Item Number	# of Doors
30"	1380822	2
36"	1480822	2
42"	1880822	2
48"	1580822	2
1000mm	1780822	2

- Glassware Drying Units have double wall insulated construction.
- These units include one perforated stainless steel shelf, stainless steel drip tray in cabinet bottom, a pilot light and 750 watt heating element with adjustable temperature up to 80° C / 176° F.
- The controls are removable for easy element replacement from front of cabinet.
- Operates on 110V, AC with a grounded cord. Includes 6' of electrical cord with NEMA 5-15P.



*STEEL CASEWORK  
SPECIALTY WALL CABINETS*

**Double Door Security Cabinets (8" Deep)**

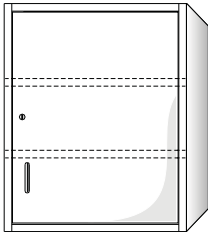
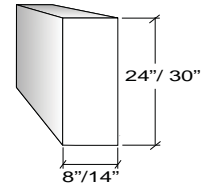

Width	Right Hinged	Left Hinged	Height
15"	5700260	5701260	24"
18"	5100260	5101260	24"
24"	5200260	5201260	24"
15"	5790260	5791260	30"
18"	5190260	5191260	30"
24"	5290260	5291260	30"

- Double door cabinet complete with locks on both doors.
- Inside lock is keyed separately from outside lock.
- Shelves adjustable in 1/2" increments.
- Add option code RL to order the optional remote LED light that indicates the door is unlocked.

**Double Door Security Cabinets (14" Deep)**

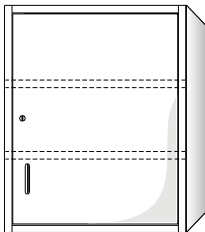

Width	Right Hinged	Left Hinged	Height
15"	5770260	5771260	24"
18"	5170260	5171260	24"
24"	5270260	5271260	24"
15"	5710260	5711260	30"
18"	5110260	5111260	30"
24"	5210260	5211260	30"

- Double door cabinet complete with locks on both doors.
- Inside lock is keyed separately from outside lock.
- Shelves adjustable in 1/2" increments.
- Add option code RL to order the optional remote LED light that indicates the door is unlocked.

**Goggle Cabinet (10-1/2" Deep)**

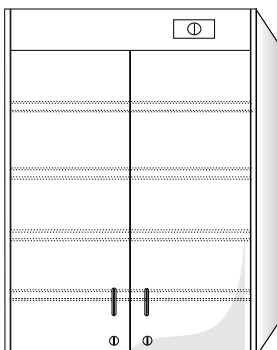
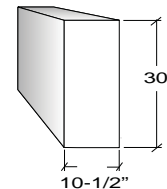

Width	Item Number
24"	52C0260

- Goggle cabinets expose safety goggles to germicidal ultraviolet light.
- When the doors are closed and locked, the inside of the cabinet is flooded with germicidal ultra violet light. A safety interlock device automatically shuts off the ultraviolet light when the doors are opened.
- Dimensions: 24" (60.96cm) Wide, 30" (76.2cm) High, 10-1/2" (26.67cm) Deep.
- Cabinet can be mounted on a wall or table and includes two safety door switches and key locks.
- Holds 30 pairs of goggles (not included).
- Operates on 110V, AC with a grounded cord. Includes 6' of electrical cord with NEMA 5-15P.
- Cabinet is ONLY available in Bright White #693226.



*STEEL CASEWORK  
SPECIALTY RECESSED OPERATING ROOM CABINETS*

**Operating Room Cabinet Features and Plan View**

**Construction Features:**

- Hospital operating room storage consoles are arranged to accommodate the individual needs of the end user.
- Powder coated steel construction. Also available in type 304 stainless steel with a #4 finish, or 316 stainless steel with a #4 finish.
- All exposed welds are ground and polished to match a #4 finish.
- Three shelves supplied with the cabinet, adjustable in 1/2" increments.
- Units with glass doors are supplied with 6mm laminated safety glass.

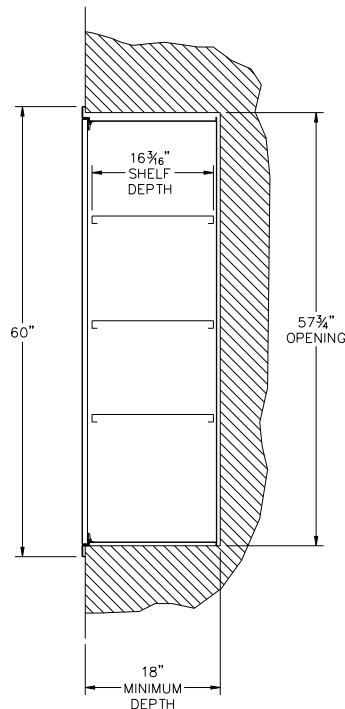
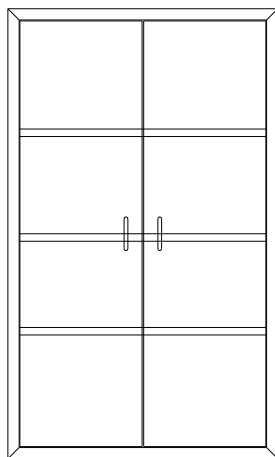
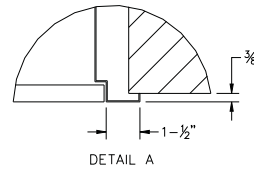
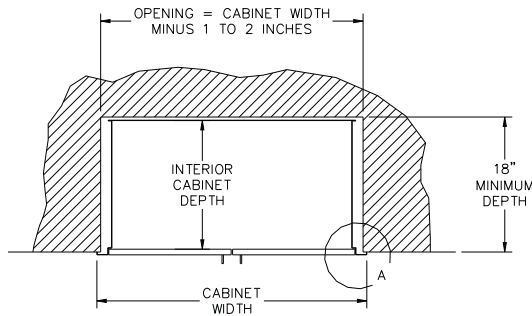

*STEEL CASEWORK  
SPECIALTY RECESSED OPERATING ROOM CABINETS*

**Hinged Framed Door Units (18" Deep)**

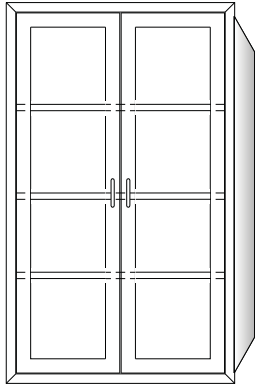
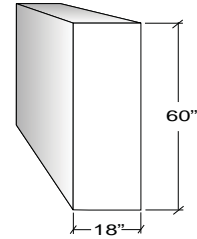

Width	Right Hinged	Left Hinged	# of Doors
18"	4170030	4170230	1
24"	4270030	4270230	1
30"	4370030	-	2
36"	4470030	-	2
42"	4670030	-	2
48"	4570030	-	2

**Hinged Door Units (18" Deep)**

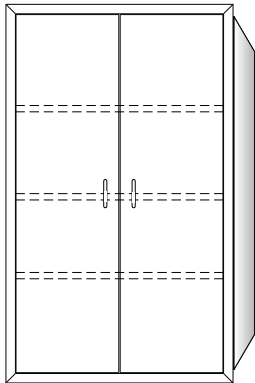

Width	Right Hinged	Left Hinged	# of Doors
18"	4170060	4170260	1
24"	4270060	4270260	1
30"	4370060	-	2
36"	4470060	-	2
42"	4670060	-	2
48"	4570060	-	2

**Drawer Desk Units (18" Deep)**

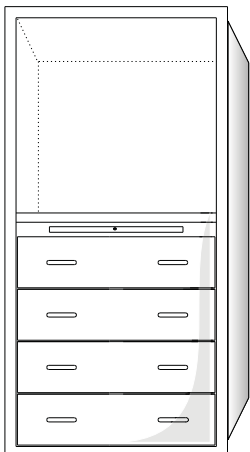

Width	Item Number
18"	4176000
24"	4276000
30"	4376000
36"	4476000
42"	4676000
48"	4576000

- These units include one metal pullout writing board.
- Add option code DL for a fluorescent light.

*STEEL CASEWORK  
SPECIALTY RECESSED OPERATING ROOM CABINETS*

**Recessed Cabinet Joint**

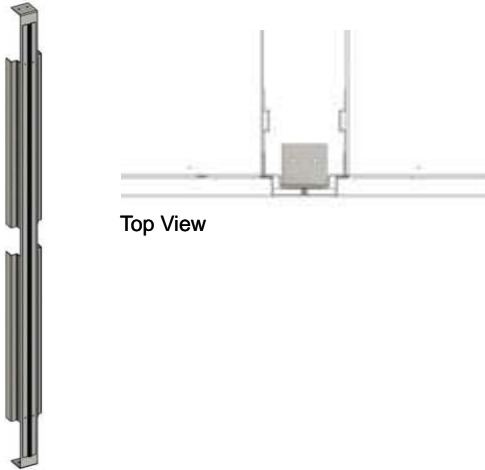

Top View

<b>Item Number</b>
4070000

- 57-3/4" High
- Used to join two Recessed Cabinets side by side.

*STEEL CASEWORK  
SPECIALTY STAINLESS STEEL CABINETS*

**Sigma Seal™ Units (34-3/4" High)**

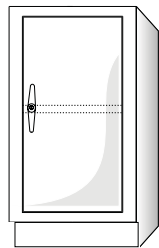
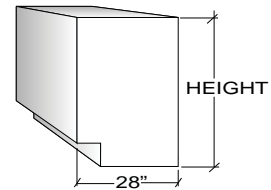

up to 24" wide

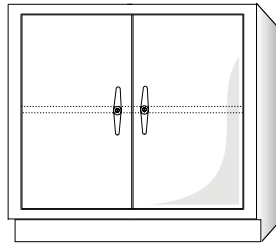

30" and wider

Width	Right Hinged	Left Hinged	# of Doors
18"	11B0011	11B0211	1
24"	12B0011	12B0211	1
30"	13B0011	-	2
36"	14B0011	-	2
42"	18B0011	-	2
48"	15B0011	-	2
513mm	16B0011	16B0211	1

- All stainless steel construction.
- Doors include gasket.
- Front of units are water tight for wash down applications.

**Sigma Seal™ Units (28-3/4" High)**

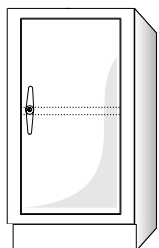

up to 24" wide

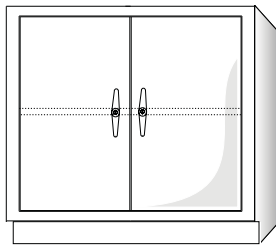

30" and wider

Width	Right Hinged	Left Hinged	# of Doors
18"	11C0011	11C0211	1
24"	12C0011	12C0211	1
30"	13C0011	-	2
36"	14C0011	-	2
42"	18C0011	-	2
48"	15C0011	-	2
513mm	16C0011	16C0211	1

- All stainless steel construction.
- Doors include gasket.
- Front of units are water tight for wash down applications.

*STEEL CASEWORK  
SPECIALTY CABINET DETAILS*

**Acid Cabinet Vent Hole Location**

Acid cabinets are lined with a chemically resistant molded polyethylene liner (molded liners are removable). 3/16" thick fiberglass reinforced polyester lined cabinets are an available option. Removable liner is held in place with capped stainless steel screws and has a vent connection. Each cabinet has one black phenolic shelf. Cabinets are marked "ACID" - in red

**Note:** Acid Cabinets must be vented. Mott recommends venting acid cabinets with a Polyolefin Vent Kit (PVSS for Molded Tub liner cabinets or PVSA for FRP liner cabinets - see page P52). Vent location applies to 28-3/4", 31-3/4", 34-3/4", 44" and 65" height cabinets.

2"DIA Female National Pipe Thread vent connection on cabinets with Molded Tub Liners and 1-1/2" Plain Hole on cabinets with FRP Liners.

Vent hole location for all **SINGLE DOOR** Acid Cabinets

Vent hole location for all **DOUBLE DOOR** Acid Cabinets

**Acid Cabinet Rear View**

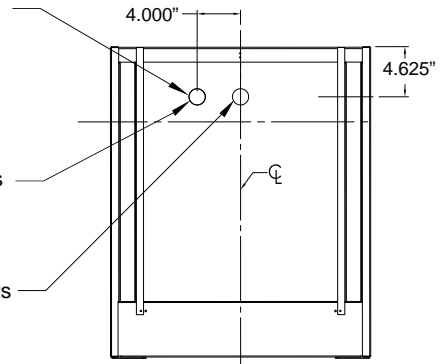

**Solvent Cabinet Vent Hole Location**

Insulated Solvent Storage cabinets are fabricated with a 2" insulated double wall and are approved to UL1275, and meet National Fire Protection Association standards. The floor of the cabinet has a 2" deep liquid tight spill containment pan. Doors are mounted on continuous hinges with a three point locking self latching handle. Optional self closing doors and self closing/latching doors with a fusible link are also available. Each cabinet has two 2" diameter vents in the rear of the cabinet, complete with flame arrestor and vent covers. Each cabinet has one powder coated steel shelf. Cabinets are marked "FLAMMABLE KEEP FIRE AWAY" - in red letters.

Uninsulated safety cabinets that meet National Fire Protection Association standards are also available.

**Note:** Fire code does not require Solvent Cabinets to be vented. Do not vent Solvent Cabinets to fume hood. If cabinet must be vented use fireproof pipe. Contact Mott for details. Vent location applies to 28-3/4", 31-3/4", 34-3/4", 44" and 65" height cabinets.

2"DIA Female National Pipe Thread in two places as shown

**Solvent Cabinet Rear View**

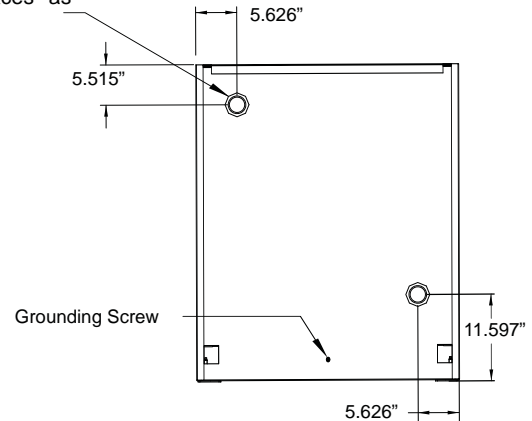

**Pump Storage Cabinet Vent Hole Location**

Pump cabinets are insulated with 1" thick acoustic foam which provides sound absorption and noise reduction over a wide range of frequencies. Foam is incorporated to the interior of the cabinet including the door and it is contained with a mechanical inner steel frame. The foam is fire resistant and complies with MVSS 302 AND UI94 HF-1 requirements. Two vent holes are incorporated into the cabinet back for connections to centralized lab exhaust systems. Custom vent cutouts are available. Back access panel is easily removable to provide convenient access to venting or electrical connections after installation. One 120 Volt / 20 Amp (15 Amp in Canada) electrical duplex receptacle provides power to the vacuum pump (final power connection required). The switch that controls receptacles is located on the front panel on False Panel Units; Full height Door Units are typically wired through the fume hood.

**Pump Storage Cabinet Rear**

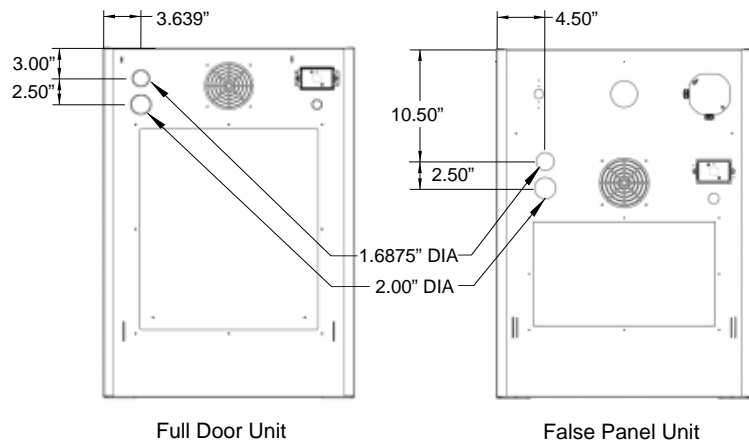

*STEEL CASEWORK  
SUSPENDED CABINETS*

**Open Units**

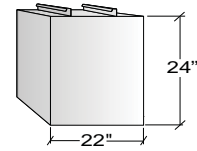

**Note:** Add Option Code 15 to order a finished back on these units.

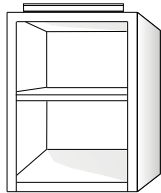

Width	Item Number
15"	1950000
18"	1150000
24"	1250000
30"	1350000
36"	1450000
42"	1850000
48"	1550000
513mm	1650000
1000mm	1750000

**Full Door Units**

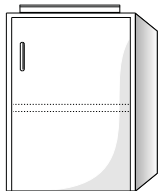

up to 24" wide

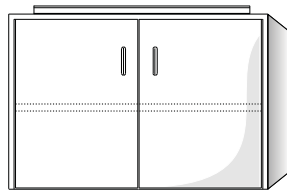

30" and wider

Width	Right Hinged	Left Hinged	# of Doors
15"	1950011	1950211	1
18"	1150011	1150211	1
24"	1250011	1250211	1
30"	1350011	-	2
36"	1450011	-	2
42"	1850011	-	2
48"	1550011	-	2
513mm	1650011	1650211	1
1000mm	1750011	-	2

**Door/Drawer Units**

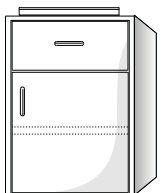

up to 24" wide

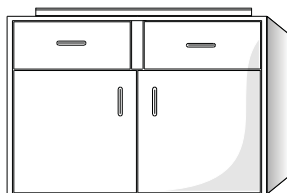

30" and wider

Width	Right Hinged	Left Hinged	# of Doors
15"	1950022	1950222	1
18"	1150022	1150222	1
24"	1250022	1250222	1
30"	1350022	-	2
36"	1450022	-	2
42"	1850022	-	2
48"	1550022	-	2
513mm	1650022	1650222	1
1000mm	1750022	-	2

- Cabinets up to 24" wide receive one shelf.
- Cabinets 25" and wider do not have a shelf.

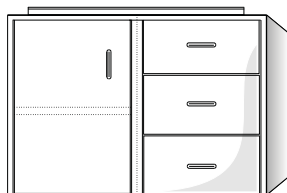

Width	Left Hand	Right Hand
30"	1350014	1350041
36"	1450014	1450041
42"	1850014	1850041
48"	1550014	1550041
1000mm	1750014	1750041

- Left hand Door/Drawer Unit shown.
- Right hand Door/Drawer Units are reverse of what is shown.

*STEEL CASEWORK  
SUSPENDED CABINETS*

**Drawer Units**

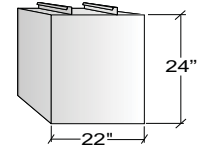

**Note:** Add Option Code 15 to order a finished back on these units.



up to 24" wide



30" and wider

Width	Item Number
15"	1950044
18"	1150044
24"	1250044
30"	1350044
36"	1450044
42"	1850044
48"	1550044
513mm	1650044
1000mm	1750044



up to 24" wide



30" and wider

Width	Item Number
15"	1950055
18"	1150055
24"	1250055
30"	1350055
36"	1450055
42"	1850055
48"	1550055
513mm	1650055
1000mm	1750055



up to 24" wide



30" and wider

Width	Item Number
15"	1950066
18"	1150066
24"	1250066
30"	1350066
36"	1450066
42"	1850066
48"	1550066
513mm	1650066
1000mm	1750066

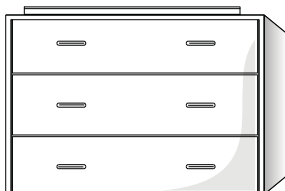

Width	Item Number
30"	1350097
36"	1450097
42"	1850097
48"	1550097
1000mm	1750097

*STEEL CASEWORK  
SUSPENDED CABINETS*

**Drawer Units**

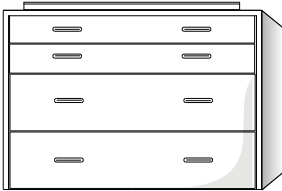

Width	Item Number
30"	1350098
36"	1450098
42"	1850098
48"	1550098
1000mm	1750098

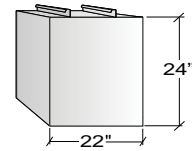

**Note:** Add Option Code 15 to order a finished back on these units.

**File Drawer Units**



up to 24" wide

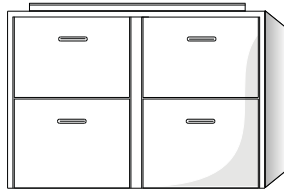

30" and wider

Width	Item Number
15"	1950122
18"	1150122
24"	1250122
30"	1350122
36"	1450122
42"	1850122
48"	1550122
513mm	1650122
1000mm	1750122



up to 24" wide



30" and wider

Width	Item Number
15"	1950177
18"	1150177
24"	1250177
30"	1350177
36"	1450177
42"	1850177
48"	1550177
513mm	1650177
1000mm	1750177



up to 24" wide



30" and wider

Width	Item Number
15"	1950188
18"	1150188
24"	1250188
30"	1350188
36"	1450188
42"	1850188
48"	1550188
513mm	1650188
1000mm	1750188

*STEEL CASEWORK  
SUSPENDED CABINETS*

**Sliding Door Units**

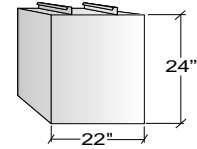

**Note:** Add Option Code 15 to order a finished back on these units.

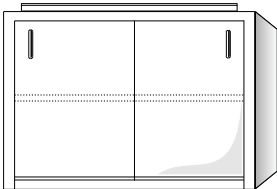

Width	Item Number
30"	1350711
36"	1450711
42"	1850711
48"	1550711
1000mm	1750711

**Sink Units**

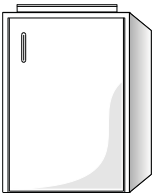

up to 24" wide

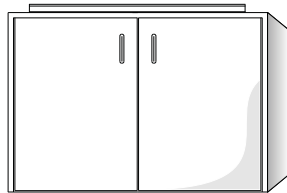

30" and wider

Width	Right Hinged	Left Hinged	# of Doors
15"	1953011	1953211	1
18"	1153011	1153211	1
24"	1253011	1253211	1
30"	1353011	-	2
36"	1453011	-	2
42"	1853011	-	2
48"	1553011	-	2
513mm	1653011	1653211	1
1000mm	1753011	-	2

**Acid Storage Units**

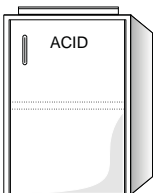

up to 24" wide

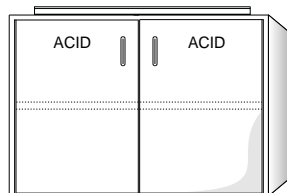

30" and wider

Width	Right Hinged	Left Hinged	# of Doors
15"	1951011	1951211	1
18"	1151011	1151211	1
24"	1251011	1251211	1
30"	1351011	-	2
36"	1451011	-	2
42"	1851011	-	2
48"	1551011	-	2
513mm	1651011	1651211	1
1000mm	1751011	-	2

• Acid Storage Units have a FRP liner.

**Solvent Storage Units**

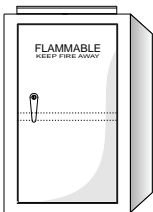

up to 24" wide

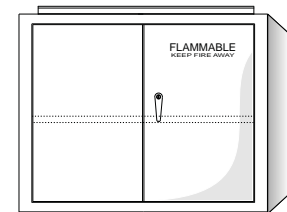

30" and wider

Width	Right Hinged	Left Hinged	# of Doors
15"	1952211	1952311	1
18"	1152211	1152311	1
24"	1252211	1252311	1
30"	1352211	-	2
36"	1452211	-	2
42"	1852211	-	2
48"	1552211	-	2
513mm	1652211	1652311	1
1000mm	1752211	-	2

- Solvent Units are not insulated.
- Add Option code 83 to order Self Closing/Latching doors.
- Add Option Code "FL" to order self closing/latching doors with a fusible link.
- Solvent Units are designed to meet OSHA and NFPA 30 standards.

**QUALITY BY DESIGN**



*STEEL CASEWORK  
SUSPENDED CABINETS*

**Open Units**

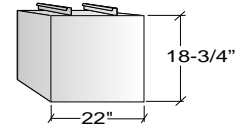

**Note:** Add Option Code 15 to order a finished back on these units.

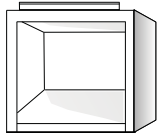

Width	Item Number
15"	1960000
18"	1160000
24"	1260000
30"	1360000
36"	1460000
42"	1860000
48"	1560000
513mm	1660000
1000mm	1760000

**Full Door Unit**

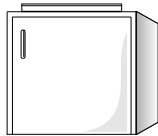

up to 24" wide

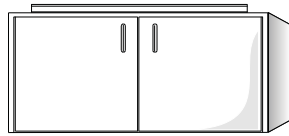

30" and wider

Width	Right Hinged	Left Hinged	# of Doors
15"	1960011	1960211	1
18"	1160011	1160211	1
24"	1260011	1260211	1
30"	1360011	-	2
36"	1460011	-	2
42"	1860011	-	2
48"	1560011	-	2
513mm	1660011	1660211	1
1000mm	1760011	-	2

**Door/Drawer Units**



up to 24" wide

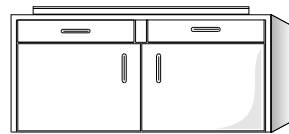

30" and wider

Width	Right Hinged	Left Hinged	# of Doors
15"	1960022	1960222	1
18"	1160022	1160222	1
24"	1260022	1260222	1
30"	1360022	-	2
36"	1460022	-	2
42"	1860022	-	2
48"	1560022	-	2
513mm	1660022	1660222	1
1000mm	1760022	-	2

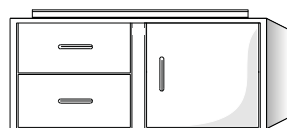

Width	Item Number
30"	1360041
36"	1460041
42"	1860041
48"	1560041
1000mm	1760041

*STEEL CASEWORK  
SUSPENDED CABINETS*

**Drawer Units**

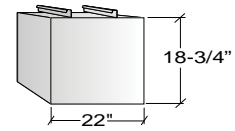

**Note:** Add Option Code 15 to order a finished back on these units.



up to 24" wide



30" and wider

Width	Item Number
15"	1960044
18"	1160044
24"	1260044
30"	1360044
36"	1460044
42"	1860044
48"	1560044
513mm	1660044
1000mm	1760044

**File Drawer Units**

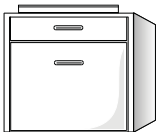

up to 24" wide



30" and wider

Width	Item Number
15"	1960177
18"	1160177
24"	1260177
30"	1360177
36"	1460177
42"	1860177
48"	1560177
513mm	1660177
1000mm	1760177

**Sink Units**

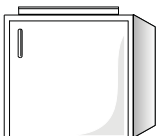

up to 24" wide

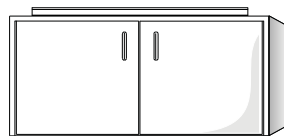

30" and wider

Width	Right Hinged	Left Hinged	# of Doors
15"	1963011	1963211	1
18"	1163011	1163211	1
24"	1263011	1263211	1
30"	1363011	-	2
36"	1463011	-	2
42"	1863011	-	2
48"	1563011	-	2
513mm	1663011	1663211	1
1000mm	1763011	-	2

*STEEL CASEWORK  
MISCELLANEOUS ITEMS - SUSPENDED COMPONENTS*

**Pencil Drawers**



Width	Item Number
15"	PEN0015
18"	PEN0018
20"	PEN0020
24"	PEN0024
30"	PEN0030

- Pencil Drawer suspends from tables with hanging rails.
- Drawer on Pencil Drawer is supplied with full extension runners.
- When ordering a table with aprons add option code HU to suspend Pencil Drawer.

**Pull Out Writing Tablet**



Width	Item Number
15"	PUL0015
18"	PUL0018
20"	PUL0020
24"	PUL0024
30"	PUL0030

- Pull Out Writing Tablet suspends from tables with hanging rails.
- Pull Out Writing Tablet is supplied with full extension runners.
- When ordering a table with aprons add option code HU to suspend Pull Out Writing Tablet.

**Hanging CPU Holder**

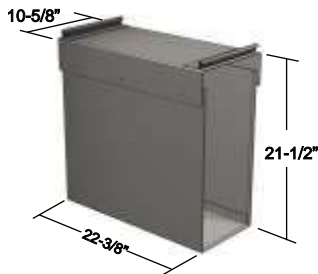

Item Number
CPU1010

- Suspends from tables with hanging rails and is supplied with full extension runners to slide out CPU unit.
- Inside clear dimension of CPU holder is 9-3/16".
- Hanging CPU Holder does not fit on a 22" deep table.
- When ordering a table with aprons add option code HU to suspend CPU holder.

*STEEL CASEWORK  
MISCELLANEOUS ITEMS - BASE FILLER PANELS*

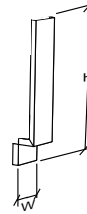

**Front Filler Scribes - Standing Height**

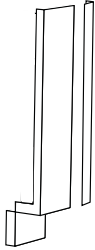

- The Front Filler Scribe is used to close a space between a base cabinet and a wall.
- A double angle is provided to enclose the raw edge of the panel.
- Filler panels can be ordered in 1" increments, up to 24" wide. Change the last two digits to the dimension required.
- 34-3/4" high right hand shown.

Width	Right Hand	Left Hand
1"	FFR1001	FFL1001
2"	FFR1002	FFL1002
4"	FFR1004	FFL1004
6"	FFR1006	FFL1006
8"	FFR1008	FFL1008
10"	FFR1010	FFL1010
12"	FFR1012	FFL1012

- Use option code "OL" when ordering Architectural Overlay design.

**Front Filler Scribes - Sitting Height**

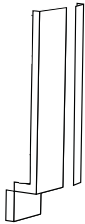

- The Front Filler Scribe is used to close a space between a base cabinet and a wall.
- A double angle is provided to enclose the raw edge of the panel.
- Filler panels can be ordered in 1" increments, up to 24" wide. Change the last two digits to the dimension required.
- 28-3/4" high right hand shown.

Width	Right Hand	Left Hand
1"	FFR2001	FFL2001
2"	FFR2002	FFL2002
4"	FFR2004	FFL2004
6"	FFR2006	FFL2006
8"	FFR2008	FFL2008
10"	FFR2010	FFL2010
12"	FFR2012	FFL2012

- Use option code "OL" when ordering Architectural Overlay design.

**Front Filler Scribes - ADA Height**



- The Front Filler Scribe is used to close a space between a base cabinet and a wall.
- A double angle is provided to enclose the raw edge of the panel.
- Filler panels can be ordered in 1" increments, up to 24" wide. Change the last two digits to the dimension required.
- 31-3/4" high right hand shown.

Width	Right Hand	Left Hand
1"	FFR8001	FFL8001
2"	FFR8002	FFL8002
4"	FFR8004	FFL8004
6"	FFR8006	FFL8006
8"	FFR8008	FFL8008
10"	FFR8010	FFL8010
12"	FFR8012	FFL8012

- Use option code "OL" when ordering Architectural Overlay design.

**Front Filler Panels**



- The Front Filler Panel is used to close a space between two base cabinets.
- Available in sitting height (28-3/4"), ADA height (31-3/4") and standing height (34-3/4").
- Filler panels can be ordered in 1" increments, up to 24" wide. Change the last two digits to the dimension required.

Width	Sitting Hgt	Standing Hgt	ADA Hgt
1"	FFC2001	FFC1001	FFC8001
2"	FFC2002	FFC1002	FFC8002
4"	FFC2004	FFC1004	FFC8004
6"	FFC2006	FFC1006	FFC8006
8"	FFC2008	FFC1008	FFC8008
10"	FFC2010	FFC1010	FFC8010
12"	FFC2012	FFC1012	FFC8012
24"	FFC2024	FFC1024	FFC8024

- Use option code "OL" when ordering Architectural Overlay design.

**Corner Filler Panels**

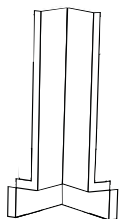

- The Corner Filler Panel is used to close a corner space between two base cabinets.
- Available in sitting height (28-3/4"), ADA height (31-3/4") and standing height (34-3/4").
- Filler panels can be ordered in 1" increments, up to 24" wide. Change the last two digits to the dimension required.

Width	Sitting Hgt	Standing Hgt	ADA Hgt
1" x 1"	CFC2001	CFC1001	CFC8001
2" x 2"	CFC2002	CFC1002	CFC8002
4" x 4"	CFC2004	CFC1004	CFC8004
6" x 6"	CFC2006	CFC1006	CFC8006

- Use option code "OL" when ordering Architectural Overlay design.

*STEEL CASEWORK  
MISCELLANEOUS ITEMS - BASE FILLER PANELS*

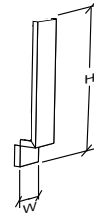

**Corner Filler Panel Scribes**

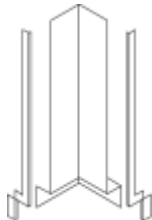

- The Corner Filler Panel is used to close a corner space between two base cabinets.
- Two double angles are provided to enclose the raw edges of the panel.
- Available in sitting height (28-3/4"), ADA height (31-3/4") and standing height (34-3/4").
- Use option code "OL" when ordering Architectural Overlay design.

Width	Sitting Hgt	Standing Hgt	ADA Hgt
3" x 3"	CFS2003	CFS1003	CFS8003
6" x 6"	CFS2006	CFS1006	CFS8006

**Adjustable Corner Fillers**

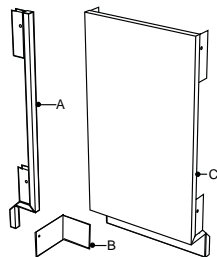

- The items A, B, & C combine to make the Adjustable Corner Filler Panel.
- This panel is used to close a corner space between two base cabinets. It offers the added advantage of being adjustable to enclose spaces up to 14" wide.
- Available in sitting height (28-3/4"), ADA height (31-3/4") and standing height (34-3/4").
- Use option code "OL" when ordering Architectural Overlay design.

Height	Item A	Item B	Item C
28-3/4"	FFC2001	9900001	FFC2018
34-3/4"	FFC1001	9900001	FFC1018
31-3/4"	FFC8001	9900001	FFC8018

**End Cover Panel Scribes**

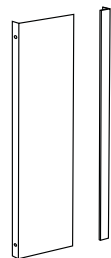

- The End Cover Panel Scribes are used to close spaces between the back of a base cabinet and a wall. The Scribe feature allows for easy width adjustment in the field.
- Filler panels can be ordered in 1" increments, up to 24" wide. Change the last two digits to the dimension required.
- Available in sitting height (28-3/4"), ADA height (31-3/4") and standing height (34-3/4").

Width	Sitting Hgt	Standing Hgt	ADA Hgt
1"	ECS2001	ECS1001	ECS5001
4"	ECS2004	ECS1004	ECS5004
7"	ECS2007	ECS1007	ECS5007
8"	ECS2008	ECS1008	ECS5008
10"	ECS2010	ECS1010	ECS5010
11"	ECS2011	ECS1011	ECS5011
120mm	ECS200A	ECS100A	ECS500A
266mm	ECS200B	ECS100B	ECS500B

**End Cover Channels**



- The End Cover Channel performs the same task as the End Cover Panel Scribe but is of a fixed width.
- Filler panels can be ordered in 1" increments, up to 24" wide. Change the last two digits to the dimension required.
- Available in sitting height (28-3/4"), ADA height (31-3/4") and standing height (34-3/4").

Width	Sitting Hgt	Standing Hgt	ADA Hgt
1"	ECC2001	ECC1001	ECC5001
2"	ECC2002	ECC1002	ECC5002
4"	ECC2004	ECC1004	ECC5004
7"	ECC2007	ECC1007	ECC5007
13"	ECC2013	ECC1013	ECC5013
14"	ECC2014	ECC1014	ECC5014
120mm	ECC200A	ECC100A	ECC500A

*STEEL CASEWORK  
MISCELLANEOUS ITEMS - PANELS & ANGLES*

**Finished Back Panels**



- The Finished Back Panels are used to close off the back of a base cabinet when the back is in plain view.
- Available in sitting height (28-3/4"), ADA height (31-3/4") or standing height (34-3/4").
- Add option code 15 for a welded back on a cabinet.
- Filler panels can be ordered in 1" increments, up to 24" wide. Change the last two digits to the dimension required.

Width	Sitting Hgt	Standing Hgt	ADA Hgt
15"	FBP2015	FBP1015	FBP6015
18"	FBP2018	FBP1018	FBP6018
24"	FBP2024	FBP1024	FBP6024
30"	FBP2030	FBP1030	FBP6030
36"	FBP2036	FBP1036	FBP6036
42"	FBP2042	FBP1042	FBP6042
48"	FBP2048	FBP1048	FBP6048

**Extended Finished Back Panels**



Width	Sitting Height		Standing Height		ADA Height	
	4" Depth	18" Depth	4" Depth	18" Depth	4" Depth	18" Depth
15"	FEC1504	FEC1518	FEA1504	FEA1518	FED1504	FED1518
18"	FEC1804	FEC1818	FEA1804	FEA1818	FED1804	FED1818
24"	FEC2404	FEC2418	FEA2404	FEA2418	FED2404	FED2418
30"	FEC3004	FEC3018	FEA3004	FEA3018	FED3004	FED3018
36"	FEC3604	FEC3618	FEA3604	FEA3618	FED3604	FED3618
42"	FEC4204	FEC4218	FEA4204	FEA4218	FED4204	FED4218
48"	FEC4804	FEC4818	FEA4804	FEA4818	FED4804	FED4818
60"	FEC6004	FEC6018	FEA6004	FEA6018	FED6004	FED6018
72"	FEC7204	FEC7218	FEA7204	FEA7218	FED7204	FED7218

- The Extended Finished Back Panels are used to close off the back of a base cabinet when the back is in plain view.
- Available in sitting height (28-3/4"), ADA height (31-3/4") or standing height (34-3/4").
- Panels are available in 1" increments from 4" - 18" Deep. Change the last two digits to the dimension required.
- Corner gussets are welded into top and bottom corners.

**Single Angles**



Length	1" x 1"	2" x 2"
28 - 1/2"	SAG110C	SAG220C
31 - 1/2"	SAG110B	SAG220B
34 - 1/2"	SAG110A	SAG220A
18"	SAG1118	SAG2218
24"	SAG1124	SAG2224
36"	SAG1136	SAG2236
48"	SAG1148	SAG2248
60"	SAG1160	SAG2260
72"	SAG1172	SAG2272
84"	SAG1184	SAG2284

**Double Angles**



Length	1" x 1"
28 - 1/2"	DAG110C
31 - 1/2"	DAG110B
34 - 1/2"	DAG110A
12"	DAG1112
24"	DAG1124
30"	DAG1130
36"	DAG1136
42"	DAG1142
48"	DAG1148
60"	DAG1160
72"	DAG1172
84"	DAG1184

*STEEL CASEWORK  
MISCELLANEOUS ITEMS - TALL FILLER PANELS*

**Tall Storage Corner Filler Scribes**



- The Tall Corner Storage Filler Panel is used to close a corner space between two floor cabinets.
- The scribe feature allows for easy width adjustment in the field.
- Two double angles are provided to enclose the raw edges of the panel.
- Use option code "OL" when ordering Architectural Overlay design.

Width	84" High
3" x 3"	CFS3003
6" x 6"	CFS3006

**Tall Filler Scribes**

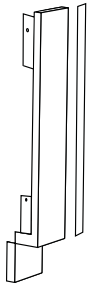

- The Tall Front Filler Scribe is used to close a space between a floor cabinet and a wall.
- A double angle is provided to enclose the raw edge of the panel.
- Filler panels can be ordered in 1" increments, up to 24" wide. Change the last two digits to the dimension required.
- 84" high right hand shown.
- Use option code "OL" when ordering Architectural Overlay design.

Width	Right Hand	Left Hand
1"	FFR3001	FFL3001
2"	FFR3002	FFL3002
4"	FFR3004	FFL3004
6"	FFR3006	FFL3006
8"	FFR3008	FFL3008
10"	FFR3010	FFL3010
12"	FFR3012	FFL3012

**Tall Front Filler Panels**



- The Tall Front Filler Panel is used to close a space between two floor cabinets.
- Filler panels can be ordered in 1" increments, up to 24" wide. Change the last two digits to the dimension required.
- 84" high.
- Use option code "OL" when ordering Architectural Overlay design.

Width	84" High
1"	FFC3001
2"	FFC3002
3"	FFC3003
4"	FFC3004
8"	FFC3008
10"	FFC3010
12"	FFC3012
24"	FFC3024

**Tall End Cover Panel Scribes**

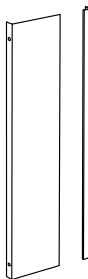

- The Tall End Cover Panel Scribes are used to close spaces between the back of a floor cabinet and a wall.
- The Scribe feature allows for easy width adjustment in the field.
- Filler panels can be ordered in 1" increments, up to 24" wide. Change the last two digits to the dimension required.
- 84" high.

Width	84" High
1"	ECS3001
2"	ECS3002
3"	ECS3003
4"	ECS3004
7"	ECS3007
8"	ECS3008

**Tall End Cover Channels**

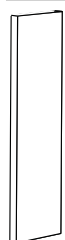

- The Tall End Cover Channel performs the same task as the End Cover Panel Scribe but is of a fixed width.
- Filler panels can be ordered in 1" increments, up to 24" wide. Change the last two digits to the dimension required.
- 84" high.

Width	84" High
1"	ECC3001
2"	ECC3002
3"	ECC3003
4"	ECC3004
7"	ECC3007
8"	ECC3008



*STEEL CASEWORK  
MISCELLANEOUS ITEMS - WALL FILLER PANELS*

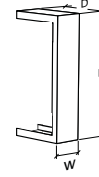

**Front Wall Filler Scribes - 14" Deep**

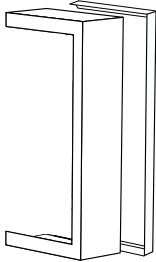

- The Wall Filler Scribe is used to close a space between a wall cabinet and a wall. It can be cut to fit gaps of various sizes.
- A double angle is provided to enclose the raw edge of the panel.
- Filler panels can be ordered in 1" increments, up to 24" wide. Change the last two digits to the dimension required.
- Filler panels can be ordered in 1" increments, up to 24" wide. Change the last two digits to the dimension required.
- Use option code "OL" when ordering Architectural Overlay design.

Width	24" High	30" High	36" High	48" High
1"	WFS5301	WFS6301	WFS7301	WFS8301
2"	WFS5302	WFS6302	WFS7302	WFS8302
3"	WFS5303	WFS6303	WFS7303	WFS8303
4"	WFS5304	WFS6304	WFS7304	WFS8304
6"	WFS5306	WFS6306	WFS7306	WFS8306
8"	WFS5308	WFS6308	WFS7308	WFS8308
10"	WFS5310	WFS6310	WFS7310	WFS8310
12"	WFS5312	WFS6312	WFS7312	WFS8312
15"	WFS5315	WFS6315	WFS7315	WFS8315
18"	WFS5318	WFS6318	WFS7318	WFS8318
24"	WFS5324	WFS6324	WFS7324	WFS8324

**Front Wall Fillers - 14" Deep**

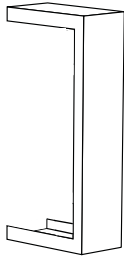

- The Wall Filler Scribe is used to close a space between two wall cabinets.
- Filler panels can be ordered in 1" increments, up to 24" wide. Change the last two digits to the dimension required.
- Use option code "OL" when ordering Architectural Overlay design.

Width	24" High	30" High	36" High	48" High
1"	WFP5301	WFP6301	WFP7301	WFP8301
2"	WFP5302	WFP6302	WFP7302	WFP8302
3"	WFP5303	WFP6303	WFP7303	WFP8303
4"	WFP5304	WFP6304	WFP7304	WFP8304
6"	WFP5306	WFP6306	WFP7306	WFP8306
8"	WFP5308	WFP6308	WFP7308	WFP8308
10"	WFP5310	WFP6310	WFP7310	WFP8310
12"	WFP5312	WFP6312	WFP7312	WFP8312
15"	WFP5315	WFP6315	WFP7315	WFP8315
18"	WFP5318	WFP6318	WFP7318	WFP8318
24"	WFP5324	WFP6324	WFP7324	WFP8324

**Front Wall Filler Scribes - 18" Deep**

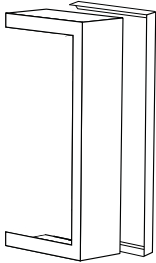

- The Wall Filler Scribe is used to close a space between a wall cabinet and a wall. It can be cut to fit gaps of various sizes.
- A double angle is provided to enclose the raw edge of the panel.
- Filler panels can be ordered in 1" increments, up to 24" wide. Change the last two digits to the dimension required.
- Use option code "OL" when ordering Architectural Overlay design.

Width	24" High	30" High	36" High	48" High
1"	WFS5201	WFS6201	WFS7201	WFS8201
2"	WFS5202	WFS6202	WFS7202	WFS8202
3"	WFS5203	WFS6203	WFS7203	WFS8203
4"	WFS5204	WFS6204	WFS7204	WFS8204
6"	WFS5206	WFS6206	WFS7206	WFS8206
8"	WFS5208	WFS6208	WFS7208	WFS8208
10"	WFS5210	WFS6210	WFS7210	WFS8210
12"	WFS5212	WFS6212	WFS7212	WFS8212
18"	WFS5218	WFS6218	WFS7218	WFS8218
19"	WFS5219	WFS6219	WFS7219	WFS8219
24"	WFS5224	WFS6224	WFS7224	WFS8224

**Front Wall Fillers - 18" Deep**

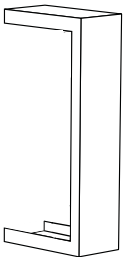

- The Wall Filler Scribe is used to close a space between two wall cabinets.
- Filler panels can be ordered in 1" increments, up to 24" wide. Change the last two digits to the dimension required.
- Use option code "OL" when ordering Architectural Overlay design.

Width	24" High	30" High	36" High	48" High
1"	WFP5201	WFP6201	WFP7201	WFP8201
2"	WFP5202	WFP6202	WFP7202	WFP8202
3"	WFP5203	WFP6203	WFP7203	WFP8203
4"	WFP5204	WFP6204	WFP7204	WFP8204
6"	WFP5206	WFP6206	WFP7206	WFP8206
8"	WFP5208	WFP6208	WFP7208	WFP8208
10"	WFP5210	WFP6210	WFP7210	WFP8210
12"	WFP5212	WFP6212	WFP7212	WFP8212
18"	WFP5218	WFP6218	WFP7218	WFP8218
19"	WFP5219	WFP6219	WFP7219	WFP8219
24"	WFP5224	WFP6224	WFP7224	WFP8224



### STEEL CASEWORK MISCELLANEOUS ITEMS - DUST CAPS

#### Sloping Dust Caps

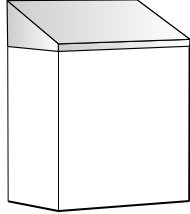

- The Sloping Dust Caps are used as a housekeeping aid on top of wall and floor cabinets.
- 8-3/8" high.

#### Overlay Corner Dust Caps

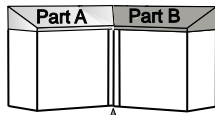

Front Wall Fillers

- The Overlay Corner Dust Caps are designed to close the corner space left by two wall cabinets. They are used in conjunction with a Sloping Dust Cap.
- 8-3/8" high.
- Order Overlay Corner Dust Cap based on cabinet width. Extra long sloping dust cap required see below to order.
- Cabinets must be equal depth.
- Order Front Wall Filler (WFP or WFS) in conjunction with an Overlay Corner Dust Cap.
- When ordering Overlay Corner Dust Caps, always use left hand (Part A) side to be the corner overlaying dust cap.

Top View Shown

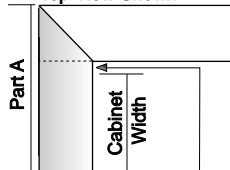

1" Front Wall Filler (WFS or WFP)

Top View Shown

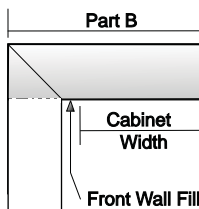

- Order Overlay Corner Dust Cap based on cabinet width. Extra long Sloping Dust Cap required.

#### Corner Wall Cabinet Dust Caps

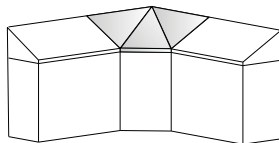

- The Corner Wall Cabinet Dust Caps are used as a housekeeping aid on top of Corner Wall Cabinets.
- 8-3/8" high.

#### Sloping Dust Cap Scribes



- The scribe feature allows for easy width adjustment in the field.
- 8-3/8" high.
- Sloping Dust Caps comes with two ECS Clips.

Right hand shown.

Width	14" Deep	18" Deep	22" Deep
15"	SDC0315	SDC0215	SDC0115
18"	SDC0318	SDC0218	SDC0118
24"	SDC0324	SDC0224	SDC0124
30"	SDC0330	SDC0230	SDC0130
36"	SDC0336	SDC0236	SDC0136
42"	SDC0342	SDC0242	SDC0142
48"	SDC0348	SDC0248	SDC0148
60"	SDC0360	SDC0260	SDC0160
72"	SDC0372	SDC0272	SDC0172
513mm	SDC030A	SDC020A	SDC010A
1000mm	SDC030B	SDC020B	SDC010B

Part A			
Cabinet Width	14" Deep	18" Deep	22" Deep
15"	CDL0315	CDL0215	CDL0115
18"	CDL0318	CDL0218	CDL0118
24"	CDL0324	CDL0224	CDL0124
30"	CDL0330	CDL0230	CDL0130
36"	CDL0336	CDL0236	CDL0136
42"	CDL0342	CDL0242	CDL0142
48"	CDL0348	CDL0248	CDL0148
60"	CDL0360	CDL0260	CDL0160
72"	CDL0372	CDL0272	CDL0172
513mm	CDL030A	CDL020A	CDL010A
1000mm	CDL030B	CDL020B	CDL010B

Part B			
Cabinet Width	14" Deep	18" Deep	22" Deep
15"	CDR0315	CDR0215	CDR0115
18"	CDR0318	CDR0218	CDR0118
24"	CDR0324	CDR0224	CDR0124
30"	CDR0330	CDR0230	CDR0130
36"	CDR0336	CDR0236	CDR0136
42"	CDR0342	CDR0242	CDR0142
48"	CDR0348	CDR0248	CDR0148
60"	CDR0360	CDR0260	CDR0160
72"	CDR0372	CDR0272	CDR0172
513mm	CDR030A	CDR020A	CDR010A
1000mm	CDR030B	CDR020B	CDR010B

Depth	Item Number
14"	CDC0300
18"	CDC0200

Width	Right Hand			Left Hand		
	14" Deep	18" Deep	22" Deep	14" Deep	18" Deep	22" Deep
1"	SDR0301	SDR0201	SDR0101	SDL0301	SDL0201	SDL0101
2"	SDR0302	SDR0202	SDR0102	SDL0302	SDL0202	SDL0102
3"	SDR0303	SDR0203	SDR0103	SDL0303	SDL0203	SDL0103
4"	SDR0304	SDR0204	SDR0104	SDL0304	SDL0204	SDL0104
5"	SDR0305	SDR0205	SDR0105	SDL0305	SDL0205	SDL0105

*STEEL CASEWORK  
MISCELLANEOUS ITEMS - LIGHT VALANCES & PANELS*

**Light Valances**



- Left side return light valance shown. Right side return light valance is opposite of what is shown.
- 3" high.



- Light valance to be fastened to the bottom of a wall cabinet. Available with left side, right side, or both returns.
- Use 12" deep light valance for 14" deep cabinets.
- Use 16" deep light valance for 18" deep cabinets.
- Light valance returns are 2" shorter in depth than the standard depth of the cabinet, to allow for clearance of opening and closing the doors above.
- 3" high.



- Front only light valance to be fastened to the bottom of a wall cabinet.
- 3" high.

Width	Right Side Return		Left Side Return	
	12" Return	16" Return	12" Return	16" Return
18"	VPR3018	VPR4018	VPL3018	VPL4018
24"	VPR3024	VPR4024	VPL3024	VPL4024
30"	VPR3030	VPR4030	VPL3030	VPL4030
36"	VPR3036	VPR4036	VPL3036	VPL4036
42"	VPR3042	VPR4042	VPL3042	VPL4042
48"	VPR3048	VPR4048	VPL3048	VPL4048
60"	VPR3060	VPR4060	VPL3060	VPL4060
72"	VPR3072	VPR4072	VPL3072	VPL4072
96"	VPR3096	VPR4096	VPL3096	VPL4096

Width	Right & Left Side Returns	
	12" Return	16" Return
18"	VPS3018	VPS4018
24"	VPS3024	VPS4024
30"	VPS3030	VPS4030
36"	VPS3036	VPS4036
42"	VPS3042	VPS4042
48"	VPS3048	VPS4048
60"	VPS3060	VPS4060
72"	VPS3072	VPS4072
96"	VPS3096	VPS4096

Width	Front Only
18"	VPF1018
24"	VPF1024
30"	VPF1030
36"	VPF1036
42"	VPF1042
48"	VPF1048
60"	VPF1060
72"	VPF1072
96"	VPF1096

**Wall Cabinet Furring Panels**



- Wall Cabinet Furring panels are used to close off the area between the top of a wall cabinet and the ceiling.
- Furring panels have a double scribe angle at top and a 2" wide flange at bottom.
- 24" high.

Width	14" Deep	18" Deep	22" Deep
18"	FPS1018	FPS2018	FPS3018
24"	FPS1024	FPS2024	FPS3024
30"	FPS1030	FPS2030	FPS3030
36"	FPS1036	FPS2036	FPS3036
42"	FPS1042	FPS2042	FPS3042
48"	FPS1048	FPS2048	FPS3048
60"	FPS1060	FPS2060	FPS3060
72"	FPS1072	FPS2072	FPS3072
96"	FPS1096	FPS2096	FPS3096
1000mm	FPS100B	FPS200B	FPS300B

*STEEL CASEWORK  
MISCELLANEOUS ITEMS - APRONS*

**Apron Units - 22" Deep**

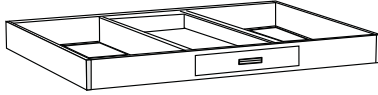

- Aprons provide a work area from a seated position.
- Aprons are available with or without drawers.
- 15" wide drawer.
- 3-3/4" high, three piece adjustable construction.
- Use option code "OL" when ordering Architectural Overlay design.

Width	Plain Front	With Drawers	# of Drawers
24"	AUC0124	AUA0124	1
30"	AUC0130	AUA0130	1
36"	AUC0136	AUA0136	1
42"	AUC0142	AUA0142	1
48"	AUC0148	AUA0148	2
54"	AUC0154	AUA0154	2
60"	AUC0160	AUA0160	2
66"	AUC0166	AUA0166	2
72"	AUC0172	AUA0172	2
513mm	AUC010A	AUA010A	1
1000mm	AUC010B	AUA010B	1

**Apron Units 28" Deep**

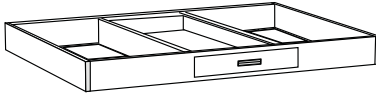

- Aprons provide a work area from a seated position.
- Aprons are available with or without drawers.
- 15" wide drawer.
- 3-3/4" high, three piece adjustable construction.
- Use option code "OL" when ordering Architectural Overlay design.

Width	Plain Front	With Drawers	# of Drawers
24"	AUC0424	AUA0424	1
30"	AUC0430	AUA0430	1
36"	AUC0436	AUA0436	1
42"	AUC0442	AUA0442	1
48"	AUC0448	AUA0448	2
54"	AUC0454	AUA0454	2
60"	AUC0460	AUA0460	2
66"	AUC0466	AUA0466	2
72"	AUC0472	AUA0472	2
513mm	AUC040A	AUA040A	1
1000mm	AUC040B	AUA040B	1

**Welded Box Aprons - 22" Deep**

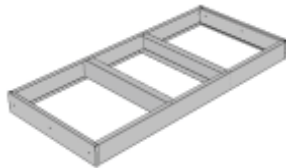

- Aprons provide a work area from a seated position.
- Aprons are available with or without drawers.
- 15" wide drawer.
- 3-3/4" high, one piece welded construction.
- Use option code "OL" when ordering Architectural Overlay design.

Width	Plain Front	With Drawers	# of Drawers
24"	BUC0124	BUA0124	1
30"	BUC0130	BUA0130	1
36"	BUC0136	BUA0136	1
42"	BUC0142	BUA0142	1
48"	BUC0148	BUA0148	2
54"	BUC0154	BUA0154	2
60"	BUC0160	BUA0160	2
66"	BUC0166	BUA0166	2
72"	BUC0172	BUA0172	2
513mm	BUC010A	BUA010A	1
1000mm	BUC010B	BUA010B	1

**Welded Box Aprons - 28" Deep**

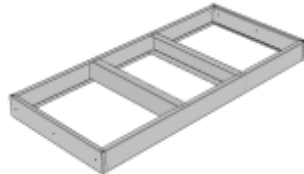

- Aprons provide a work area from a seated position.
- Aprons are available with or without drawers.
- 15" wide drawer.
- 3-3/4" high, one piece welded construction.
- Use option code "OL" when ordering Architectural Overlay design.

Width	Plain Front	With Drawers	# of Drawers
24"	BUC0424	BUA0424	1
30"	BUC0430	BUA0430	1
36"	BUC0436	BUA0436	1
42"	BUC0442	BUA0442	1
48"	BUC0448	BUA0448	2
54"	BUC0454	BUA0454	2
60"	BUC0460	BUA0460	2
66"	BUC0466	BUA0466	2
72"	BUC0472	BUA0472	2
513mm	BUC040A	BUA040A	1
1000mm	BUC040B	BUA040B	1

**STEEL CASEWORK**

**MISCELLANEOUS ITEMS - APRON COVERS & FRONT RAIL SERVICE COVERS**

**Apron Service Covers**



- Apron Service Cover panels are used to conceal open spaces and services below aprons.
- Attaches to adjacent cabinets and meets the bottom of the apron.
- Assembly includes single angles for attachment to adjacent cabinets. Upper panel is removable to allow access to the services. The lower panel stays fixed in order to apply the coved base and overlapping the lower and upper panel allows to accommodate for uneven floors.
- Available for sitting height (25"), ADA height (28") and standing height (31") applications.

Width	Sitting Hgt	Standing Hgt	ADA Hgt
15"	SCP4015	SCP3015	SCP6015
18"	SCP4018	SCP3018	SCP6018
24"	SCP4024	SCP3024	SCP6024
30"	SCP4030	SCP3030	SCP6030
36"	SCP4036	SCP3036	SCP6036
42"	SCP4042	SCP3042	SCP6042
48"	SCP4048	SCP3048	SCP6048
54"	SCP4054	SCP3054	SCP3054
60"	SCP4060	SCP3060	SCP6060
66"	SCP4066	SCP3066	SCP6066
72"	SCP4072	SCP3072	SCP6072
513mm	SCP400A	SCP300A	SCP600A
1000mm	SCP400B	SCP300B	SCP600B

**Front Rails**



• 3-3/4" high.



• 2" high.

- Front Rails are commonly used to finish a space at a sitting area. They are used when a full frame apron is not required.
- In a "cut to fit" condition, use part number DAG000F for slip filler.

Width	3-3/4" High	2" High
18"	FRA0018	FRB0018
24"	FRA0024	FRB0024
30"	FRA0030	FRB0030
36"	FRA0036	FRB0036
42"	FRA0042	FRB0042
48"	FRA0048	FRB0048
54"	FRA0054	FRB0054
60"	FRA0060	FRB0060
66"	FRA0066	FRB0066
72"	FRA0072	FRB0072
513mm	FRA000A	FRB000A
1000mm	FRA000B	FRB000B

**Double Angle Sleeves**



Length	Item Number
3-3/4"	DAG000F
3"	DAG0003
2"	DAG0002

- Double Angle Sleeves are used to cover the cut edge of a "cut to fit" front rail.

**Front Rail Service Covers**



- Apron Service Cover panels are used to conceal open spaces and services below front rails.
- Attaches to adjacent cabinets and meets the bottom of the work surface.
- Assembly includes single angles for attachment to adjacent cabinets. Upper panel is removable to allow access to the services. The lower panel stays fixed in order to apply the coved base and overlapping the lower and upper panel allows to accommodate for uneven floors.
- Available in sitting height (28-3/4"), ADA height (31-3/4") and standing height (34-3/4").

Width	Sitting Hgt	Standing Hgt	ADA Hgt
15"	SCP2015	SCP1015	SCP5015
18"	SCP2018	SCP1018	SCP5018
24"	SCP2024	SCP1024	SCP5024
30"	SCP2030	SCP1030	SCP5030
36"	SCP2036	SCP1036	SCP5036
42"	SCP2042	SCP1042	SCP5042
48"	SCP2048	SCP1048	SCP5048
54"	SCP2054	SCP1054	SCP5054
60"	SCP2060	SCP1060	SCP5060
66"	SCP2066	SCP1066	SCP5066
72"	SCP2072	SCP1072	SCP5072
513mm	SCP200A	SCP100A	SCP500A
1000mm	SCP200B	SCP100B	SCP500B

*STEEL CASEWORK  
MISCELLANEOUS ITEMS - TURRET SUPPORTS*

**Box Turret Supports**

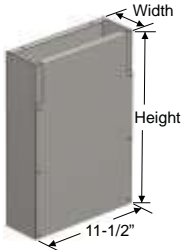

- Box Turret Supports are used to support reagent shelves. They may be used with front rails to form a rigid reagent support structure.
- The side panel is removable in order to access services.
- Counter top mounting clips are included.
- 11-1/2" deep.

Height	2" Wide	4" Wide	6" Wide
11"	9900062	9900010	9900012
17"	9900063	9900011	9900013

- Notched for a 3-3/4"H FRA rail.

Height	2" Wide	4" Wide	6" Wide
11"	9990062	9990010	9990012
17"	9990063	9990011	9990013

- Notched for a 2"H FRB rail.

**Fixed Box Turret Support**

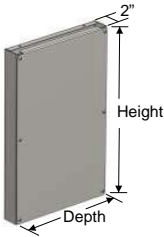

- Fixed Box Turret Supports are used to support reagent shelves. It may be used in conjunction with front rails to form a rigid reagent support structure.
- 2" wide.

Height	10" Deep	12" Deep	14" Deep	18" Deep
11"	BRS1010	BRS1012	BRS1014	BRS1018
14"	BRS2010	BRS2012	BRS2014	BRS2018
17"	BRS3010	BRS3012	BRS3014	BRS3018

**Reagent Turret Supports**

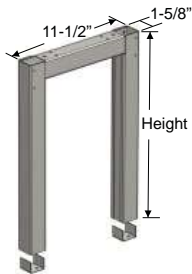

- Reagent Turret Supports are used to support reagent shelves.
- Stainless steel countertop mounting clips are included.
- 1-5/8" wide by 11-1/2" deep.

Height	Item Number
11"	9900006
17"	9900007
18"	9900008
19"	9900009

**Adjustable Box Turret Supports**

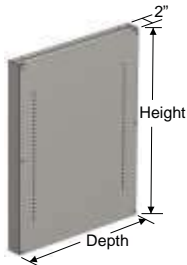

- Adjustable Box Turret End Supports are used to support reagent shelves. It may be used in conjunction with front rails to form a rigid reagent support structure.
- Adjustable slots are provided on one side.
- 2" wide.

Adjustable Box Turret End Supports				
Height	10" Deep	12" Deep	14" Deep	18" Deep
24"	BRE1010	BRE1012	BRE1014	BRE1018
34"	BRE2010	BRE2012	BRE2014	BRE2018

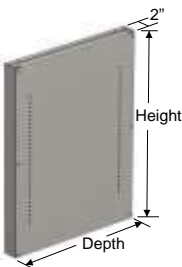

- Adjustable Box Turret Middle Supports are used to support reagent shelves. It may be used in conjunction with front rails to form a rigid reagent support structure.
- Adjustable slots are provided on both sides.
- 2" wide.

Adjustable Box Turret Middle Supports				
Height	10" Deep	12" Deep	14" Deep	18" Deep
24"	BRM1010	BRM1012	BRM1014	BRM1018
34"	BRM2010	BRM2012	BRM2014	BRM2018

*STEEL CASEWORK  
MISCELLANEOUS ITEMS - SUPPORT LEGS*



**Support Legs**



- Support Legs are used to support island countertops or aprons where base cabinets are not required.
- Available in sitting height (28-3/4"), ADA height (31-3/4") and standing height (34-3/4").
- 1-1/2" wide.
- Use option code "OL" when ordering Architectural Overlay design.

Depth	Sitting Hgt	Standing Hgt	ADA Hgt
28"	GLD2028	GLD1028	GLD3028
29"	GLD2029	GLD1029	GLD3029
34"	GLD2034	GLD1034	GLD3034
35"	GLD2035	GLD1035	GLD3035
46"	GLD2046	GLD1046	GLD3046
52"	GLD2052	GLD1052	GLD3052
58"	GLD2058	GLD1058	GLD3058

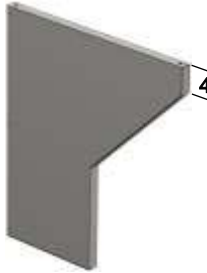

- Support Legs are used to support wall countertops or aprons where base cabinets are not required.
- Lower portion depth is half of overall depth.
- Support Legs come complete with wall mounting channel.
- Available in sitting height (28-3/4"), ADA height (31-3/4") and standing height (34-3/4").
- 1-1/2" wide.
- Use option code "OL" when ordering Architectural Overlay design.

Depth	Sitting Hgt	Standing Hgt	ADA Hgt
22"	GLA2022	GLA1022	GLA3022
23"	GLA2023	GLA1023	GLA3023
29"	GLA2029	GLA1029	GLA3029
35"	GLA2035	GLA1035	GLA3035

**Gable Legs**



- Gable Legs are used to support wall countertops or aprons where base cabinets are not required.
- Gable Legs come complete with wall mounting channel.
- Available in sitting height (28-3/4"), ADA height (31-3/4") and standing height (34-3/4").
- 1-1/2" wide.
- Use option code "OL" when ordering Architectural Overlay design.

Depth	Sitting Hgt	Standing Hgt	ADA Hgt
22"	GLS2022	GLS1022	GLS3022
23"	GLS2023	GLS1023	GLS3023
29"	GLS2029	GLS1029	GLS3029
35"	GLS2035	GLS1035	GLS3035

**Support Legs**

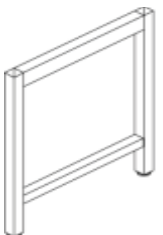

- Support Legs are used to support countertops where base cabinets are not required.
- Leveling bolts and PVC boots are included.
- Available in sitting height (28-3/4"), ADA height (31-3/4") and standing height (34-3/4").
- 2" X 2" tube.
- Suitable for use with TAC, TAA, TCC, TAB, TCB & TCE Tables.

Table Leg Assembly			
Depth	Sitting Hgt	Standing Hgt	ADA Hgt
22"	TLA2022	TLA1022	TLA5022
23"	TLA2023	TLA1023	TLA5023
28"	TLA2028	TLA1028	TLA5028
29"	TLA2029	TLA1029	TLA5029
35"	TLA2035	TLA1035	TLA5035

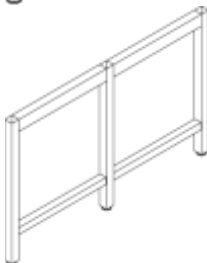

Double Table Leg Assembly			
Depth	Sitting Hgt	Standing Hgt	ADA Hgt
46"	TLA2046	TLA1046	TLA5046
52"	TLA2052	TLA1052	TLA5052
58"	TLA2058	TLA1058	TLA5058



*STEEL CASEWORK  
MISCELLANEOUS ITEMS - COMPONENTS*

**Table Legs**



Height	Item Number
28-3/4"	3200000
34-3/4"	3100000
31-3/4"	3500000

- Table Legs are used to support countertops where base cabinets are not required.
- Leveling bolts and PVC boots are included.
- Available in sitting height (28-3/4"), ADA height (31-3/4") and standing height (34-3/4").
- 2" x 2" tube.

**Service Legs**



Depth	Sitting Hgt	Standing Hgt	ADA Hgt
7"	SLG2007	SLG1007	SLG3007
11"	SLG2011	SLG1011	SLG3011
14"	SLG2014	SLG1014	SLG3014

- Service Legs are used to go behind cabinets when extra counter support is required.
- Service Legs can also be used by plumbers to attach piping within the service chase.
- Each assembly comes with 3/8" spring nuts & bolts.
- Available in sitting height (28-3/4"), ADA height (31-3/4") and standing height (34-3/4").

**Under Counter Support Brackets**

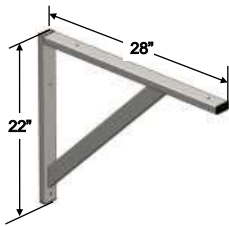

Item Number
CBS0001

- Under Counter Support Brackets are used to support counter tops.
- Suitable for 30" counter tops.
- Supports are 22" high by 28" deep welded from 1" x 2" 16 gauge steel tube.

**Stainless Steel Electrical Pedestal Boxes**

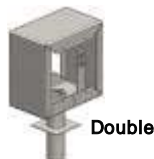
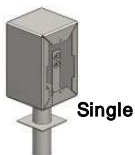

Single Gang	Double Gang
PBS	PBD

- Double-faced deck-mounted stainless steel outlet box only.
- Complete with threaded nipple to attach to mounting surface.
- Cover plate and receptacles are not included.
- Not CSA or UL approved.

*STEEL CASEWORK  
MISCELLANEOUS ITEMS - SERVICE DROPS*

**Full Access Island Service Drops**

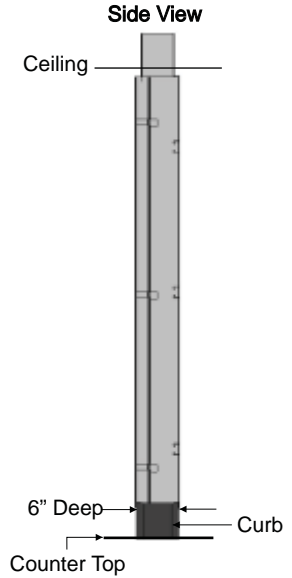
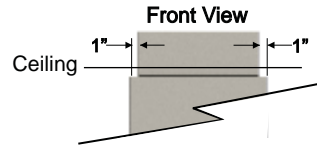
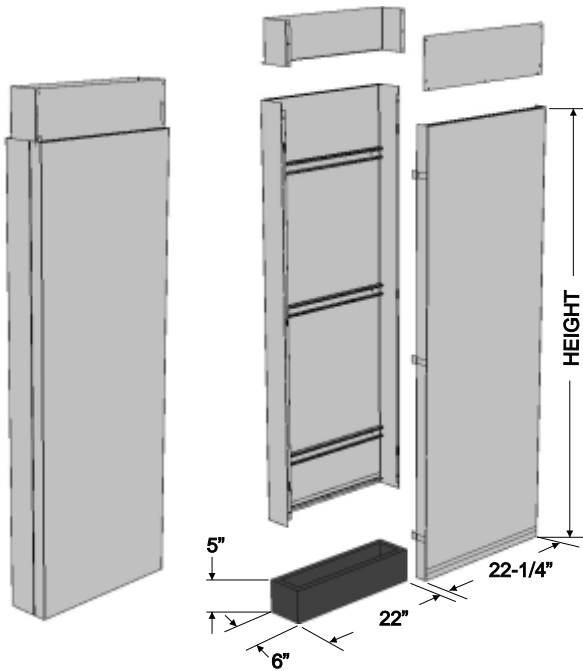

Height	Item Number
68"	SDP1368
73"	SDP1373
78"	SDP1378
90"	SDP1390

- ∞ Use to carry utilities from the counter top up through the ceiling.
- ∞ Service Drop offers full height (from counter top to ceiling) access to services.
- ∞ Front panel attaches with 'Z' clip.
- ∞ Designed to fit on a 22" wide x 5" high x 6" deep curb.

**Full Access Wall Service Drops**

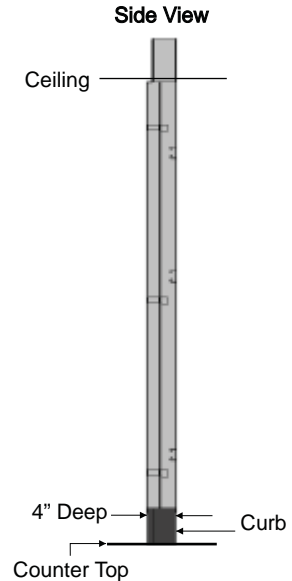
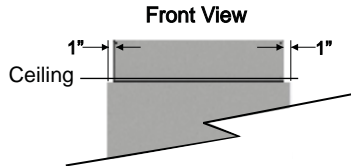
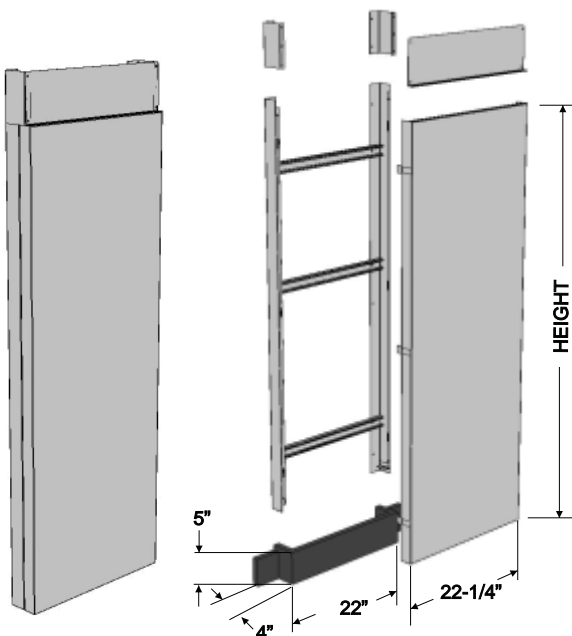

Height	Item Number
68"	SDP1468
73"	SDP1473
78"	SDP1478
90"	SDP1490

- ∞ Use to carry utilities from the counter top up through the ceiling.
- ∞ Service Drop offers full height (from counter top to ceiling) access to services.
- ∞ Front panel attaches with 'Z' clip.
- ∞ Designed to fit on a 22" wide x 5" high x 4" deep curb.



*STEEL CASEWORK  
MISCELLANEOUS ITEMS - SERVICE DROPS*

**Service Drops**

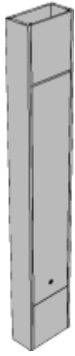

Top View



Height	6" Deep		8" Deep	
	12" Wide	24" Wide	12" Wide	24" Wide
78"	SDP3078	SDP4078	SDP1078	SDP2078
90"	SDP3090	SDP4090	SDP1090	SDP2090

- ∞ Use to carry utilities from the counter top up through the ceiling - for wall and island applications.
- ∞ Each assembly consists of two 12" high fixed upper and lower panels and a lift off center panel.
- ∞ 78" high service drop has 54" center lift off panel.
- ∞ 90" high service drop has 66" center lift off panel.

**Radius Island Service Drops**

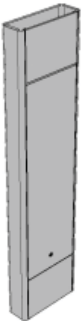

Top View



Height	12" Wide	24" Wide
78"	SDP1178	SDP2178
90"	SDP1190	SDP2190

- ∞ Use to carry utilities from the counter top up through the ceiling - for island applications.
- ∞ Each assembly consists of two 12" high fixed upper and lower panels and a lift off center panel.
- ∞ 78" high service drop has 54" center lift off panel.
- ∞ 90" high service drop has 66" center lift off panel.
- ∞ 6" deep (maximum depth available).

**Radius Wall Service Drops**



Top View



Height	12" Wide	24" Wide
78"	SDP1278	SDP2278
90"	SDP1290	SDP2290

- ∞ Use to carry utilities from the counter top up through the ceiling - for wall applications.
- ∞ Each assembly consists of two 12" high fixed upper and lower panels and a lift off center panel.
- ∞ 78" high service drop has 54" center lift off panel.
- ∞ 90" high service drop has 66" center lift off panel.
- ∞ 6" deep (maximum depth available).

**Service Drop Ceiling Trims**



Depth	12" Wide	24" Wide
6"	EDC1006	EDC2006
8"	EDC1000	EDC2000

- ∞ Not for use with Radius and Full access Service Drops.
- ∞ Required when Service Drop extends past the ceiling tile.
- ∞ Suitable for a 6" and 8" deep Service Drop.

*STEEL CASEWORK  
MISCELLANEOUS ITEMS - CYLINDER STORAGE RACKS*

**Cylinder Storage Racks**



2 Cylinder rack shown

Width	Item Number	Capable of Holding
16"	CSR1116	1 Cylinder
30"	CSR1230	2 Cylinders
44"	CSR1344	3 Cylinders
58"	CSR1458	4 Cylinders
72"	CSR1572	5 Cylinders

- Holds up to 10" diameter cylinders.
- Welded steel rack 30"H x 16"D
- Secure to both walls and floor with ½" steel anchor bolts.
- Non-kink zinc plated chain.

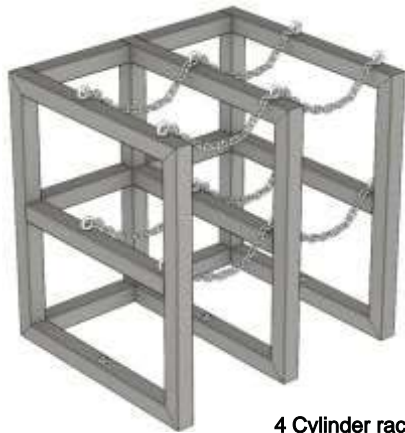

4 Cylinder rack shown

Width	Item Number	Capable of Holding
16"	CSR2116	2 Cylinders
30"	CSR2230	4 Cylinders
44"	CSR2344	6 Cylinders
58"	CSR2458	8 Cylinders
72"	CSR2572	10 Cylinders

- Holds up to 10" diameter cylinders.
- Welded steel rack 30"H x 26"D
- Secure to both walls and floor with ½" steel anchor bolts.
- Non-kink zinc plated chain.



6 Cylinder rack shown

Width	Item Number	Capable of Holding
16"	CSR3116	3 Cylinders
30"	CSR3230	6 Cylinders
44"	CSR3344	9 Cylinders
58"	CSR3458	12 Cylinders
72"	CSR3572	15 Cylinders

- Holds up to 10" diameter cylinders.
- Welded steel rack 30"H x 38"D
- Secure to both walls and floor with ½" steel anchor bolts.
- Non-kink zinc plated chain.

*STEEL CASEWORK*  
*MISCELLANEOUS ITEMS - REAGENT ISLAND SHELVING UNIT*

**Reagent Island Shelving Unit**

Reagent Island Shelving Units are designed to provide support for shelving and are 1" wide by 2" deep. Units are available in custom lengths to suit your exact requirements.



**Reagent Uprights**



**Item Number**  
RIV0090

- Used to create island assemblies where upright shelving is needed and relies on adjacent fixed casework for support.
- Reagent Uprights are 90" high by 1" wide by 2" deep tubing and are supplied with base support and hardware.
- Uprights are double slotted on both sides allowing shelving to be adjustable in 1" increments.
- Reagent Uprights are only suitable with "RIB" Shelf Brackets.
- Reagent Uprights are not suitable for suspending cabinets or work surfaces.

**Reagent Upper Rail**



**Item Number**  
RIH0120

- Used for island assemblies where upright shelving is needed and relies on adjacent fixed casework for support.
- Reagent Upper Rails are 1" high by 2" deep by 120" long tubing.
- Maximum length available without a seam in upper rail is 120" long.
- Available in custom lengths to suit your requirements.
- Supplied with two black plastic end caps.

**Reagent Upper Rail Joints**

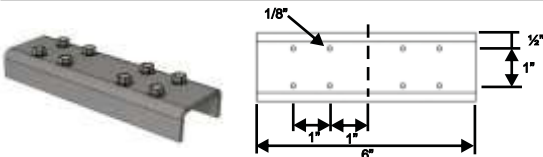

**Item Number**  
RIJ0000

- Used for joining two Reagent Upper Rails together.
- Fits inside of 1" high by 2" deep tubing.
- Reagent Upper Rail Joints is 6" long.
- Supplied with hardware.

*STEEL CASEWORK  
MISCELLANEOUS ITEMS - REAGENT ISLAND SHELVING UNIT*

**Reagent Steel and Wood Shelves**



- ∞ Shelves are actual widths.
- ∞ Add 1" angles to shelves by using option codes:
  - AR (Rear Shelf Angle welded to shelf)
  - AF (Front Shelf Angle welded to shelf)
  - AB (Rear and Front Shelf Angle welded to shelf)



- ∞ Shelves are actual widths.
- ∞ For wood shelving options see page N8.

Steel Shelves					
Width	10" Deep	12" Deep	14" Deep	16" Deep	18" Deep
24"	RIS1024	RIS1224	RIS1424	RIS1624	RIS1824
30"	RIS1030	RIS1230	RIS1430	RIS1630	RIS1830
36"	RIS1036	RIS1236	RIS1436	RIS1636	RIS1836
42"	RIS1042	RIS1242	RIS1442	RIS1642	RIS1842
48"	RIS1048	RIS1248	RIS1448	RIS1648	RIS1848
60"	RIS1060	RIS1260	RIS1460	RIS1660	RIS1860
513mm	RIS100A	RIS120A	RIS140A	RIS160A	RIS180A
1000mm	RIS100B	RIS120B	RIS140B	RIS160B	RIS180B
1512mm	RIS100C	RIS120C	RIS140C	RIS160C	RIS180C
2000mm	RIS100D	RIS120D	RIS140D	RIS160D	RIS180D

Wood Shelves					
Width	10" Deep	12" Deep	14" Deep	16" Deep	18" Deep
24"	RIS1024W	RIS1224W	RIS1424W	RIS1624W	RIS1824W
30"	RIS1030W	RIS1230W	RIS1430W	RIS1630W	RIS1830W
36"	RIS1036W	RIS1236W	RIS1436W	RIS1636W	RIS1836W
42"	RIS1042W	RIS1242W	RIS1442W	RIS1642W	RIS1842W
48"	RIS1048W	RIS1248W	RIS1448W	RIS1648W	RIS1848W
60"	RIS1060W	RIS1260W	RIS1460W	RIS1660W	RIS1860W
513mm	RIS100AW	RIS120AW	RIS140AW	RIS160AW	RIS180AW
1000mm	RIS100BW	RIS120BW	RIS140BW	RIS160BW	RIS180BW
1512mm	RIS100CW	RIS120CW	RIS140CW	RIS160CW	RIS180CW
2000mm	RIS100DW	RIS120DW	RIS140DW	RIS160DW	RIS180DW

**Reagent Shelf Angles**



- ∞ Shelf angles can be added to steel shelves and are used to stop items from sliding off shelving.
- ∞ 2" high with a 1" return and notched for shelf brackets.
- ∞ Only suitable for RIS shelves.

Width	Item Number
20"	RSA2120
24"	RSA2124
30"	RSA2130
36"	RSA2136
42"	RSA2142
48"	RSA2148
60"	RSA2160
72"	RSA2172

**Reagent Shelf Brackets**

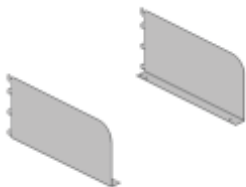

Depth	Item Number
10"	RIB0010
12"	RIB0012
14"	RIB0014
16"	RIB0016
18"	RIB0018

- ∞ Brackets only suitable for Reagent components.
- ∞ Pair of shelf brackets are 6" high.

**Reagent Inverted Shelf Brackets**

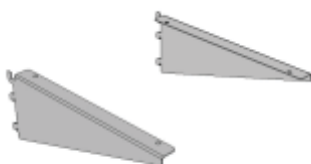

Depth	Item Number
10"	RIB1010
12"	RIB1012
14"	RIB1014
16"	RIB1016
18"	RIB1018

- ∞ Brackets only suitable for Reagent components.
- ∞ Pair of shelf brackets are 4-1/4" high.

*STEEL CASEWORK*  
*MISCELLANEOUS ITEMS - SIGMA FLEX™ WALL PILASTERS & SHELVES*

**Sigma Flex™ Wall Pilasters**



- Single Slotted Pilasters are 13/16" deep by 1-1/4" wide.
- Double Slotted Pilasters are 13/16" deep by 2-1/2" wide.
- Pilasters are adjustable in 1" increments.
- Fastens to wall to give support structure where no services are required.
- Ensure wall is of sufficient strength to support intended load (significant blocking required).
- Accepts Sigma Flex™ shelves.

Height	Single Slotted	Double Slotted
18"	FPA1018	FPA0018
24"	FPA1024	FPA0024
30"	FPA1030	FPA0030
36"	FPA1036	FPA0036
42"	FPA1042	FPA0042
48"	FPA1048	FPA0048
60"	FPA1060	FPA0060
72"	FPA1072	FPA0072
96"	FPA1096	FPA0096

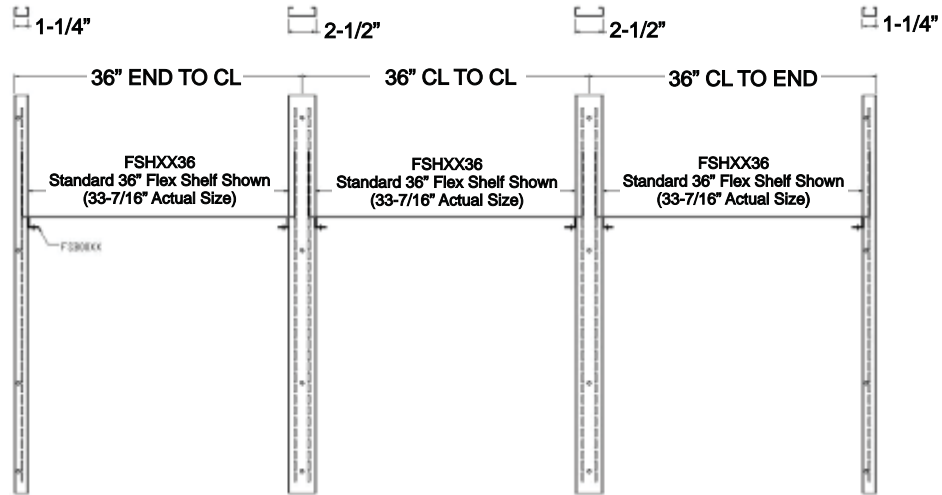

**Sigma Flex™ Steel and Wood Shelves**



Steel Shelves							
Width	6" Deep	8" Deep	10" Deep	12" Deep	14" Deep	18" Deep	24" Deep
24"	FSH0624	FSH0824	FSH1024	FSH1224	FSH1424	FSH1824	FSH2424
30"	FSH0630	FSH0830	FSH1030	FSH1230	FSH1430	FSH1830	FSH2430
36"	FSH0636	FSH0836	FSH1036	FSH1236	FSH1436	FSH1836	FSH2436
42"	FSH0642	FSH0842	FSH1042	FSH1242	FSH1442	FSH1842	FSH2442
48"	FSH0648	FSH0848	FSH1048	FSH1248	FSH1448	FSH1848	FSH2448
54"	FSH0654	FSH0854	FSH1054	FSH1254	FSH1454	FSH1854	FSH2454
60"	FSH0660	FSH0860	FSH1060	FSH1260	FSH1460	FSH1860	FSH2460
66"	FSH0666	FSH0866	FSH1066	FSH1266	FSH1466	FSH1866	FSH2466
72"	FSH0672	FSH0872	FSH1072	FSH1272	FSH1472	FSH1872	FSH2472

- Shelf suitable for any Sigma Flex™ support structure or Sigma Cart™.
- Attach to shelf brackets with screws (screws not included).
- Nominal width.



Wood Shelves							
Width	6" Deep	8" Deep	10" Deep	12" Deep	14" Deep	18" Deep	24" Deep
24"	FSH0624W	FSH0824W	FSH1024W	FSH1224W	FSH1424W	FSH1824W	FSH2424W
30"	FSH0630W	FSH0830W	FSH1030W	FSH1230W	FSH1430W	FSH1830W	FSH2430W
36"	FSH0636W	FSH0836W	FSH1036W	FSH1236W	FSH1436W	FSH1836W	FSH2436W
42"	FSH0642W	FSH0842W	FSH1042W	FSH1242W	FSH1442W	FSH1842W	FSH2442W
48"	FSH0648W	FSH0848W	FSH1048W	FSH1248W	FSH1448W	FSH1848W	FSH2448W
54"	FSH0654W	FSH0854W	FSH1054W	FSH1254W	FSH1454W	FSH1854W	FSH2454W
60"	FSH0660W	FSH0860W	FSH1060W	FSH1260W	FSH1460W	FSH1860W	FSH2460W

- Shelf suitable for any Sigma Flex™ support structure or Sigma Cart™.
- Attach to shelf brackets with screws (screws not included).
- Nominal width.
- For wood shelving options see page N8.

*STEEL CASEWORK*

*MISCELLANEOUS ITEMS - SIGMA FLEX™ WALL PILASTER BRACKETS*

**Sigma Flex™ Top Shelf Brackets**



Depth	Item Number
6"	FIB0006
8"	FIB0008
10"	FIB0010
12"	FIB0012
14"	FIB0014
18"	FIB0018
24"	FIB0024

- Pair of steel top end brackets designed to fit Adjustable Outer Shelf and can be used for shelves of different materials.
- Adjustable in 1" increments.
- Brackets only compatible with Sigma Flex™ structures or Sigma Cart™.

**Sigma Flex™ Lower Shelf Brackets**



Depth	Item Number
6"	FSB0006
8"	FSB0008
10"	FSB0010
12"	FSB0012
14"	FSB0014
18"	FSB0018
24"	FSB0024

- Pair of steel end brackets designed to fit Adjustable Outer Shelf and can be used for shelves of different materials.
- Adjustable in 1" increments.
- Brackets only compatible with Sigma Flex™ structures or Sigma Cart™.

**Sigma Flex™ Radius Top Shelf Brackets**

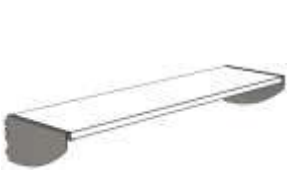

Depth	Item Number
6"	FIB3006
8"	FIB3008
10"	FIB3010
12"	FIB3012
14"	FIB3014
18"	FIB3018
24"	FIB3024

- Pair of steel top end brackets designed to fit Adjustable Outer Shelf and can be used for shelves of different materials.
- Adjustable in 1" increments.
- Brackets only compatible with Sigma Flex™ structures or Sigma Cart™.

**Sigma Flex™ Radius Outer Shelf Brackets**

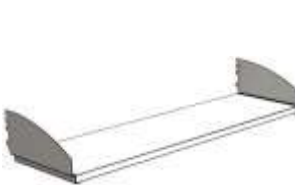

Depth	Item Number
6"	FSB3006
8"	FSB3008
10"	FSB3010
12"	FSB3012
14"	FSB3014
18"	FSB3018
24"	FSB3024

- Pair of steel end brackets designed to fit Adjustable Outer Shelf and can be used for shelves of different materials.
- Adjustable in 1" increments.
- Brackets only compatible with Sigma Flex™ structures or Sigma Cart™.

**Sigma Flex™ Tapered Top Shelf Brackets**



Depth	Item Number
6"	FIB4006
8"	FIB4008
10"	FIB4010
12"	FIB4012
14"	FIB4014
18"	FIB4018
24"	FIB4024

- Pair of steel top end brackets designed to fit Adjustable Outer Shelf and can be used for shelves of different materials.
- Adjustable in 1" increments.
- Brackets only compatible with Sigma Flex™ structures or Sigma Cart™.

**Sigma Flex™ Tapered Outer Shelf Brackets**

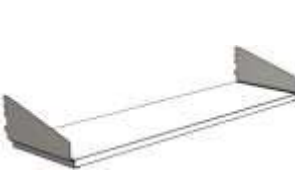

Depth	Item Number
6"	FSB4006
8"	FSB4008
10"	FSB4010
12"	FSB4012
14"	FSB4014
18"	FSB4018
24"	FSB4024

- Pair of steel end brackets designed to fit Adjustable Outer Shelf and can be used for shelves of different materials.
- Adjustable in 1" increments.
- Brackets only compatible with Sigma Flex™ structures or Sigma Cart™.



*STEEL CASEWORK*

*MISCELLANEOUS ITEMS - SIGMA FRAME™ WALL PILASTERS BRACKETS & SHELVES*

**Sigma Frame™ Wall Pilaster**

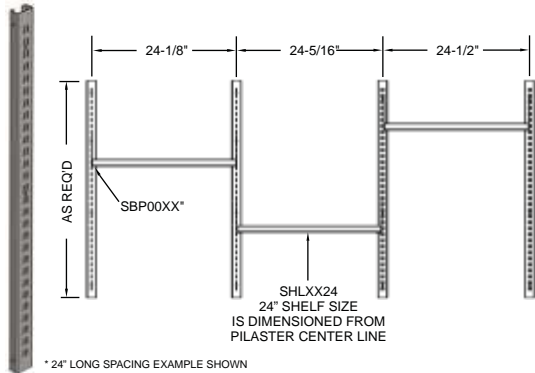

Height	Single Slotted	Double Slotted
18"	WPA1018	WPA0018
24"	WPA1024	WPA0024
30"	WPA1030	WPA0030
36"	WPA1036	WPA0036
42"	WPA1042	WPA0042
48"	WPA1048	WPA0048
60"	WPA1060	WPA0060
72"	WPA1072	WPA0072
84"	WPA1084	WPA0084
96"	WPA1096	WPA0096

- Pilasters only suitable for Sigma Frame™, Inverted Shelf Brackets, "SBP" and "WPA" components.
- Wall Pilasters should be mounted 1/2" on center wider than the shelf length.
- 1-5/8" wide by 13/16" deep.

**Sigma Frame™ Steel and Wood Shelves For Wall Pilasters**



- ∞ Shelves are actual widths.
- ∞ Add 1" angles to shelves by using option codes:
  - AR (Rear Shelf Angle welded to shelf)
  - AF (Front Shelf Angle welded to shelf)
  - AB (Rear and Front Shelf Angle welded to shelf)

Steel Shelves					
Width	10" Deep	12" Deep	14" Deep	16" Deep	18" Deep
24"	SHL1024	SHL1224	SHL1424	SHL1624	SHL1824
30"	SHL1030	SHL1230	SHL1430	SHL1630	SHL1830
36"	SHL1036	SHL1236	SHL1436	SHL1636	SHL1836
42"	SHL1042	SHL1242	SHL1442	SHL1642	SHL1842
48"	SHL1048	SHL1248	SHL1448	SHL1648	SHL1848
60"	SHL1060	SHL1260	SHL1460	SHL1660	SHL1860
513mm	SHL100A	SHL120A	SHL140A	SHL160A	SHL180A
1000mm	SHL100B	SHL120B	SHL140B	SHL160B	SHL180B
1512mm	SHL100C	SHL120C	SHL140C	SHL160C	SHL180C
2000mm	SHL100D	SHL120D	SHL140D	SHL160D	SHL180D



- Shelves are actual widths.
- Shelves are 1" thick.
- For wood shelving options see page N8.

Wood Shelves					
Width	10" Deep	12" Deep	14" Deep	16" Deep	18" Deep
24"	SHL1024W	SHL1224W	SHL1424W	SHL1624W	SHL1824W
30"	SHL1030W	SHL1230W	SHL1430W	SHL1630W	SHL1830W
36"	SHL1036W	SHL1236W	SHL1436W	SHL1636W	SHL1836W
42"	SHL1042W	SHL1242W	SHL1442W	SHL1642W	SHL1842W
48"	SHL1048W	SHL1248W	SHL1448W	SHL1648W	SHL1848W
60"	SHL1060W	SHL1260W	SHL1460W	SHL1660W	SHL1860W
513mm	SHL100AW	SHL120AW	SHL140AW	SHL160AW	SHL180AW
1000mm	SHL100BW	SHL120BW	SHL140BW	SHL160BW	SHL180BW
1512mm	SHL100CW	SHL120CW	SHL140CW	SHL160CW	SHL180CW

**Sigma Frame™ Shelf Brackets For Wall Pilasters**

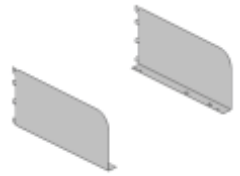

- ∞ Brackets only suitable for Sigma Frame™ and "WPA" components.
- ∞ Pair of shelf brackets are 6" high.
- ∞ Add option code NN for no alignment tabs on SBP brackets.

Depth	Item Number
10"	SBP0010
12"	SBP0012
14"	SBP0014
16"	SBP0016
18"	SBP0018

**Sigma Frame™ Inverted Shelf Brackets For Wall Pilasters**

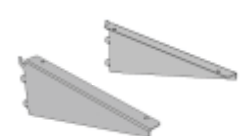

- ∞ Brackets only suitable for Reagent components.
- ∞ Pair of shelf brackets are 4-1/4" high.

Depth	Item Number
10"	SBP1010
12"	SBP1012
14"	SBP1014
16"	SBP1016
18"	SBP1018

*STEEL CASEWORK  
MISCELLANEOUS ITEMS*

**Under Mount Shelf Task Lights**



Length of Light	Item Number
14"	TLW0014
23"	TLW0023
36"	TLW0036
48"	TLW0048
59"	TLW0059

- **Order light a minimum 6" shorter than the shelf.**
- Low profile (.98" wide by 1.65" high) T5 fluorescent task light mounts to underside of the shelf.
- Shatterproof polycarbonate lens protects the lamp.
- Easily linkable in one continuous line using Flexible Connectors. 6" Flexible Connector comes standard with each light. See below to order longer Flexible Connectors.
- On-off rocker switch located on the side of the fixture.
- 8000 hour, cool white replaceable T5 lamp included.
- UL listed.
- Ships loose, includes Mott's mounting brackets.

**Task Light Flexible Connectors**



Width	Item Number
12"	LFC0012
24"	LFC0024
36"	LFC0036

- Flexible Connector allows to easily link T5 fluorescent lights in one continuous line.
- Ships loose.



*METAL FRAMING SYSTEM*

**Continuous Slot Metal Framing System**



**For additional information and help in planning contact Mott Manufacturing.**

*METAL FRAMING SYSTEM*

**Connection Instructions**

- Installs quickly
- Completely adjustable
- Re-usable
- Eliminates all welding, drilling and use of special tools



1. Place the spring nut anywhere along the continuous slotted channel.



2. Turn clockwise 90° to line up the grooves in the nut with the inturned edges of the channel.

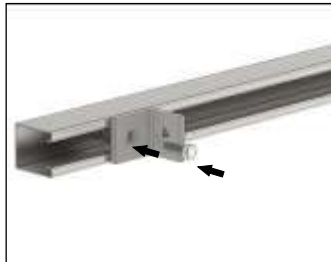

3. Inset the bolt through the fitting and into the spring nut.

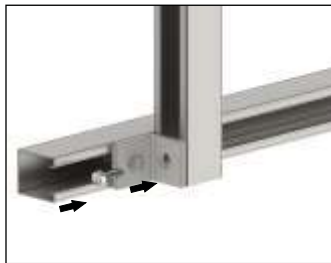

4. Added channels are able to be bolted to the existing fitting by following procedure described in steps 1-3.

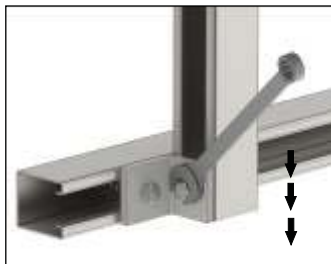

5. Using a wrench to tighten the bolt will lock the serrated teeth of the channel nut onto the inturned edges of the channel.

*METAL FRAMING SYSTEM  
DETAILS AND SPECIFICATIONS*

**1-5/8" x 1-5/8" Channel**

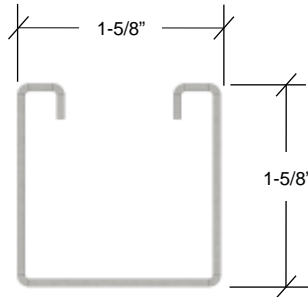

Unistrut channels are accurately and carefully cold rolled formed to size from low-carbon strip steel. Cold rolled and stainless steel are offered in both 12 gauge and 14 gauge.

**1-5/8" x 13/16" Channel**

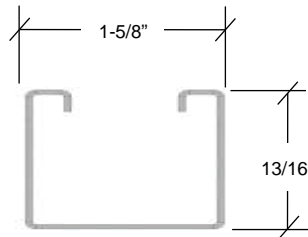

Unistrut channels are accurately and carefully cold rolled formed to size from low-carbon strip steel. Cold rolled and stainless steel are offered only 16 gauge.

**Channel Details**

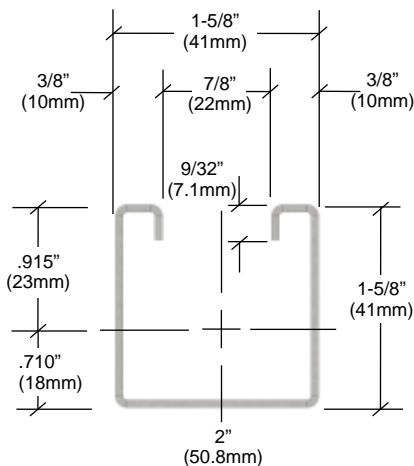

- Wt/100 Ft: 378 Lbs (281 kg/100m)
- Allowable Moment 5,070 In-Lbs (570 N\*m)
- 12 gauge Nominal Thickness .105" (2.7mm)

*METAL FRAMING SYSTEM  
CHANNELS*

**Channels 1-5/8" x 1-5/8"**

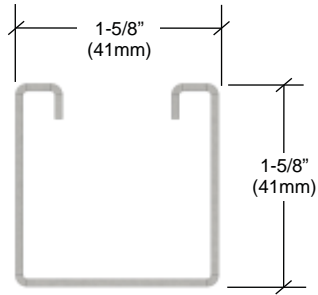

Length	12 Gauge	14 Gauge
24"	SMF1224	SMF1424
48"	SMF1248	SMF1448
72"	SMF1272	SMF1472
96"	SMF1296	SMF1496
120"	SMF1220	SMF1420

- Width : 1-5/8"
- Height: 1-5/8"
- Available in powder coated steel or stainless steel



**Channels 1-5/8" x 13/16"**

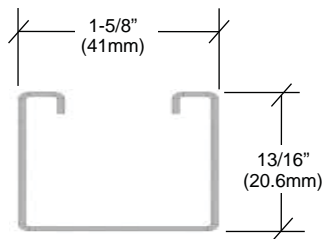

Length	16 Gauge
24"	SMF1624
48"	SMF1648
72"	SMF1672
96"	SMF1696
120"	SMF1620

- Width : 1-5/8"
- Height: 13/16"
- Available in powder coated steel or stainless steel



*METAL FRAMING SYSTEM  
MISCELLANEOUS HARDWARE*

**Channel Nuts**

Channel nuts are machined from steel bars and are case hardened. Nuts are designed with shaped ends that allow them to be turned clockwise within the channel after insertion through the opening. The channel nut is held in place when the two grooves with the serrated teeth engage the inturns of the channel after the bolt is tightened. This stops any movement of the nut and bolt within the framing member. Channel nuts conform to ASTM Specification A1011 SS GR 33 (material only). Screws conform to SAE J429 GR.

**Short Spring**

SMFN100

- Thread: 3/8"-16
- Thickness: 1/4"
- For use with 1-5/8" X 13/16" Channel
- Box of 100 pcs.

**Regular Spring**

SMFN200

- Thread: 3/8"-16
- Thickness: 1/4"
- For use with 1-5/8" X 1-5/8" Channel
- Box of 100 pcs.

**Miscellaneous Hardware**

**Hex Head Bolt 1"**

SMFB100

**Hex Head Bolt 1-1/4"**

SMFB200

- Thread 3/8"-16
- Box of 100 pcs.

**Lock Washer**

SMFLW00

- Size: 3/8"
- Box of 100 pcs.

**Flat Washer**

SMFFW00

- Size: 3/8"
- Box of 100 pcs.

**Hex Nut**

SMFHN00

- Size: 3/8"
- Box of 100 pcs.



**Threaded Rod**

SMFTR00

- Thread: 3/8"-16
- Length: 6'
- Electro-galvanized

*METAL FRAMING SYSTEM  
MISCELLANEOUS COMPONENTS*

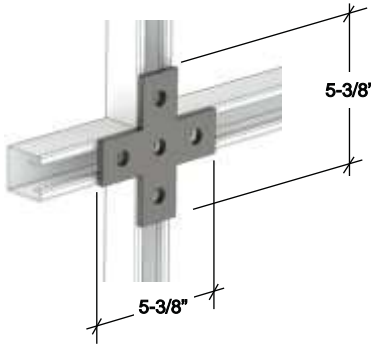
**Flat Plate Fittings**



**Item Number**  
SMFFP00

- Thickness: 1/4"
- Hole Diameter: 9/16" DIA.



**Item Number**  
SMFFP03

- Thickness: 1/4"
- Hole Diameter: 9/16" DIA.

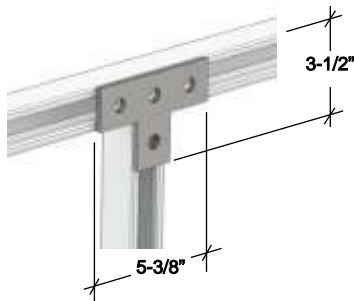

**Item Number**  
SMFFP01

- Thickness: 1/4"
- Hole Diameter: 9/16" DIA.



**Item Number**  
SMFFP04

- Thickness: 1/4"
- Hole Diameter: 9/16" DIA.

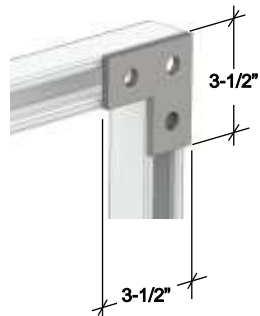

**Item Number**  
SMFFP02

- Thickness: 1/4"
- Hole Diameter: 9/16" DIA.

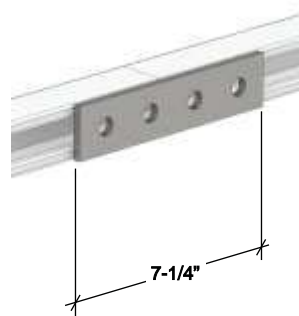

**Item Number**  
SMFFP05

- Thickness: 1/4"
- Hole Diameter: 9/16" DIA.

METAL FRAMING SYSTEM  
MISCELLANEOUS COMPONENTS

**90° Angle Fittings**

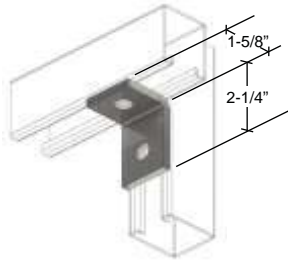

**Two Hole Corner 1-5/8" x 2-1/4"**  
SMFAF00

- Thickness: 1/4"
- Width: 1-5/8"
- Hole Diameter: 9/16"
- Hole Spacing: 1-7/8"
- Edge Distance: 13/16"

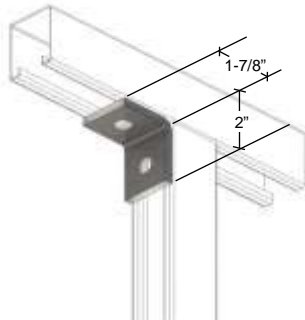

**Two Hole Corner 1-7/8" x 2"**  
SMFAF10

- Thickness: 1/4"
- Width: 1-5/8"
- Hole Diameter: 9/16"
- Hole Spacing: 1-7/8"
- Edge Distance: 13/16"

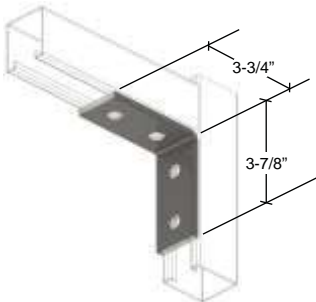

**Four Hole Corner 3-3/4" x 3-7/8"**  
SMFAF20

- Thickness: 1/4"
- Width: 1-5/8"
- Hole Diameter: 9/16"
- Hole Spacing: 1-7/8"
- Edge Distance: 13/16"

**Shelf Brackets**

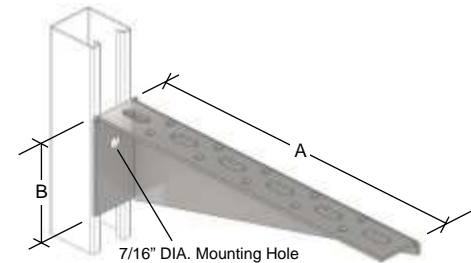
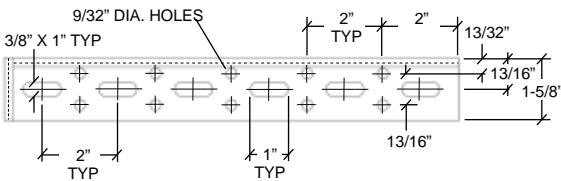

Right hand shown

Length	Height	Right Hand Bracket	Left Hand Bracket
A	B		
12"	3-7/16"	SMFRH12	SMFLH12
14"	3-15/16"	SMFRH14	SMFLH14
16"	4-7/16"	SMFRH16	SMFLH16
18"	4-15/16"	SMFRH18	SMFLH18
20"	5-7/16"	SMFRH20	SMFLH20
22"	5-15/16"	SMFRH22	SMFLH22

- Thickness: 12 gauge
- Number of Slots = A/2
- Number of Rows of Holes = (A/2) - 1

*METAL FRAMING SYSTEM  
MISCELLANEOUS COMPONENTS*

**Hat Channel Shelf Brackets For Wall Struts**

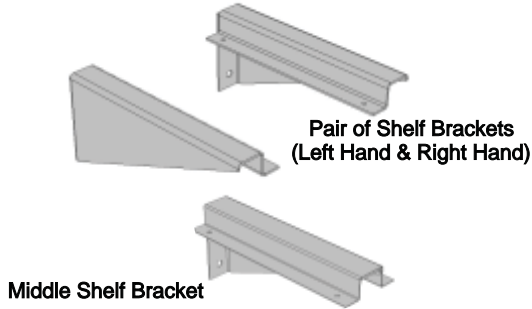

Depth	Pair Of Brackets	Middle Bracket
10"	TBP0010	TBD0010
12"	TBP0012	TBD0012
14"	TBP0014	TBD0014
16"	TBP0016	TBD0016
18"	TBP0018	TBD0018

- ∞ Steel shelf brackets suitable for Wall Struts.
- ∞ 5" high.

**Shelf Brackets For Wall Struts**

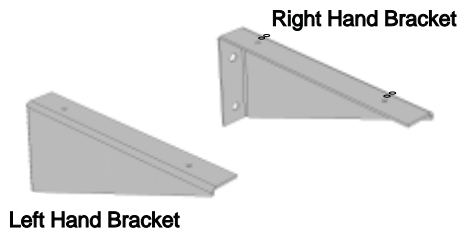

Depth	Left Hand Bracket	Right Hand Bracket
10"	TSL0010	TSR0010
12"	TSL0012	TSR0012
14"	TSL0014	TSR0014
16"	TSL0016	TSR0016
18"	TSL0018	TSR0018

- ∞ Steel shelf brackets suitable for Wall Struts.
- ∞ 5" high.



*METAL FRAMING SYSTEM  
MISCELLANEOUS COMPONENTS*

**Post Bases**

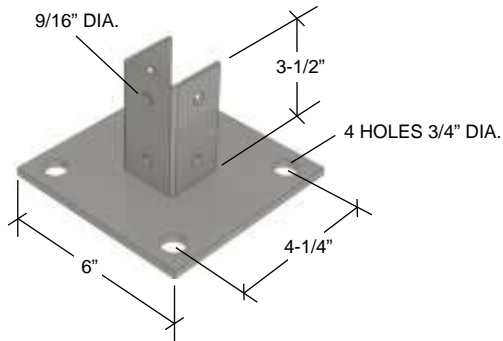

**Item Number**  
SMFPB10

- Thickness: 1/4"
- Hole Diameter: 3/4" DIA.

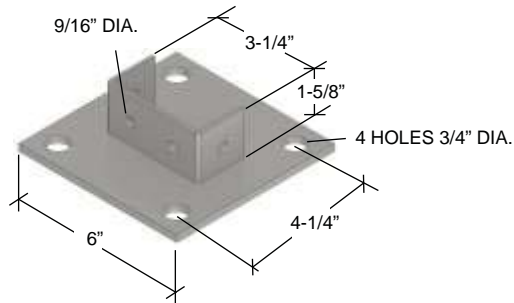

**Item Number**  
SMFPB20

- Thickness: 1/4"
- Hole Diameter: 3/4" DIA.

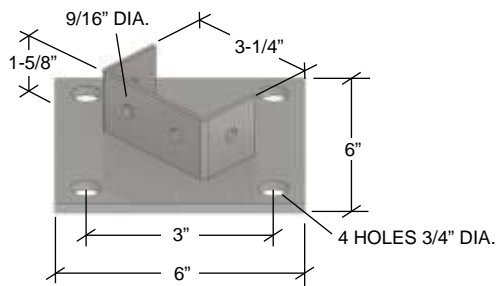

**Item Number**  
SMFPB30

- Thickness: 1/4"
- Hole Diameter: 3/4" DIA.

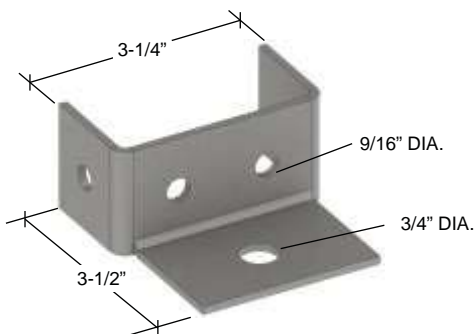

**Item Number**  
SMFPB40

- Thickness: 1/4"
- Hole Diameter: 9/16" DIA.

*WOOD CASEWORK  
INTRODUCTION - CASEWORK CONSTRUCTION DETAILS AND SPECIFICATIONS*

**Overview**

**Cabinets**

Mott casework can meet the most demanding specification, whether it is AWI Premium or an architect's 'signature' specification. We manufacture using premium grade techniques using material as outlined by the architect or lab planner in the specifications of each project. A variety of veneer panels and glues are available to meet just about any environmental, appearance, or durability requirement. Most of our cabinets are available in SEFA compliant versions; contact Mott for details.

Each base cabinet has a 1" thick top front rail and optional intermediate rail, 3/4" thick top and bottom back rails and are joined together with concealed hardwood dowels and NAUF glue. The front exposed edge is hardwood edgebanded in the same species as the face veneer. Wall and floor cabinets have 1" top panels and wall cabinets also have 1" bottom panels. Toe spaces are 3" deep by 4" high.

All base cabinets have a full height removable back panel. Drawer cabinets have an optional split back panel. Sink cabinets have a partial back panel to facilitate plumbing. Open and glazed cabinets have veneered back panels.

**Doors and Drawers**

Solid doors and drawers are 3/4" particle board. Glazed doors are framed and made from the same species as the face veneer. Drawer bodies are NAUF 1/2" 9-ply Baltic Birch dovetailed at all four corners. Powder coated cold rolled steel or stainless steel are other drawer body options available. Drawer bottoms are 1/4" hardboard or veneered panel that are let into routed slots on all four sides of the drawer body and hot glued along the entire perimeter on the bottom. Drawers Fronts and doors are edgebanded with hardwood of the same species as the face veneer.

**Hardware**

Doors that are 48" high and higher have at least three hinges and doors that are less than 48" high have two hinges. Standard hinges include five knuckle stainless steel hinge, three knuckle barrel hinge, and concealed European style hinge. Standard drawer suspension is 100 lbs full extension runners, optional 75lbs nylon tire or 200lbs full extension are available. File drawers are always 100lbs full extension. Glazed doors are 1/4" clear laminated safety glass, 3mm float glass or tempered glass held in place with a removable clear plastic retainer. Sliding doors shall be set in an extruded aluminum track.

**Shelves**

All shelves are made from veneer core panel product of the same species specified for the face veneer. Shelves are 1" thick and are adjustable on 1-1/4" increments and held in place via single pin supports or seismic plastic twin pin supports. The front is hardwood edgebanded in the same species as the face veneer.

**Table Frames and Apron Panels**

Frames are 3-3/4" high and 3/4" thick lumber. Legs are 2-1/8" X 2-1/8" solid lumber with 4" high flexible shoes. Frames are bracketed and securely bolted together (unless otherwise noted).

FSC certified sustainable materials and no added urea-formaldehyde (NAUF) are available options.

Mott Manufacturing wood casework division is working towards registering to the ISO 9001-2008 standard.

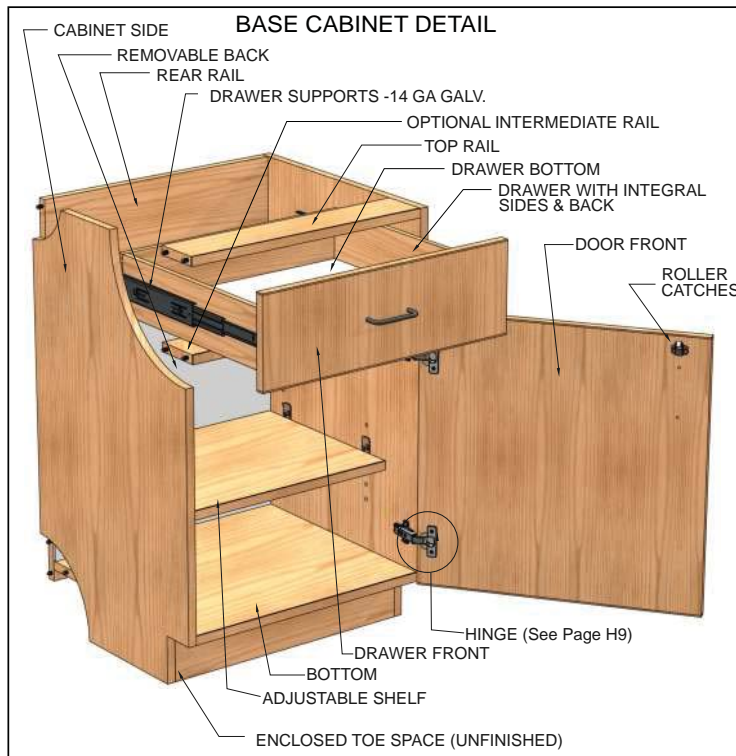

*WOOD CASEWORK  
INTRODUCTION - TYPICAL WORK AREAS*

**Details**

The following details are provided to illustrate how base cabinets, filler panels and countertops combine to construct a laboratory work area.

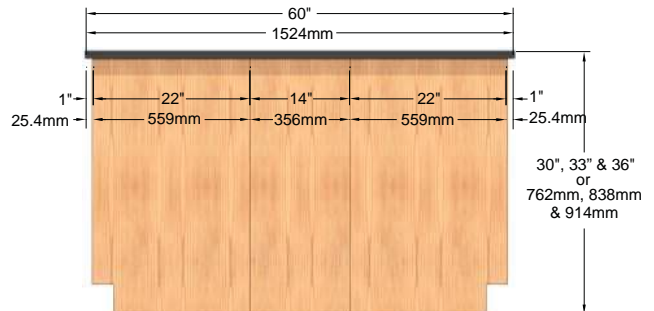
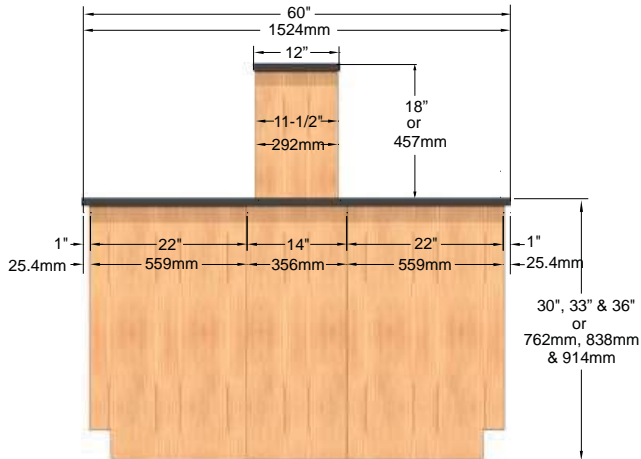

- Above is an island type configuration with 60" wide counter top, (2) 22" deep cabinets, a 14" removable filler panel and 12" reagent shelf.
- The area covered by the 14" removable filler panel provides a large accessible space for required services.
- Both base cabinet side panels can also be extended to 29" deep to eliminate the use of a 14" filler and provide a continuous cabinet look, cabinet interior will remain 20-1/8" deep.

- Above is an island type configuration with 60" wide counter top, (2) 22" deep cabinets, and a 14" removable filler panel.
- The area covered by the 14" removable filler panel provides a large accessible space for required services.
- Both base cabinet side panels can also be extended to 29" deep to eliminate the use of a 14" filler and provide a continuous cabinet look, cabinet interior will remain 20-1/8" deep.

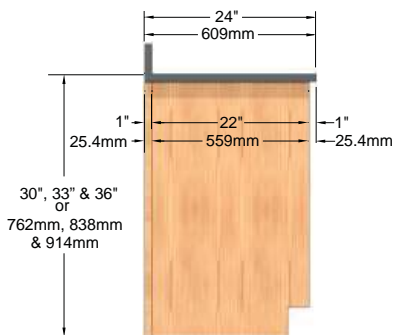

- Above is a standard base cabinet configuration with 24" deep counter top, 22" deep base cabinet and 1" filler panel.
- Base cabinet side panels can also be extended to 23" deep to eliminate the use of a 1" filler and provide a continuous cabinet look, cabinet interior will remain 20-1/8" deep.

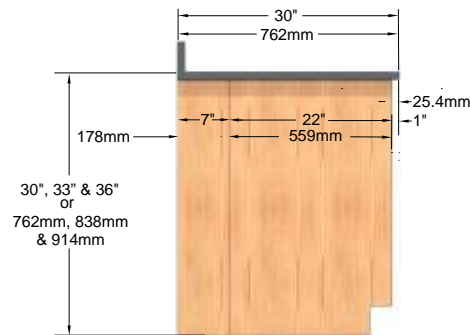

- Above is a base cabinet configuration with 30" deep counter top, 22" deep base cabinet and 7" removable filler panel.
- The area covered by the 7" removable filler panel provides accessible space for required services.
- Base cabinet side panels can also be extended to 29" deep to eliminate the use of a 7" filler and provide a continuous cabinet look, cabinet interior will remain 20-1/8" deep.

*WOOD CASEWORK  
INTRODUCTION - OPTIONAL METRIC SIZES*

**Base Cabinets**

Mott base cabinets are also available in metric widths of 513mm or 1000mm. The information below indicates the dimensions of metric base cabinets. To order metric base cabinets contact your nearest Mott dealer.

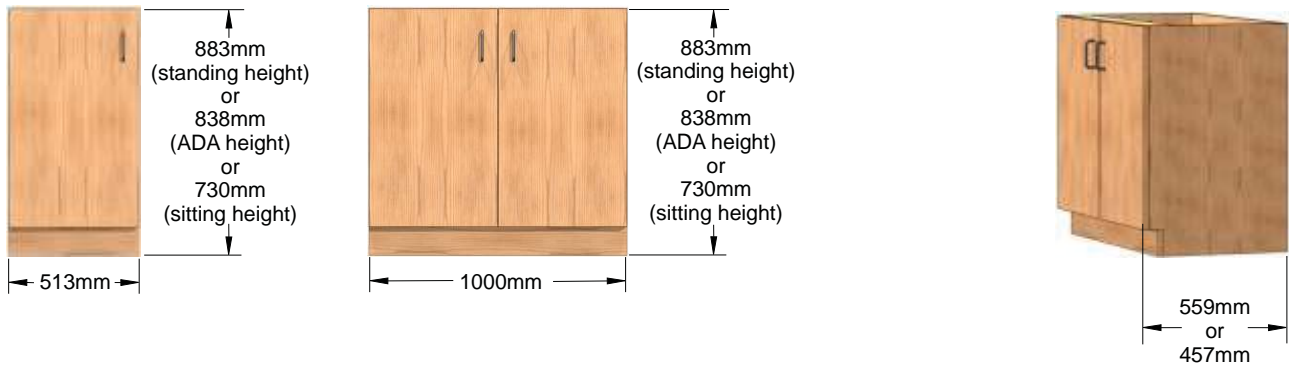

Note: 457mm available on selected specialty cabinets only.

**Wall Cabinets**

Mott wall cabinets are also available in metric widths of 513mm or 1000mm. The information below indicates the dimensions of metric wall cabinets. To order metric wall cabinets contact your nearest Mott dealer.

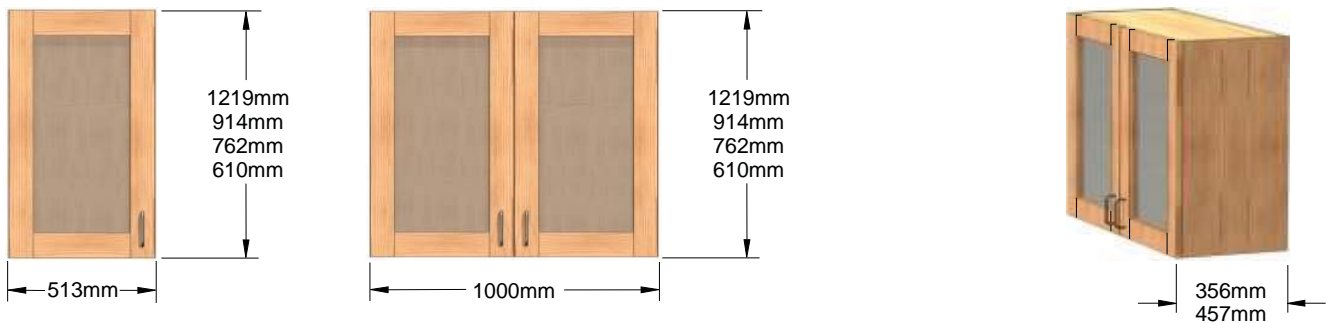

*WOOD CASEWORK  
INTRODUCTION - OPTIONAL METRIC SIZES*

**Floor Cabinets**

Mott floor cabinets are also available in metric widths of 513mm or 1000mm. The information below indicates the dimensions of metric floor cabinets. To order metric floor cabinets contact your nearest Mott dealer.

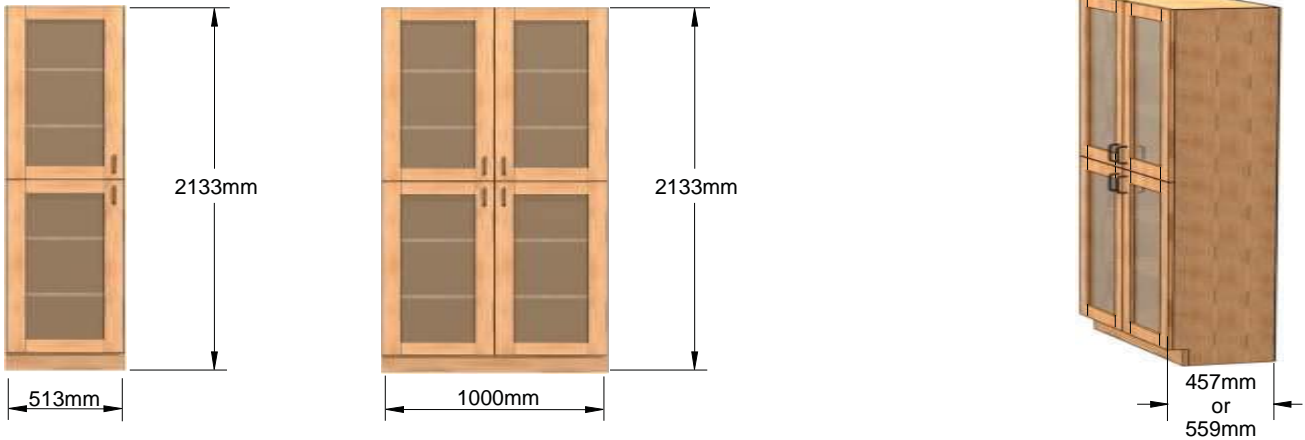

**Aprons and Tables**

Mott aprons and tables are also available in metric widths of 513mm, 1000mm and 1513mm. The information below indicates the dimensions of metric aprons and tables. To order metric aprons and tables contact your nearest Mott dealer.

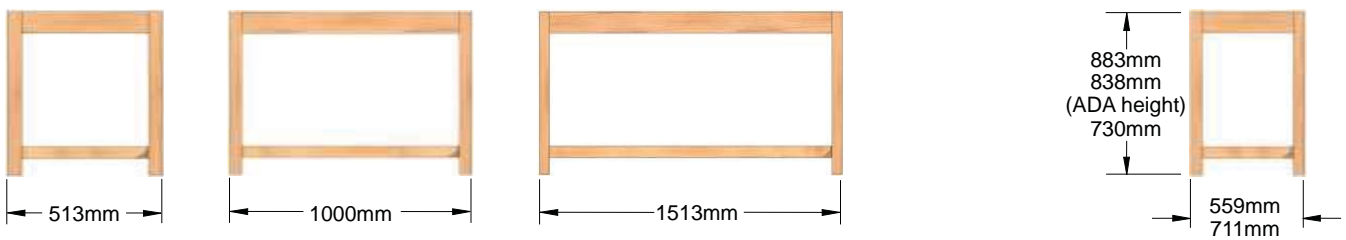

**Miscellaneous Items**

Mott miscellaneous items such as filler panels, service drops etc. are also available in metric widths. To order these items contact your nearest Mott dealer.

*WOOD CASEWORK  
PRODUCT SIZES AND DIMENSIONS*

**Base Cabinets**



Note: Lipped Overlay cabinets with door and drawer fronts are 3/8" less than standard depths.

**Wall Cabinets**

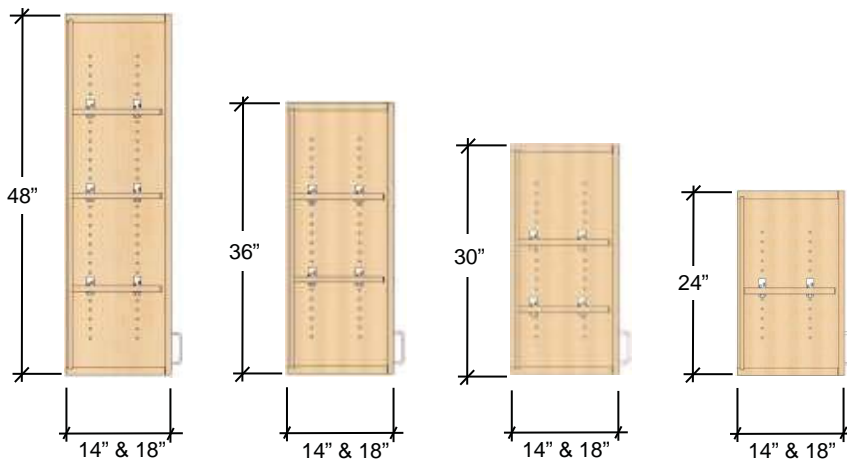

Note: Lipped Overlay cabinets with door and drawer fronts are 3/8" less than standard depths.

**Floor Cabinets**

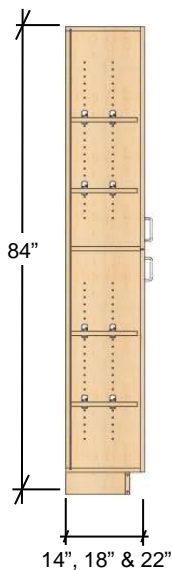

Note: Lipped Overlay cabinets with door and drawer fronts are 3/8" less than standard depths.

*WOOD CASEWORK  
OPTIONS*

**Standard Options**

**VENEER TYPE:**

- RED OAK - PLAIN SLICED
- RED OAK - RIFT CUT
- MAPLE - PLAIN SLICED
- MAPLE - QUARTER SLICED
- MAPLE - ROTARY SLICED
- BAMBOO - NATURAL
- BAMBOO - CARAMELIZED, EDGE CUT
- BAMBOO - EDGE CUT
- BEECH - QUARTER SLICED
- BEECH - EUROPEAN STEAMED
- BIRCH - ROTARY SLICED
- CHERRY - PLAIN SLICED
- RIBBON SAPELE - QUARTER SLICED
- WHITE SAPELE - QUARTER SLICED
- ANIGRE - QUARTERED W/ PLAIN FIGURE

**STAIN TYPE:**

- NATURAL
- CASHEW
- GINGER
- TOFFEE
- CIDER
- HAZELNUT

**GRAIN MATCH:**

- BOOK MATCHED
- SLIP MATCHED
- SEQUENCE MATCHED
- SAME FLITCH BOOK MATCHED
- SAME FLITCH RUNNING MATCHED
- OTHER (SPECIFY)

**FINISHES:**

- Meets SEFA 8 Standard
- OTHER

**CABINET CONSTRUCTION:**

- Meets SEFA 8
- OTHER

**OVERLAY STYLE:**

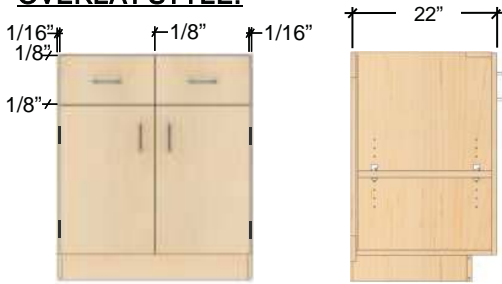

**FULL FLUSH OVERLAY Standard**  
*Flush Overlay cabinet fronts provide tight reveals by notching around the hinge*

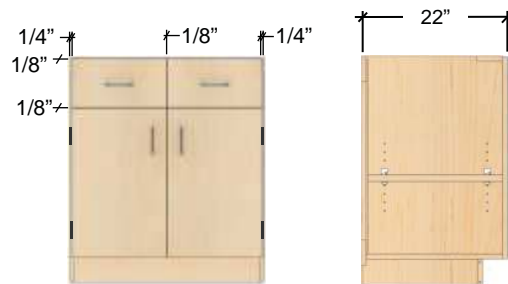

**REVEAL OVERLAY**  
*No notching on doors with balanced reveals*

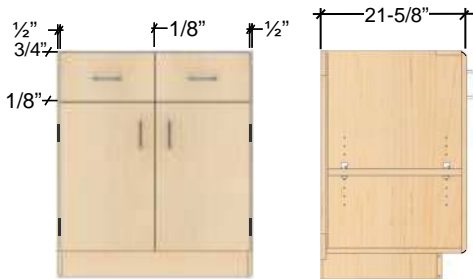

**LIPPED OVERLAY**  
*Lipped Overlay cabinet fronts have a combination grain direction*

**CABINET CORE:**

- VENEER CORE PLYWOOD Standard**  
*On the sides and bottom*
- PARTICLEBOARD CORE PLYWOOD**  
*On the sides and bottom*
- MDF CORE**  
*On the sides and bottom*
- COMBINATION CORE**

**DOOR AND DRAWER CORE:**

- PARTICLEBOARD CORE PLYWOOD Standard**
- MDF CORE**
- COMBINATION CORE**



*WOOD CASEWORK  
OPTIONS*

**Standard Options**

**CABINET TOP FRAME:**



**FRONT AND BACK RAILS Standard**  
*Front horizontal and rear vertical rail*



**FULL TOP FRAME**  
*Front, rear and side vertical rails*

**EDGE BANDING:**

**ROLL TYPE EDGE BAND Standard**  
*100% hardwood, 1/8" thick*

**STICK EDGE BAND**  
*1/8" thick*

**STICK EDGE BAND**  
*1/4" thick*

**GRAIN DIRECTION:**



**VERTICAL MATCHED Standard**  
*Both drawers and doors have a vertical matched grain direction*



**COMBINATION**  
*Drawer grain direction is horizontal and door grain direction is vertical*

**BASE - CONSTRUCTION:**

**INTEGRAL WITH END PANELS,  
WITHOUT LEVELERS Standard**

**INTEGRAL WITH END PANELS,  
WITH LEVELERS**

**SEPARATE**  
*Factory attached or field furnished/ fabricated*

**REMOVABLE BASE CABINET BACK PANEL:**



**ONE PIECE TEMPERED HARDBOARD Standard**  
*One piece behind cupboard units  
Open behind drawers*



**TWO PIECE TEMPERED HARDBOARD**  
*Allows for easy access to portions of the cabinet*

**WHITE MELAMINE - 1 PIECE**  
 **VENEERED - 1 PIECE**

**WHITE MELAMINE - 2 PIECE**  
 **VENEERED - 2 PIECE**

**REMOVABLE BACK OTHER (SPECIFY)**

**FINISHED ENDS OPTION:**

The Finished Ends Option is available for any unit you wish to have finished, that is exposed. Ends where this option is not selected will be manufactured from the same species of material at a different grade level. All unfinished ends will have a sealer coat applied.

**OPTION FEB**  
*Finished Ends Both*

**OPTION FEL**  
*Finished End Left*

**OPTION FER**  
*Finished End Right*



*WOOD CASEWORK  
OPTIONS*

**Standard Options**

**EXTENDED ENDS OPTION:**

The Extended Ends Option is available in 1" increments from 1" to 9" on any unit you wish to have extended. When choosing this option change the last digit to the extended length you require. Eg: XB1 = Extended End Both of 1". This option comes standard as a finished end.

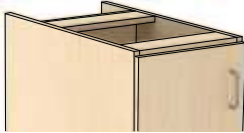

**OPTION XB7**  
Extended Ends Both



**OPTION XL7**  
Extended End Left



**OPTION XR7**  
Extended End Right

**FIXED BACK AT TALL CASE/WALL CASE/UPPER CASE ONLY (solid doors only):**

**TEMPERED HARDBOARD Standard**

**VENEER MDF CORE PLYWOOD**

**VENEERED BACK**

**DRAWER CONSTRUCTION:**

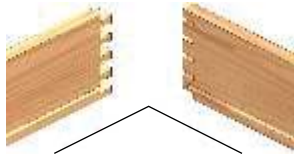

**DOVETAIL DRAWER BODIES Standard**  
All four wood sides connected by multiple dovetail joints. Sides slotted for bottom panel  
 Solid Maple Drawer Body, Option DBM

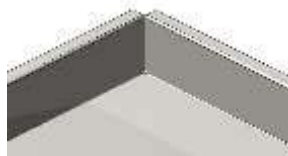

**POWDER COATED STEEL DRAWER BODIES**  
One full piece of powder coated 20ga rolled steel with reinforcing bend on all top edges



**STAINLESS STEEL DRAWER BODIES**  
Drawer with integral sides and back, constructed using 20ga 304 stainless steel with a #4 finish

**DRAWER SUSPENSION:**



**FULL EXTENSION SLIDES Standard**  
OPTION DR1 for full extension 100 lb, galvanized steel slides



**3/4 EXTENSION SLIDES**  
OPTION DR2 3/4 extension epoxy coated nylon tire slides



**FULL EXTENSION SLIDES**  
OPTION DR5 for 200lb

**CABINET SHELF DEPTH:**



**FULL DEPTH SHELF Standard**  
Measures 3/4" shorter than the inside depth of cabinet

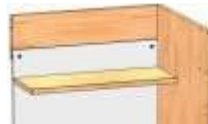

**HALF DEPTH SHELF**  
Accommodates storage of tall apparatus in front of shelf



**SPLIT DEPTH SHELF**  
Capable being a Half Depth and a Full Depth shelf

*WOOD CASEWORK  
OPTIONS*

**Standard Options**

**DRAWER/DOOR PULL DIRECTION:**



□ **CONFIGURATION 1 Standard**  
Pulls are horizontal on all drawers, and vertical on all doors



□ **CONFIGURATION 2**  
Pulls are horizontal on all drawers and doors. Floor cabinets have vertical pulls

**DRAWER/DOOR PULLS:**



□ **OPTION 62 - Standard**  
4" Brushed Aluminum Pull



□ **OPTION 61**  
4" Tubular Stainless Steel Pull  
□ **OPTION 68**  
4" Aluminum Wire Pull  
□ **OPTION 6B**  
4" Black Wire Pull



□ **OPTION 63**  
4" Chrome Pull



□ **OPTION 60**  
4" Black Nylon Pull

□ **OPTION 65**  
4" Flush Aluminum Pull

**DOOR HINGES:**



□ **OPTION 20 - Standard**  
Dull Chrome Overlay Hinge  
□ **OPTION 24**  
Stainless Steel Overlay Hinge  
□ **OPTION DH2**  
Black Overlay Hinge

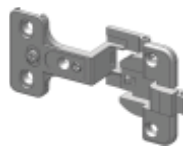

□ **OPTION 27**  
Three Knuckle Hinge



□ **OPTION 28**  
165 Degree Euro Concealed Self-Closing Hinge

**DOOR CATCHES:**



□ **ROLLER CATCH Standard**



□ **MAGNETIC CATCH**

**SHELF CLIPS:**

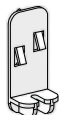

□ **PLASTIC TWIN-PIN Standard**  
Seismic suited



□ **PLATED PIN**  
Allows for easy adjustability



□ **PLASTIC SINGLE-PIN**  
Seismic suited



□ **RECESSED MOUNTING PILASTER AND CLIPS**

*WOOD CASEWORK  
OPTIONS*

**Standard Options**

**LOCK TYPE:**



**OPTION 30 Standard**  
5-Disc Master with removable core



**OPTION LK4**  
5-Pin Tumbler with removable core,  
3 level keying



**OPTION 37**  
Provisions for Hasp Lock  
(lock not included)

**SECURITY PANELS:**

**WITHOUT FRONT RAILS Standard**  
When no locks are selected

**WITH FRONT RAILS**  
When cabinets are to be keyed alike

**WITH FRONT RAILS & SECURITY PANEL**  
When cabinets are to be keyed different

**LABEL HOLDER:**

**NONE Standard**

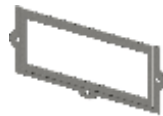

**OPTION 02**  
Label holder - one per door, one per  
drawer



**OPTION LH2**  
Label holder - File drawers only



**OPTION LH3**  
Label holder - all drawers only

**GLASS:**

**FLOAT GLASS Standard**  
3mm glass

**FLOAT GLASS with Flush Pull**  
6mm glass

**LAMINATED SAFETY GLASS**  
6mm

**TEMPERED SAFETY GLASS**  
6mm

*WOOD CASEWORK  
OPTIONS*

**Ordering Special Features**

**STEP TWO - OPTIONAL FEATURES**

Select any of the following options as the application requires.

**Option #      Description**

**Cabinet & Miscellaneous Options**

00	Required cabinet has drawer and/or door configuration similar to basic part noted. A minor configuration change is required with no changes in the cabinets outside dimensions from the basic part number specified - <i>see note 1</i>
02	Label holders on all doors/drawers
03	Numeric or alpha identification disks on all doors/drawers - <i>see note 2</i>
04	Standard louver configuration on doors - <i>see note 3</i>
05	Non-standard louver configuration on doors - <i>see note 1</i>
07	Cut-outs for electrical and/or plumbing services - <i>see note 1</i>
08	Security panel installed
09	Stainless steel waste flap
10	One drawer divider per drawer - <i>see note 12</i>
11	Multiple drawer dividers per drawer - <i>see note 1</i>
12	Pull out writing board supplied with same veneer as cabinet exterior
13	Pull out writing board supplied with high pressure laminate writing surface
14	Ventilation grill in toe kick base - <i>see note 1</i>
15	Finished back on cabinet
17	Nylon levelers
19	Full width drawer on 5" high apron
37	Provisions for hasp locks (actual locks not included)
48	Keyboard tray (replace drawer)
82	FRP liner for acid cabinets - <i>see note 4</i>
83	Self closing doors for solvent cabinets
84	Galvanized bin insert
85	PVC bin insert for waste bin units
89	Lazy susan storage unit for corner cabinets
90	Sink supports - <i>see note 6</i>
AD	Add - a - drawer design - <i>see note 15</i>
BL	"Base" label (use this option code to replace standard label on Acid cabinets)
CL	"Corrosive" label
DL	Fluorescent light for specialty recessed drawer desk unit
F1	Finished top
F2	Finished top and back
FL	Fusible Link with self closer for Insulated Solvent Unit - <i>see note 7</i>
LA	Bilingual label (English/French)
LF	Longitudinal file
NB	No base on cabinet to sit on floor
NC	No base on cabinet to sit on curb
NF	Pump Cabinet Unit with no cabinet floor and toekick is integral with door
NFD	Pump Cabinet Unit with no cabinet floor and toe kick is integral with door, dolly included
PC	Foot pedal cutouts centered
PL	Foot pedal cutout left hand side
PR	Foot pedal cutout right hand side
RB	Removable back on drawer cabinet
RL	Remote LED light for narcotic cabinet
SK	Skid item

*WOOD CASEWORK  
OPTIONS*

**Ordering Special Features**

**STEP TWO - OPTIONAL FEATURES**

Select any of the following options as the application requires.

**Option #      Description**

**Cabinet & Miscellaneous Options**

SP	Silk Screen Printing (to replace standard labels on Acid and/or Flammable cabinets)
VK	Corrugated polyolefin vent kit for acid cabinets
T1	One pull out tray on full extension runners with 1" high lip - <i>see note 16</i>
T2	Two pull out trays on full extension runners with 1" high lip - <i>see note 16</i>
T3	Three pull out trays on full extension runners with 1" high lip - <i>see note 16</i>
40	One extra cabinet shelf - <i>see note 5</i>
41	Two extra cabinet shelves - <i>see note 5</i>
42	One interior cabinet shelf on full extension runners - <i>see note 13</i>
43	Two interior cabinet shelves on full extension runners - <i>see note 13</i>
44	Three interior cabinet shelves on full extension runners - <i>see note 13</i>

**Wall Cabinet Options**

SL	Seismic lip
DS	Double sided wall cabinet

**Floor Cabinet Options**

80	Full height doors for floor cabinets
81	Coat rod for wardrobe for floor cabinets

**Shelf Options - See page N8**

**Glass Options**

45	DuoLite safety glass - <i>see note 11</i>
46	Tempered glass - <i>see note 11</i>
47	Customer specified glass - <i>see note 8</i>
4A	Glass Tint 44% (Grey Smoke)
GL1	3mm float glass

**Base Cabinet Options**

70	Front toe kick
71	Toe kick - front & left side - <i>see note 14</i>
72	Toe kick - front & right side - <i>see note 14</i>
73	Toe kick - front & 2 sides - <i>see note 14</i>
74	Toe kick - front & back - <i>see note 14</i>
75	Toe kick - front, back, & 2 sides - <i>see note 14</i>
76	Replace toe kick base with 4 legs
77	Replace cabinet toe kick base with casters and tip prevention counterweights (casters & hardware shipped loose)
78	Replace cabinet toe kick base with customer specified casters - <i>see note 8</i>
79	Other customer specified base and/or toe kick - <i>see note 1</i>

*WOOD CASEWORK  
OPTIONS*

**Ordering Special Features**

**STEP TWO - OPTIONAL FEATURES**

Select any of the following options as the application requires.

<u>Option #</u>	<u>Description</u>
<b>Table Options</b>	
06	One fixed shelf on "O" frame tables
48	Keyboard tray (replaces drawer)
49	Wood leg with stainless steel adjustable height inserts. Legs are adjustable in 1" increments, from 28-3/4" high to 34-3/4" high.
87	Mobile table complete with casters - <i>see note 10</i>
88	Mobile table complete with customer specified casters - <i>see note 8</i>
91	Table with no supports
92	"U" frame style table with rear & side supports
93	Left side leg table - no supports
94	Right side leg table - no supports
95	Front table legs - no supports

**EXPLANATORY NOTES FOR OPTION CODES**

1. Full dimensional and descriptive details (preferably including a sketch) must be included with the order.
2. Full descriptive details must be included with the order.
3. Standard louver configuration is one block of 6 louvers located near the bottom center of each door, each louver is approximately 3" wide by 5-1/2" long.
4. Use this option code to have cabinet lined with FRP instead of molded liner.
5. Standard number of removable shelves per base cabinet with door(s) or wall cabinet is noted in the cabinet drawings of this catalog.
6. Sink support kit is required for under-counter mounted sinks used with Imperial Stone or Epoxy counter tops. Sink support kit not normally required for self rimming or integrally welded sinks.
7. Designed for use on solvent cabinets (-83). A fusible link holds doors open during use and melts at 165°F to automatically close doors in the event of a fire.
8. Provide complete specification and source for all special option ordered.
9. Standard lock is a 5 pin disc lock. Every lock on every cabinet on order will be keyed alike unless otherwise specified.
10. Standard 4" high casters are swivel with rolling brake.
11. Standard glass is as follows:
 

All framed glass and sliding glass Floor Cabinets	1/4" (6mm) float glass
Sliding glass door Wall Cabinets	1/4" (6mm) float glass
Framed glass door Wall Cabinets	1/8" (3mm) float glass
12. Drawer divider runs depth of drawer.
13. Pull out shelves replace standard removable shelf in base cabinets with door(s).
14. Cabinet left and right are determined when facing the cabinet front.
15. Removable top drawer unit is 6" high.
16. Pull out tray replaces standard removable shelf in base cabinets with door(s). Tray is not removable.

*WOOD CASEWORK  
OPTIONS*

**Ordering Double Sided Wall Units**

Mott laboratory furniture is available with a wide variety of features to meet specific application requirements. The full range of our Mott wall cabinets are available in our double sided design. To specify double sided wall cabinets, select the two digit part number suffix from below and add this suffix after the standard part number, separated with a dash.

**OVERVIEW EXAMPLE**

To order double sided wall cabinets.

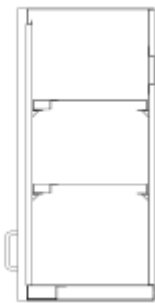
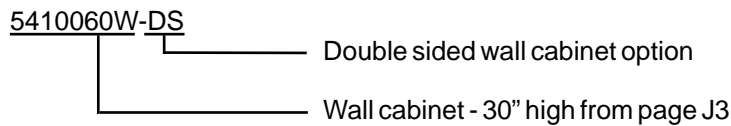

5410060W



**Note:** Steel cabinet drawings shown.

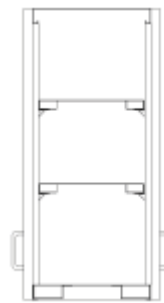

5410060W-DS

**Ordering Special Features**

Mott laboratory furniture is available with a wide variety of features to meet specific application requirements. To specify any feature, select the two or three digit option code suffix from the list below and add this suffix after the standard part number, separated with a dash.

**OVERVIEW EXAMPLE**

To order chrome hinges, brushed aluminum pulls, and a pull-out shelf on a drawer/door cabinet.

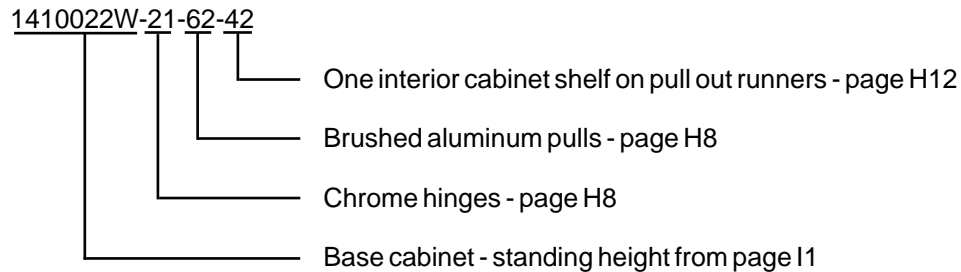

*WOOD CASEWORK  
OPTIONS*

**Lock and Key Options**

**All Locks Keyed Different Per Unit**

Locks are keyed different per unit from other units.

Note: This is the standard key schedule with disc tumbler lock supplied for option code 30 unless otherwise specified.

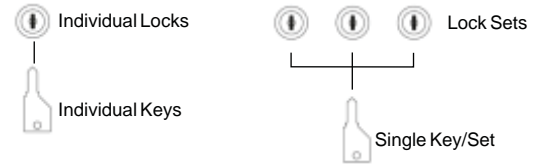

**All Locks Keyed Alike**

All locks are keyed alike, each lock can be opened with a single key.

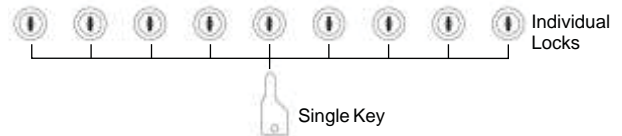

**All Locks Keyed Different**

Locks are keyed different from other locks. Up to 229 key changes for disc are available.

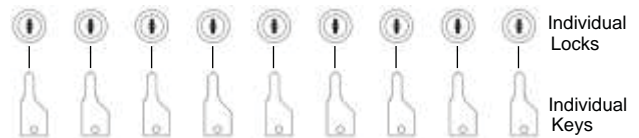

**Locks Keyed Alike in Sets**

Locks are keyed alike in sets. Only one key will open one set of locks within the set. Up to 229 key changes for disc are available.

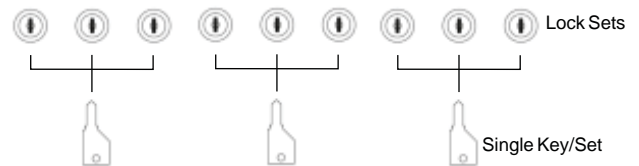

**Master Keyed Locks**

All locks are keyed different from all other locks. Each set within a group can be opened with a master key. Up to 229 key changes for disc are available.

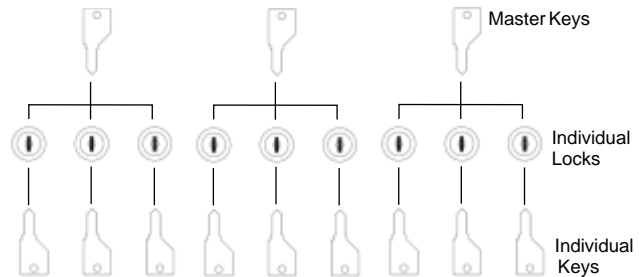

**All Pin Locks Keyed Different - Grand Master & Master Keyed**

All locks are keyed different from all other locks. Each set within a group can be opened with a master key. All groups can be opened with a grand master key. Grand Master only available in pin style locks.

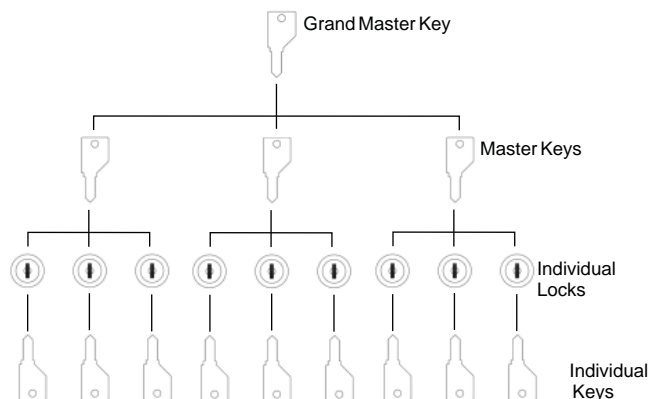



*WOOD CASEWORK  
BASE CABINETS - STANDING HEIGHT*



**Open Units**



Width	Item Number
12"	1010000W
15"	1910000W
18"	1110000W
24"	1210000W
30"	1310000W
36"	1410000W
42"	1810000W
48"	1510000W
513mm	1610000W
1000mm	1710000W

• Actual depths 7/8" less than nominal.

**Full Door Units**



up to 24" wide



30" and wider

Width	Right Hinged	Left Hinged	# of Doors
12"	1010011W	1010211W	1
15"	1910011W	1910211W	1
18"	1110011W	1110211W	1
24"	1210011W	1210211W	1
30"	1310011W	-	2
36"	1410011W	-	2
42"	1810011W	-	2
48"	1510011W	-	2
513mm	1610011W	1610211W	1
1000mm	1710011W	-	2

**Door/Drawer Units**



up to 24" wide



30" and wider

Width	Right Hinged	Left Hinged	# of Doors
12"	1010022W	1010222W	1
15"	1910022W	1910222W	1
18"	1110022W	1110222W	1
24"	1210022W	1210222W	1
30"	1310022W	-	2
36"	1410022W	-	2
42"	1810022W	-	2
48"	1510022W	-	2
513mm	1610022W	1610222W	1
1000mm	1710022W	-	2



up to 24" wide



30" and wider

Width	Right Hinged	Left Hinged	# of Doors
12"	1010033W	1010233W	1
15"	1910033W	1910233W	1
18"	1110033W	1110233W	1
24"	1210033W	1210233W	1
30"	1310033W	-	2
36"	1410033W	-	2
42"	1810033W	-	2
48"	1510033W	-	2
513mm	1610033W	1610233W	1
1000mm	1710033W	-	2

*WOOD CABINETS  
BASE CABINETS - STANDING HEIGHT*

**Door/Drawer Units**



Width	Item Number
30"	1310093W
36"	1410093W
42"	1810093W
48"	1510093W
1000mm	1710093W



Width	Item Number
30"	1310096W
36"	1410096W
42"	1810096W
48"	1510096W
1000mm	1710096W



Width	Left Hand	Right Hand
30"	1310023W	1310032W
36"	1410023W	1410032W
42"	1810023W	1810032W
48"	1510023W	1510032W
1000mm	1710023W	1710032W

- Left hand Door/Drawer Unit shown.
- Right hand Door/Drawer Units are reverse of what is shown.



Width	Left Hand	Right Hand
30"	1310012W	1310021W
36"	1410012W	1410021W
42"	1810012W	1810021W
48"	1510012W	1510021W
1000mm	1710012W	1710021W

- Left hand Door/Drawer Unit shown.
- Right hand Door/Drawer Units are reverse of what is shown.



Width	Left Hand	Right Hand
30"	1310013W	1310031W
36"	1410013W	1410031W
42"	1810013W	1810031W
48"	1510013W	1510031W
1000mm	1710013W	1710031W

- Left hand Door/Drawer Unit shown.
- Right hand Door/Drawer Units are reverse of what is shown.

*WOOD CASEWORK  
BASE CABINETS - STANDING HEIGHT*

**Door/Drawer Units**

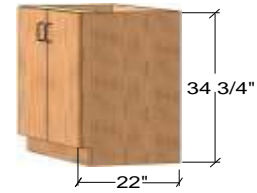

Width	Left Hand	Right Hand
30"	1310014W	1310041W
36"	1410014W	1410041W
42"	1810014W	1810041W
48"	1510014W	1510041W
1000mm	1710014W	1710041W

- Left hand Door/Drawer Unit shown.
- Right hand Door/Drawer Units are reverse of what is shown.



Width	Left Hand	Right Hand
30"	1310015W	1310051W
36"	1410015W	1410051W
42"	1810015W	1810051W
48"	1510015W	1510051W
1000mm	1710015W	1710051W

- Left hand Door/Drawer Unit shown.
- Right hand Door/Drawer Units are reverse of what is shown.



Width	Left Hand	Right Hand
30"	1310016W	1310061W
36"	1410016W	1410061W
42"	1810016W	1810061W
48"	1510016W	1510061W
1000mm	1710016W	1710061W

- Left hand Door/Drawer Unit shown.
- Right hand Door/Drawer Units are reverse of what is shown.



Width	Left Hand	Right Hand
30"	1310017W	1310071W
36"	1410017W	1410071W
42"	1810017W	1810071W
48"	1510017W	1510071W
1000mm	1710017W	1710071W

- Left hand Door/Drawer Unit shown.
- Right hand Door/Drawer Units are reverse of what is shown.



Width	Left Hand	Right Hand
30"	131001BW	13100B1W
36"	141001BW	14100B1W
42"	181001BW	18100B1W
48"	151001BW	15100B1W
1000mm	171001BW	17100B1W

- Left hand Door/Drawer Unit shown.
- Right hand Door/Drawer Units are reverse of what is shown.

*WOOD CABINETS  
BASE CABINETS - STANDING HEIGHT*

**Door/Drawer Units**

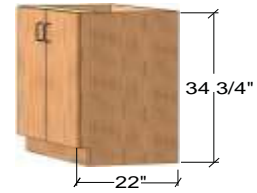

Width	Left Hand	Right Hand
30"	1310924W	1310942W
36"	1410924W	1410942W
42"	1810924W	1810942W
48"	1510924W	1510942W
1000mm	1710924W	1710942W

- Left hand Door/Drawer Unit shown.
- Right hand Door/Drawer Units are reverse of what is shown.



Width	Left Hand	Right Hand
30"	1310024W	1310042W
36"	1410024W	1410042W
42"	1810024W	1810042W
48"	1510024W	1510042W
1000mm	1710024W	1710042W

- Left hand Door/Drawer Unit shown.
- Right hand Door/Drawer Units are reverse of what is shown.



Width	Left Hand	Right Hand
30"	1310025W	1310052W
36"	1410025W	1410052W
42"	1810025W	1810052W
48"	1510025W	1510052W
1000mm	1710025W	1710052W

- Left hand Door/Drawer Unit shown.
- Right hand Door/Drawer Units are reverse of what is shown.



Width	Left Hand	Right Hand
30"	1310026W	1310062W
36"	1410026W	1410062W
42"	1810026W	1810062W
48"	1510026W	1510062W
1000mm	1710026W	1710062W

- Left hand Door/Drawer Unit shown.
- Right hand Door/Drawer Units are reverse of what is shown.



Width	Left Hand	Right Hand
30"	1310027W	1310072W
36"	1410027W	1410072W
42"	1810027W	1810072W
48"	1510027W	1510072W
1000mm	1710027W	1710072W

- Left hand Door/Drawer Unit shown.
- Right hand Door/Drawer Units are reverse of what is shown.

*WOOD CASEWORK  
BASE CABINETS - STANDING HEIGHT*

**Door/Drawer Units**

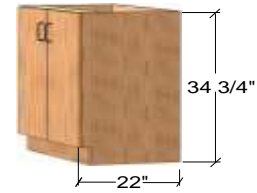

Width	Left Hand	Right Hand
30"	1310034W	1310043W
36"	1410034W	1410043W
42"	1810034W	1810043W
48"	1510034W	1510043W
1000mm	1710034W	1710043W

- Left hand Door/Drawer Unit shown.
- Right hand Door/Drawer Units are reverse of what is shown.



Width	Left Hand	Right Hand
30"	1310035W	1310053W
36"	1410035W	1410053W
42"	1810035W	1810053W
48"	1510035W	1510053W
1000mm	1710035W	1710053W

- Left hand Door/Drawer Unit shown.
- Right hand Door/Drawer Units are reverse of what is shown.



Width	Left Hand	Right Hand
30"	1310036W	1310063W
36"	1410036W	1410063W
42"	1810036W	1810063W
48"	1510036W	1510063W
1000mm	1710036W	1710063W

- Left hand Door/Drawer Unit shown.
- Right hand Door/Drawer Units are reverse of what is shown.



Width	Left Hand	Right Hand
30"	1310037W	1310073W
36"	1410037W	1410073W
42"	1810037W	1810073W
48"	1510037W	1510073W
1000mm	1710037W	1710073W

- Left hand Door/Drawer Unit shown.
- Right hand Door/Drawer Units are reverse of what is shown.



*WOOD CABINETS  
BASE CABINETS - STANDING HEIGHT*

**Drawer Units**



up to 24" wide



30" and wider

Width	Item Number
12"	1010044W
15"	1910044W
18"	1110044W
24"	1210044W
30"	1310044W
36"	1410044W
42"	1810044W
48"	1510044W
513mm	1610044W
1000mm	1710044W



up to 24" wide



30" and wider

Width	Item Number
15"	1910055W
18"	1110055W
24"	1210055W
30"	1310055W
36"	1410055W
42"	1810055W
48"	1510055W
513mm	1610055W
1000mm	1710055W



up to 24" wide



30" and wider

Width	Item Number
15"	1910066W
18"	1110066W
24"	1210066W
30"	1310066W
36"	1410066W
42"	1810066W
48"	1510066W
513mm	1610066W
1000mm	1710066W



up to 24" wide



30" and wider

Width	Item Number
15"	1910077W
18"	1110077W
24"	1210077W
30"	1310077W
36"	1410077W
42"	1810077W
48"	1510077W
513mm	1610077W
1000mm	1710077W



up to 24" wide



30" and wider

Width	Item Number
15"	19100BBW
18"	11100BBW
24"	12100BBW
30"	13100BBW
36"	14100BBW
42"	18100BBW
48"	15100BBW
513mm	16100BBW
1000mm	17100BBW

All dimensions and sizes shown are nominal. Specifications and details are based on product information at the time of printing and may change at any time without notice. Mott Manufacturing reserves the right to change dimensions, specifications and manufacturing details at any time without notice.

*WOOD CASEWORK  
BASE CABINETS - STANDING HEIGHT*

**Drawer Units**



up to 24" wide



30" and wider

Width	Item Number
15"	1910090W
18"	1110090W
24"	1210090W
30"	13100NNW
36"	14100NNW
42"	18100NNW
48"	15100NNW
513mm	1610090W
1000mm	17100NNW



Width	Item Number
30"	1310A91W
36"	1410A91W
42"	1810A91W
48"	1510A91W
1000mm	1710A91W



Width	Item Number
30"	1310090W
36"	1410090W
42"	1810090W
48"	1510090W
513mm	1610090W



Width	Item Number
30"	1310097W
36"	1410097W
42"	1810097W
48"	1510097W
1000mm	1710097W



Width	Item Number
30"	1310098W
36"	1410098W
42"	1810098W
48"	1510098W
1000mm	1710098W



*WOOD CABINETS  
BASE CABINETS - STANDING HEIGHT*

**Drawer Units**



Width	Item Number
30"	1310091W
36"	1410091W
42"	1810091W
48"	1510091W
1000mm	1710091W



Width	Item Number
30"	1310099W
36"	1410099W
42"	1810099W
48"	1510099W
1000mm	1710099W



Width	Item Number
30"	1310B44W
36"	1410B44W
42"	1810B44W
48"	1510B44W
1000mm	1710B44W



Width	Item Number
30"	1310094W
36"	1410094W
42"	1810094W
48"	1510094W
1000mm	1710094W



Width	Item Number
30"	1310092W
36"	1410092W
42"	1810092W
48"	1510092W
1000mm	1710092W





*WOOD CASEWORK  
BASE CABINETS - STANDING HEIGHT*

**Drawer Units**



Width	Item Number
30"	1310095W
36"	1410095W
42"	1810095W
48"	1510095W
1000mm	1710095W



Width	Left Hand	Right Hand
30"	1310029W	1310019W
36"	1410029W	1410019W
42"	1810029W	1810019W
48"	1510029W	1510019W
1000mm	1710029W	1710019W

- Left hand Drawer Unit shown.
- Right hand Drawer Units are reverse of what is shown.



Width	Item Number
30"	1310039W
36"	1410039W
42"	1810039W
48"	1510039W
1000mm	1710039W



Width	Item Number
30"	13100CCW
36"	14100CCW
42"	18100CCW
48"	15100CCW
1000mm	17100CCW

**File Drawer Units**



up to 24" wide



30" and wider

Width	Item Number
12"	1A10133W
15"	1910133W
18"	1110133W
24"	1210133W
30"	1310133W
36"	1410133W
42"	1810133W
48"	1510133W
513mm	1610133W
1000mm	1710133W



*WOOD CABINETS*  
*BASE CABINETS - STANDING HEIGHT*

**File Drawer Units**



up to 24" wide



30" and wider

Width	Item Number
15"	1910100W
18"	1110100W
24"	1210100W
30"	1310100W
36"	1410100W
42"	1810100W
48"	1510100W
513mm	1610100W
1000mm	1710100W



up to 24" wide



30" and wider

Width	Item Number
15"	1910111W
18"	1110111W
24"	1210111W
30"	1310111W
36"	1410111W
42"	1810111W
48"	1510111W
513mm	1610111W
1000mm	1710111W



up to 24" wide



30" and wider

Width	Item Number
15"	1910122W
18"	1110122W
24"	1210122W
30"	1310122W
36"	1410122W
42"	1810122W
48"	1510122W
513mm	1610122W
1000mm	1710122W



up to 24" wide



30" and wider

Width	Item Number
15"	19101AAW
18"	11101AAW
24"	12101AAW
30"	13101AAW
36"	14101AAW
42"	18101AAW
48"	15101AAW
513mm	16101AAW
1000mm	17101AAW

*WOOD CASEWORK  
BASE CABINETS - STANDING HEIGHT*

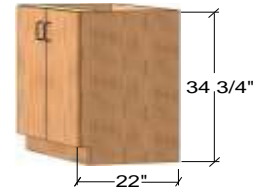

**Control Panel Units**



up to 24" wide



30" and wider

Width	Right Hinged	Left Hinged	# of Doors
12"	1015022W	1015222W	1
15"	1915022W	1915222W	1
18"	1115022W	1115222W	1
24"	1215022W	1215222W	1
30"	1315022W	-	2
36"	1415022W	-	2
42"	1815022W	-	2
48"	1515022W	-	2
513mm	1615022W	1615222W	1
1000mm	1715022W	-	2

**Sliding Door Units**



Width	Item Number
30"	1310711W
36"	1410711W
42"	1810711W
48"	1510711W
1000mm	1710711W

**Waste/Storage Bin Units**



up to 24" wide



30" and wider

Width	Item Number	# of Bins
15"	1910500W	1
18"	1110500W	1
24"	1210500W	1
30"	1310500W	2
36"	1410500W	2
42"	1810500W	2
48"	1510500W	2
513mm	1610500W	1
1000mm	1710500W	2

- Galvanized bin insert is not included with Waste/Storage Bin Units.
- Tilt out door is hinged at the bottom.

**Corner Units**

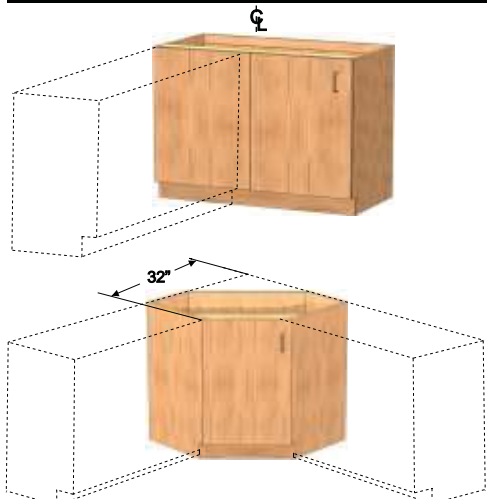

Width	Door On Right	Door On Left
30"	1310311W	1310411W
36"	1410311W	1410411W
42"	1810311W	1810411W
48"	1510311W	1510411W
1000mm	1710311W	1710411W

- Right Door Corner Unit shown.
- Left Door Corner Units are reverse of what is shown.
- Center stile is located at the middle point.

Description	Right Hinged	Left Hinged
Full Door Unit	1017011W	1017111W
False Panel Unit	1017422W	1017922W

- Left Hinge, full door Corner Unit shown.
- Overall depth of this unit is 26" from the front of the door to the back of the cabinet.
- Add Option Code 89 to order a Lazy Susan .

*WOOD CABINETS  
BASE CABINETS - SITTING HEIGHT*

**Open Units**

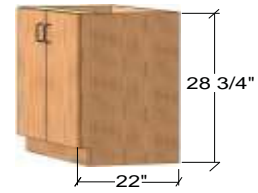

Width	Item Number
12"	1020000W
15"	1920000W
18"	1120000W
24"	1220000W
30"	1320000W
36"	1420000W
42"	1820000W
48"	1520000W
513mm	1620000W
1000mm	1720000W

• Actual depths 7/8" less than nominal.

**Full Door Units**



up to 24" wide



30" and wider

Width	Right Hinged	Left Hinged	# of Doors
12"	1020011W	1020211W	1
15"	1920011W	1920211W	1
18"	1120011W	1120211W	1
24"	1220011W	1220211W	1
30"	1320011W	-	2
36"	1420011W	-	2
42"	1820011W	-	2
48"	1520011W	-	2
513mm	1620011W	1620211W	1
1000mm	1720011W	-	2

**Door/Drawer Units**



up to 24" wide



30" and wider

Width	Right Hinged	Left Hinged	# of Doors
12"	1020022W	1020222W	1
15"	1920022W	1920222W	1
18"	1120022W	1120222W	1
24"	1220022W	1220222W	1
30"	1320022W	-	2
36"	1420022W	-	2
42"	1820022W	-	2
48"	1520022W	-	2
513mm	1620022W	1620222W	1
1000mm	1720022W	-	2



up to 24" wide



30" and wider

Width	Right Hinged	Left Hinged	# of Doors
15"	1920033W	1920233W	1
18"	1120033W	1120233W	1
24"	1220033W	1220233W	1
30"	1320033W	-	2
36"	1420033W	-	2
42"	1820033W	-	2
48"	1520033W	-	2
513mm	1620033W	1620233W	1
1000mm	1720033W	-	2

*WOOD CASEWORK  
BASE CABINETS - SITTING HEIGHT*

**Door/Drawer Units**

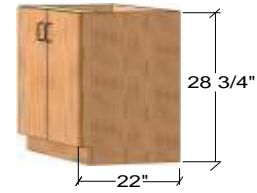

Width	Item Number
30"	1320093W
36"	1420093W
42"	1820093W
48"	1520093W
1000mm	1720093W



Width	Item Number
30"	1320096W
36"	1420096W
42"	1820096W
48"	1520096W
1000mm	1720096W



Width	Left Hand	Right Hand
30"	1320023W	1320032W
36"	1420023W	1420032W
42"	1820023W	1820032W
48"	1520023W	1520032W
1000mm	1720023W	1720032W

- Left hand Door/Drawer Unit shown.
- Right hand Door/Drawer Units are reverse of what is shown.



Width	Left Hand	Right Hand
30"	1320012W	1320021W
36"	1420012W	1420021W
42"	1820012W	1820021W
48"	1520012W	1520021W
1000mm	1720012W	1720021W

- Left hand Drawer Unit shown.
- Right hand Drawer Units are reverse of what is shown.



Width	Left Hand	Right Hand
30"	1320013W	1320031W
36"	1420013W	1420031W
42"	1820013W	1820031W
48"	1520013W	1520031W
1000mm	1720013W	1720031W

- Left hand Door/Drawer Unit shown.
- Right hand Door/Drawer Units are reverse of what is shown.





*WOOD CABINETS  
BASE CABINETS - SITTING HEIGHT*

**Door/Drawer Units**

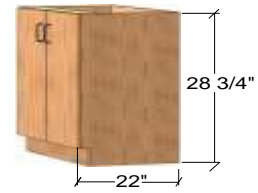

Width	Left Hand	Right Hand
30"	1320014W	1320041W
36"	1420014W	1420041W
42"	1820014W	1820041W
48"	1520014W	1520041W
1000mm	1720014W	1720041W

- Left hand Door/Drawer Unit shown.
- Right hand Door/Drawer Units are reverse of what is shown.



Width	Left Hand	Right Hand
30"	1320015W	1320051W
36"	1420015W	1420051W
42"	1820015W	1820051W
48"	1520015W	1520051W
1000mm	1720015W	1720051W

- Left hand Door/Drawer Unit shown.
- Right hand Door/Drawer Units are reverse of what is shown.



Width	Left Hand	Right Hand
30"	1320016W	1320061W
36"	1420016W	1420061W
42"	1820016W	1820061W
48"	1520016W	1520061W
1000mm	1720016W	1720061W

- Left hand Door/Drawer Unit shown.
- Right hand Door/Drawer Units are reverse of what is shown.



Width	Left Hand	Right Hand
30"	1320924W	1320942W
36"	1420924W	1420942W
42"	1820924W	1820942W
48"	1520924W	1520942W
1000mm	1720924W	1720942W

- Left hand Door/Drawer Unit shown.
- Right hand Door/Drawer Units are reverse of what is shown.



Width	Left Hand	Right Hand
30"	1320024W	1320042W
36"	1420024W	1420042W
42"	1820024W	1820042W
48"	1520024W	1520042W
1000mm	1720024W	1720042W

- Left hand Door/Drawer Unit shown.
- Right hand Door/Drawer Units are reverse of what is shown.

*WOOD CASEWORK  
BASE CABINETS - SITTING HEIGHT*

**Door/Drawer Units**

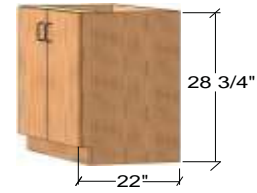

Width	Left Hand	Right Hand
30"	1320025W	1320052W
36"	1420025W	1420052W
42"	1820025W	1820052W
48"	1520025W	1520052W
1000mm	1720025W	1720052W

- Left hand Door/Drawer Unit shown.
- Right hand Door/Drawer Units are reverse of what is shown.



Width	Left Hand	Right Hand
30"	1320026W	1320062W
36"	1420026W	1420062W
42"	1820026W	1820062W
48"	1520026W	1520062W
1000mm	1720026W	1720062W

- Left hand Door/Drawer Unit shown.
- Right hand Door/Drawer Units are reverse of what is shown.



Width	Left Hand	Right Hand
30"	1320034W	1320043W
36"	1420034W	1420043W
42"	1820034W	1820043W
48"	1520034W	1520043W
1000mm	1720034W	1720043W

- Left hand Door/Drawer Unit shown.
- Right hand Door/Drawer Units are reverse of what is shown.



Width	Left Hand	Right Hand
30"	1320035W	1320053W
36"	1420035W	1420053W
42"	1820035W	1820053W
48"	1520035W	1520053W
1000mm	1720035W	1720053W

- Left hand Door/Drawer Unit shown.
- Right hand Door/Drawer Units are reverse of what is shown.



Width	Left Hand	Right Hand
30"	1320036W	1320063W
36"	1420036W	1420063W
42"	1820036W	1820063W
48"	1520036W	1520063W
1000mm	1720036W	1720063W

- Left hand Door/Drawer Unit shown.
- Right hand Door/Drawer Units are reverse of what is shown.

*WOOD CABINETS  
BASE CABINETS - SITTING HEIGHT*

**Drawer Units**

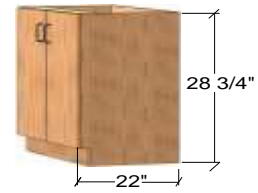

up to 24" wide



30" and wider

Width	Item Number
15"	1920044W
18"	1120044W
24"	1220044W
30"	1320044W
36"	1420044W
42"	1820044W
48"	1520044W
513mm	1620044W
1000mm	1720044W



up to 24" wide



30" and wider

Width	Item Number
15"	1920055W
18"	1120055W
24"	1220055W
30"	1320055W
36"	1420055W
42"	1820055W
48"	1520055W
513mm	1620055W
1000mm	1720055W



up to 24" wide



30" and wider

Width	Item Number
15"	1920066W
18"	1120066W
24"	1220066W
30"	1320066W
36"	1420066W
42"	1820066W
48"	1520066W
513mm	1620066W
1000mm	1720066W



Width	Item Number
30"	1320097W
36"	1420097W
42"	1820097W
48"	1520097W
1000mm	1720097W



Width	Item Number
30"	1320098W
36"	1420098W
42"	1820098W
48"	1520098W
1000mm	1720098W



*WOOD CASEWORK  
BASE CABINETS - SITTING HEIGHT*

**Drawer Units**

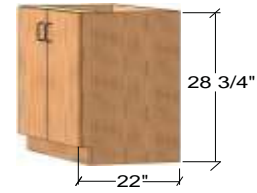

Width	Item Number
30"	1320091W
36"	1420091W
42"	1820091W
48"	1520091W
1000mm	1720091W



Width	Item Number
30"	1320099W
36"	1420099W
42"	1820099W
48"	1520099W
1000mm	1720099W



Width	Item Number
30"	1320094W
36"	1420094W
42"	1820094W
48"	1520094W
1000mm	1720094W



Width	Item Number
30"	1320092W
36"	1420092W
42"	1820092W
48"	1520092W
1000mm	1720092W



Width	Item Number
30"	1320095W
36"	1420095W
42"	1820095W
48"	1520095W
1000mm	1720095W

*WOOD CABINETS  
BASE CABINETS - SITTING HEIGHT*

**Drawer Units**

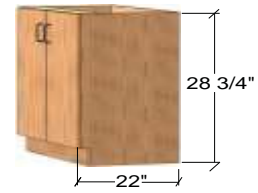

Width	Item Number
30"	1320B44W
36"	1420B44W
42"	1820B44W
48"	1520B44W
1000mm	1720B44W

**File Drawer Units**



up to 24" wide



30" and wider

Width	Item Number
15"	1920122W
18"	1120122W
24"	1220122W
30"	1320122W
36"	1420122W
42"	1820122W
48"	1520122W
513mm	1620122W
1000mm	1720122W



up to 24" wide



30" and wider

Width	Item Number
15"	1920177W
18"	1120177W
24"	1220177W
30"	1320177W
36"	1420177W
42"	1820177W
48"	1520177W
513mm	1620177W
1000mm	1720177W



up to 24" wide



30" and wider

Width	Item Number
15"	1920188W
18"	1120188W
24"	1220188W
30"	1320188W
36"	1420188W
42"	1820188W
48"	1520188W
513mm	1620188W
1000mm	1720188W

*WOOD CASEWORK  
BASE CABINETS - SITTING HEIGHT*

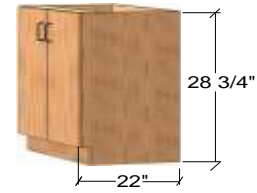

**Control Panel Units**



up to 24" wide



30" and wider

Width	Right Hinged	Left Hinged	# of Doors
12"	1025022W	1025222W	1
15"	1925022W	1925222W	1
18"	1125022W	1125222W	1
24"	1225022W	1225222W	1
30"	1325022W	-	2
36"	1425022W	-	2
42"	1825022W	-	2
48"	1525022W	-	2
513mm	1625022W	1625222W	1
1000mm	1725022W	-	2

**Sliding Door Units**



Width	Item Number
30"	1320711W
36"	1420711W
42"	1820711W
48"	1520711W
1000mm	1720711W

**Waste/Storage Bin Units**



up to 24" wide



30" and wider

Width	Item Number	# of Bins
15"	1920500W	1
18"	1120500W	1
24"	1220500W	1
30"	1320500W	2
36"	1420500W	2
42"	1820500W	2
48"	1520500W	2
513mm	1620500W	1
1000mm	1720500W	2

- Galvanized bin insert is not included with Waste/Storage Bin Units.
- Tilt out door is hinged at the bottom.

**Corner Units**

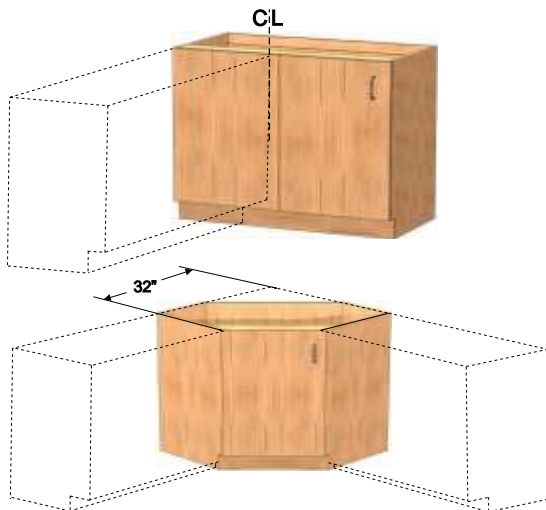

Width	Door On Right	Door On Left
30"	1320311W	1320411W
36"	1420311W	1420411W
42"	1820311W	1820411W
48"	1520311W	1520411W
1000mm	1720311W	1720411W

- Right Door Corner Unit shown.
- Left Door Corner Units are reverse of what is shown.
- Center stile is located at the middle point.

Description	Right Hinged	Left Hinged
Full Door Unit	1027011W	1027111W
False Panel Unit	1027422W	1027922W

- Left Hinge, full door Corner Unit shown.
- Overall depth of this unit is 26" from the front of the door to the back of the cabinet.
- Add Option Code 89 to order a Lazy Susan .

*WOOD CABINETS  
BASE CABINETS - ADA HEIGHT*

**Open Units**

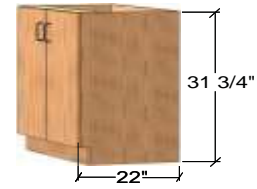

Width	Item Number
12"	1080000W
15"	1980000W
18"	1180000W
24"	1280000W
30"	1380000W
36"	1480000W
42"	1880000W
48"	1580000W
513mm	1680000W
1000mm	1780000W

- Actual depths 7/8" less than nominal.

**Full Door Units**



up to 24" wide



30" and wider

Width	Right Hinged	Left Hinged	# of Doors
12"	1080011W	1080211W	1
15"	1980011W	1980211W	1
18"	1180011W	1180211W	1
24"	1280011W	1280211W	1
30"	1380011W	-	2
36"	1480011W	-	2
42"	1880011W	-	2
48"	1580011W	-	2
513mm	1680011W	1680211W	1
1000mm	1780011W	-	2

**Door/Drawer Units**



up to 24" wide



30" and wider

Width	Right Hinged	Left Hinged	# of Doors
12"	1080022W	1080222W	1
15"	1980022W	1980222W	1
18"	1180022W	1180222W	1
24"	1280022W	1280222W	1
30"	1380022W	-	2
36"	1480022W	-	2
42"	1880022W	-	2
48"	1580022W	-	2
513mm	1680022W	1680222W	1
1000mm	1780022W	-	2



Width	Left Hand	Right Hand
30"	1380924W	1380942W
36"	1480924W	1480942W
42"	1880924W	1880942W
48"	1580924W	1580942W
1000mm	1780924W	1780942W

- Left hand Door/Drawer Unit shown.
- Right hand Door/Drawer Units are reverse of what is shown.

Width	Left Hand	Right Hand
30"	1380024W	1380042W
36"	1480024W	1480042W
42"	1880024W	1880042W
48"	1580024W	1580042W
1000mm	1780024W	1780042W

- Left hand Door/Drawer Unit shown.
- Right hand Door/Drawer Units are reverse of what is shown.

*WOOD CASEWORK  
BASE CABINETS - ADA HEIGHT*

**Drawer Units**

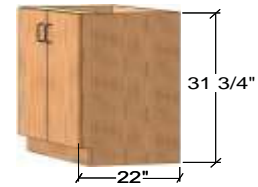

up to 24" wide



30" and wider

Width	Item Number
15"	1980090W
18"	1180090W
24"	1280090W
30"	13800NNW
36"	14800NNW
42"	18800NNW
48"	15800NNW
513mm	1680090W
1000mm	17800NNW



up to 24" wide



30" and wider

Width	Item Number
12"	1080044W
15"	1980044W
18"	1180044W
24"	1280044W
30"	1380044W
36"	1480044W
42"	1880044W
48"	1580044W
513mm	1680044W
1000mm	1780044W



up to 24" wide



30" and wider

Width	Item Number
15"	1980055W
18"	1180055W
24"	1280055W
30"	1380055W
36"	1480055W
42"	1880055W
48"	1580055W
513mm	1680055W
1000mm	1780055W



Width	Item Number
30"	1380090W
36"	1480090W
42"	1880090W
48"	1580090W
1000mm	1780090W



Width	Item Number
30"	1380097W
36"	1480097W
42"	1880097W
48"	1580097W
1000mm	1780097W



Width	Item Number
30"	1380099W
36"	1480099W
42"	1880099W
48"	1580099W
1000mm	1780099W



*WOOD CABINETS  
BASE CABINETS - ADA HEIGHT*

**File Drawer Units**



up to 24" wide



30" and wider

Width	Item Number
15"	1980100W
18"	1180100W
24"	1280100W
30"	1380100W
36"	1480100W
42"	1880100W
48"	1580100W
513mm	1680100W
1000mm	1780100W



up to 24" wide



30" and wider

Width	Item Number
15"	1980111W
18"	1180111W
24"	1280111W
30"	1380111W
36"	1480111W
42"	1880111W
48"	1580111W
513mm	1680111W
1000mm	1780111W

**Control Panel Units**



up to 24" wide



30" and wider

Width	Right Hinged	Left Hinged	# of Doors
12"	1085022W	1085222W	1
15"	1985022W	1985222W	1
18"	1185022W	1185222W	1
24"	1285022W	1285222W	1
30"	1385022W	-	2
36"	1485022W	-	2
42"	1885022W	-	2
48"	1585022W	-	2
513mm	1685022W	1685222W	1
1000mm	1785022W	-	2

**Sliding Door Units**



Width	Item Number
30"	1380711W
36"	1480711W
42"	1880711W
48"	1580711W
1000mm	1780711W

*WOOD CASEWORK  
BASE CABINETS - STANDING HEIGHT*

**Sink Units**



up to 24" wide



30" and wider

Width	Right Hinged	Left Hinged	# of Doors
12"	1013011W	1013211W	1
15"	1913011W	1913211W	1
18"	1113011W	1113211W	1
24"	1213011W	1213211W	1
30"	1313011W	-	2
36"	1413011W	-	2
42"	1813011W	-	2
48"	1513011W	-	2
513mm	1613011W	1613211W	1
1000mm	1713011W	-	2

- Add Option Code 90 to order Sink Hanger Supports.



up to 24" wide



30" and wider

Width	Right Hinged	Left Hinged	# of Doors
12"	1018022W	1018222W	1
15"	1918022W	1918222W	1
18"	1118022W	1118222W	1
24"	1218022W	1218222W	1
30"	1318022W	-	2
36"	1418022W	-	2
42"	1818022W	-	2
48"	1518022W	-	2
513mm	1618022W	1618222W	1
1000mm	1718022W	-	2

- Add Option Code 90 to order Sink Hanger Supports.

**End Sink Units**



Description	54" Wide	58" Wide
Full Door Unit	9900017W	9900018W
False Panel Unit	9900021W	9900022W

- Full Door End Sink Unit shown.
- Add Option Code 90 to order Sink Hanger Supports.



Description	54" Wide	58" Wide
Full Door Unit	9900317W	9900318W

- Full Door End Sink Unit shown.
- Add Option Code 90 to order Sink Hanger Supports.

**Corner Sink Units**

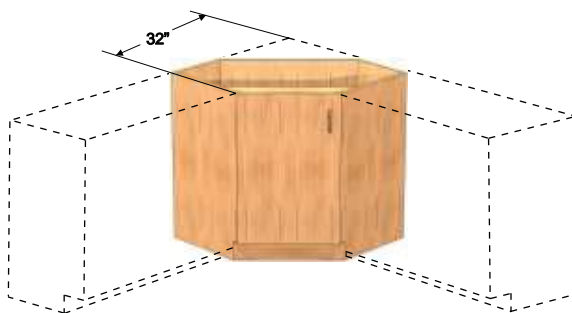

Description	Right Hinged	Left Hinged
Full Door Unit	1017211W	1017511W
False Panel Unit	1017722W	1017622W

- Left Hinge, Corner Sink Unit shown.
- Overall depth of this unit is 26" from the front of the door to the back of the cabinet.
- Add Option Code 90 to order Sink Hanger Supports.

*WOOD CABINETS  
BASE CABINETS - SITTING HEIGHT*

**Sink Units**

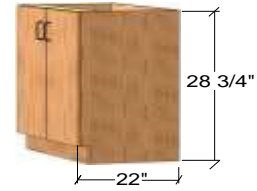

up to 24" wide



30" and wider

Width	Right Hinged	Left Hinged	# of Doors
12"	1023011W	1023211W	1
15"	1923011W	1923211W	1
18"	1123011W	1123211W	1
24"	1223011W	1223211W	1
30"	1323011W	-	2
36"	1423011W	-	2
42"	1823011W	-	2
48"	1523011W	-	2
513mm	1623011W	1623211W	1
1000mm	1723011W	-	2

- Add Option Code 90 to order Sink Hanger Supports.



up to 24" wide



30" and wider

Width	Right Hinged	Left Hinged	# of Doors
12"	1028022W	1028222W	1
15"	1928022W	1928222W	1
18"	1128022W	1128222W	1
24"	1228022W	1228222W	1
30"	1328022W	-	2
36"	1428022W	-	2
42"	1828022W	-	2
48"	1528022W	-	2
513mm	1628022W	1628222W	1
1000mm	1728022W	-	2

- Add Option Code 90 to order Sink Hanger Supports.

**End Sink Units**



Description	54" Wide	58" Wide
Full Door Unit	9900019W	9900020W
False Panel Unit	9900023W	9900024W

- Full Door End Sink Unit shown.
- Add Option Code 90 to order Sink Hanger Supports.



Description	54" Wide	58" Wide
Full Door Unit	9980319W	9980320W

- Full Door End Sink Unit shown.
- Add Option Code 90 to order Sink Hanger Supports.

**Sink Support Kit**



Width	Cabinet Depth	
	18" D	22" D
12"	SSW0012	SSW1012
15"	SSW0015	SSW1015
18"	SSW0018	SSW1018
24"	SSW0024	SSW1024
30"	SSW0030	SSW1030
36"	SSW0036	SSW1036
42"	SSW0042	SSW1042
48"	SSW0048	SSW1048
54"	SSW0054	SSW1054
58"	SSW0058	SSW1058

Description	Cabinet Depth
	26" D
Corner Unit	SSW0000

- Metal frame to support and position an undermount sink.
- Sink Support Kit for Corner Unit not exactly as shown.



*WOOD CASEWORK  
BASE CABINETS - ADA HEIGHT*

**Sink Units**

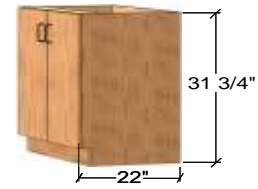

up to 24" wide



30" and wider

Width	Right Hinged	Left Hinged	# of Doors
12"	1083011W	1083211W	1
15"	1983011W	1983211W	1
18"	1183011W	1183211W	1
24"	1283011W	1283211W	1
30"	1383011W	-	2
36"	1483011W	-	2
42"	1883011W	-	2
48"	1583011W	-	2
513mm	1683011W	1683211W	1
1000mm	1783011W	-	2

- Add Option Code 90 to order Sink Hanger Supports.



up to 24" wide



30" and wider

Width	Right Hinged	Left Hinged	# of Doors
12"	1088022W	1088222W	1
15"	1988022W	1988222W	1
18"	1188022W	1188222W	1
24"	1288022W	1288222W	1
30"	1388022W	-	2
36"	1488022W	-	2
42"	1888022W	-	2
48"	1588022W	-	2
513mm	1688022W	1688222W	1
1000mm	1788022W	-	2

- Add Option Code 90 to order Sink Hanger Supports.

**End Sink Units**



Description	54" Wide	58" Wide
Full Door Unit	9980017W	9980018W
False Panel Unit	9980021W	9980022W

- Full Door End Sink Unit shown.
- Add Option Code 90 to order Sink Hanger Supports.

Description	54" Wide	58" Wide
Full Door Unit	9980317W	9980318W

- Full Door End Sink Unit shown.
- Add Option Code 90 to order Sink Hanger Supports.

**Corner Sink Units**

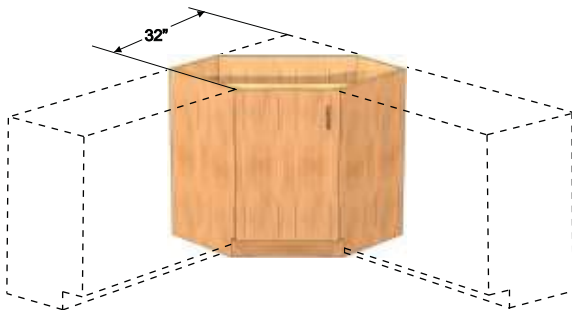

Description	Right Hinged	Left Hinged
Full Door Unit	1087211W	1087511W
False Panel Unit	1087722W	1087622W

- Left Hinge, Corner Sink Unit shown.
- Overall depth of this unit is 26" from the front of the door to the back of the cabinet.
- Add Option Code 90 to order Sink Hanger Supports.

*WOOD CASEWORK  
BASE CABINETS - ADA HEIGHT*

**Pocket Door Sink Units**



Base bottom in down position

Base bottom in knee space position

Width	Item Number
30"	138KS22W
36"	148KS22W
42"	188KS22W
48"	158KS22W
1000mm	178KS22W

- Incorporates pocket doors and fold-up base to convert from sink cabinet design to knee space design.

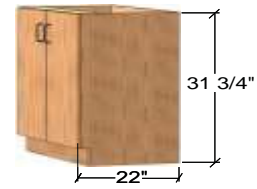

**Corner Sink Units**

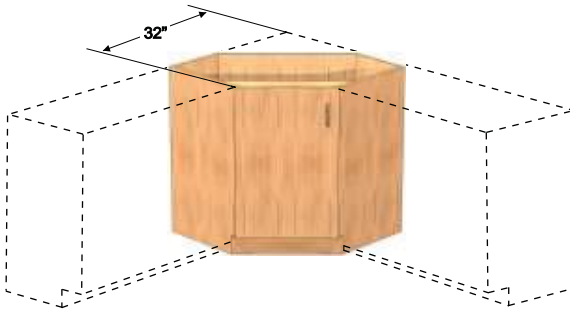

Description	Right Hinged	Left Hinged
Full Door Unit	1087211W	1087511W
False Panel Unit	1087722W	1087622W

- Left Hinge, Corner Sink Unit shown.
- Overall depth of this unit is 26" from the front of the door to the back of the cabinet.
- Add Option Code 90 to order Sink Hanger Supports.

*WOOD CABINETS  
BASE CABINETS - ADA HEIGHT*

**Knee Space Sink Cabinets**

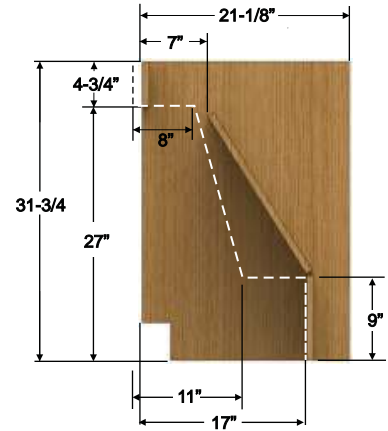
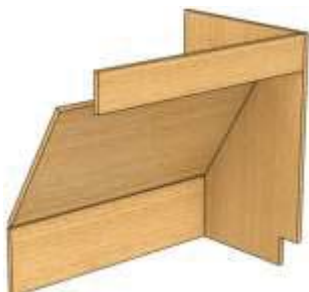
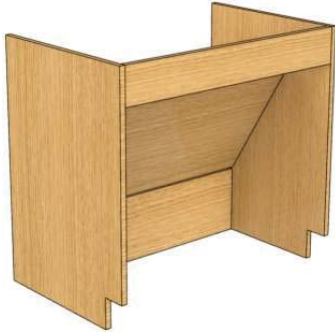

Note: Dotted line represents ADA requirements.

Knee Space Sink Cabinet	
Width	Item Number
30"	13K3011W
33"	13K3311W
36"	14K3011W
42"	18K3011W
48"	15K3011W
1000mm	17K3011W

- Gable Legs are 3/4" wide on this unit.
- Knee Space ships assembled.
- Accommodates a 6" deep sink.
- 30" wide cabinets are not ADA compliant.

Center Panel Only	
Width	Item Number
30"	13KP011W
36"	14KP011W
42"	18KP011W
48"	15KP011W
1000mm	17KP011W

- Knee Space ships unassembled.
- Accommodates a 6" deep sink.

Left Leg With Center Panel	
Width	Item Number
30"	13KL011W
36"	14KL011W
42"	18KL011W
48"	15KL011W
1000mm	17KL011W

- Gable Legs are 3/4" wide on this unit.
- Knee Space ships unassembled.
- Accommodates a 6" deep sink.
- 30" wide cabinets are not ADA compliant.

Right Leg With Center Panel	
Width	Item Number
30"	13KR011W
36"	14KR011W
42"	18KR011W
48"	15KR011W
1000mm	17KR011W

- Gable Legs are 3/4" wide on this unit.
- Knee Space ships unassembled.
- Accommodates a 6" deep sink.
- 30" wide cabinets are not ADA compliant.

*WOOD CASEWORK  
WALL CABINETS*

**Open Units**



Width	Item Number
18"	5170010W
24"	5270010W
30"	5370010W
36"	5470010W
42"	5670010W
48"	5570010W
513mm	5970010W
1000mm	5870010W

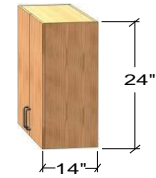

- Actual depth is 7/8" less than nominal.

**Hinged Framed Door Units**



up to 24" wide



30" and wider

Width	Right Hinged	Left Hinged	# of Doors
18"	5170030W	5171030W	1
24"	5270030W	5271030W	1
30"	5370030W	-	2
36"	5470030W	-	2
42"	5670030W	-	2
48"	5570030W	-	2
513mm	5970030W	5971030W	1
1000mm	5870030W	-	2

**Hinged Door Units**



up to 24" wide



30" and wider

Width	Right Hinged	Left Hinged	# of Doors
18"	5170060W	5171060W	1
24"	5270060W	5271060W	1
30"	5370060W	-	2
36"	5470060W	-	2
42"	5670060W	-	2
48"	5570060W	-	2
513mm	5970060W	5971060W	1
1000mm	5870060W	-	2

**Sliding Glass Door Units**



Width	Item Number
30"	5370020W
36"	5470020W
42"	5670020W
48"	5570020W
1000mm	5870020W

*WOOD CASEWORK  
WALL CABINETS*

**Sliding Framed Door Units**

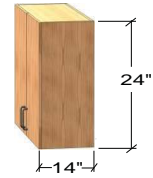

Width	Item Number
30"	5370040W
36"	5470040W
42"	5670040W
48"	5570040W
1000mm	5870040W

**Sliding Door Units**



Width	Item Number
30	5370050W
36	5470050W
42	5670050W
48	5570050W
1000mm	5870050W

*BLIND CORNER WALL CABINETS*

**Hinged Framed Door Units**



Width	Door On Right	Door On Left
30"	5370330W	5370430W
36"	5470330W	5470430W
42"	5670330W	5670430W
48"	5570330W	5570430W
1000mm	5870330W	5870430W

- Right Door Blind Corner Framed Unit shown.
- Left Door Blind Corner Framed Units are reverse of what is shown.
- Blind portion of cabinet is 14" wide.

**Hinged Door Units**



Width	Door On Right	Door On Left
30"	5370360W	5370460W
36"	5470360W	5470460W
42"	5670360W	5670460W
48"	5570360W	5570460W
1000mm	5870360W	5870460W

- Right Door Blind Corner Unit shown.
- Left Door Blind Corner Units are reverse of what is shown.
- Blind portion of cabinet is 14" wide.

*WOOD CASEWORK  
WALL CABINETS*

**Open Units**



Width	Item Number
18"	5110010W
24"	5210010W
30"	5310010W
36"	5410010W
42"	5610010W
48"	5510010W
513mm	5910010W
1000mm	5810010W

• Actual depth is 7/8" less than nominal.



**Hinged Framed Door Units**



up to 24" wide



30" and wider

Width	Right Hinged	Left Hinged	# of Doors
18"	5110030W	5111030W	1
24"	5210030W	5211030W	1
30"	5310030W	-	2
36"	5410030W	-	2
42"	5610030W	-	2
48"	5510030W	-	2
513mm	5910030W	5911030W	1
1000mm	5810030W	-	2

**Hinged Door Units**



up to 24" wide



30" and wider

Width	Right Hinged	Left Hinged	# of Doors
18"	5110060W	5111060W	1
24"	5210060W	5211060W	1
30"	5310060W	-	2
36"	5410060W	-	2
42"	5610060W	-	2
48"	5510060W	-	2
513mm	5910060W	5911060W	1
1000mm	5810060W	-	2

**Sliding Glass Door Units**



Width	Item Number
30"	5310020W
36"	5410020W
42"	5610020W
48"	5510020W
1000mm	5810020W



*WALL CABINETS*

**Sliding Framed Door Units**



Width	Item Number
30"	5310040W
36"	5410040W
42"	5610040W
48"	5510040W
1000mm	5810040W

**Sliding Door Units**



Width	Item Number
30"	5310050W
36"	5410050W
42"	5610050W
48"	5510050W
1000mm	5810050W

*BLIND CORNER WALL CABINETS*

**Hinged Framed Door Units**



Width	Door On Right	Door On Left
30"	5310330W	5310430W
36"	5410330W	5410430W
42"	5610330W	5610430W
48"	5510330W	5510430W
1000mm	5810330W	5810430W

- Right Door Blind Corner Framed Unit shown.
- Left Door Blind Corner Framed Units are reverse of what is shown.
- Blind portion of cabinet is 14" wide.

**Hinged Door Units**

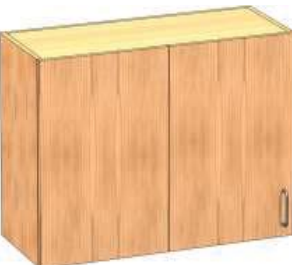

Width	Door On Right	Door On Left
30"	5310360W	5310460W
36"	5410360W	5410460W
42"	5610360W	5610460W
48"	5510360W	5510460W
1000mm	5810360W	5810460W

- Right Door Blind Corner Unit shown.
- Left Door Blind Corner Units are reverse of what is shown.
- Blind portion of cabinet is 14" wide.



*WOOD CASEWORK  
WALL CABINETS*

**Open Units**



Width	Item Number
18"	5120010W
24"	5220010W
30"	5320010W
36"	5420010W
42"	5620010W
48"	5520010W
513mm	5920010W
1000mm	5820010W

• Actual depth is 7/8" less than nominal.

**Hinged Framed Door Units**



up to 24" wide



30" and wider

Width	Right Hinged	Left Hinged	# of Doors
18"	5120030W	5121030W	1
24"	5220030W	5221030W	1
30"	5320030W	-	2
36"	5420030W	-	2
42"	5620030W	-	2
48"	5520030W	-	2
513mm	5920030W	5921030W	1
1000mm	5820030W	-	2

**Hinged Door Units**



up to 24" wide



30" and wider

Width	Right Hinged	Left Hinged	# of Doors
18"	5120060W	5121060W	1
24"	5220060W	5221060W	1
30"	5320060W	-	2
36"	5420060W	-	2
42"	5620060W	-	2
48"	5520060W	-	2
513mm	5920060W	5921060W	1
1000mm	5820060W	-	2

**Sliding Glass Door Units**



Width	Item Number
30"	5320020W
36"	5420020W
42"	5620020W
48"	5520020W
1000mm	5820020W

*WOOD CASEWORK  
WALL CABINETS*

**Sliding Framed Door Units**



Width	Item Number
30"	5320040W
36"	5420040W
42"	5620040W
48"	5520040W
1000mm	5820040W

**Sliding Door Units**



Width	Item Number
30"	5320050W
36"	5420050W
42"	5620050W
48"	5520050W
1000mm	5820050W

*BLIND CORNER WALL CABINETS*

**Hinged Framed Door Units**



Width	Door On Right	Door On Left
30"	5320330W	5320430W
36"	5420330W	5420430W
42"	5620330W	5620430W
48"	5520330W	5520430W
1000mm	5820330W	5820430W

- Right Door Blind Corner Framed Unit shown.
- Left Door Blind Corner Framed Units are reverse of what is shown.
- Blind portion of cabinet is 14" wide.

**Hinged Door Units**



Width	Door On Right	Door On Left
30"	5320360W	5320460W
36"	5420360W	5420460W
42"	5620360W	5620460W
48"	5520360W	5520460W
1000mm	5820360W	5820460W

- Right Door Blind Corner Unit shown.
- Left Door Blind Corner Units are reverse of what is shown.
- Blind portion of cabinet is 14" wide.

*WOOD CASEWORK  
WALL CABINETS*

**Open Units**



Width	Item Number
18"	5130010W
24"	5230010W
30"	5330010W
36"	5430010W
42"	5630010W
48"	5530010W
513mm	5930010W
1000mm	5830010W

- Actual depth is 7/8" less than nominal.

**Hinged Framed Door Units**



up to 24" wide



30" and wider

Width	Right Hinged	Left Hinged	# of Doors
18"	5130030W	5131030W	1
24"	5230030W	5231030W	1
30"	5330030W	-	2
36"	5430030W	-	2
42"	5630030W	-	2
48"	5530030W	-	2
513mm	5930030W	5931030W	1
1000mm	5830030W	-	2

**Hinged Door Units**



up to 24" wide



30" and wider

Width	Right Hinged	Left Hinged	# of Doors
18"	5130060W	5131060W	1
24"	5230060W	5231060W	1
30"	5330060W	-	2
36"	5430060W	-	2
42"	5630060W	-	2
48"	5530060W	-	2
513mm	5930060W	5931060W	1
1000mm	5830060W	-	2

**Sliding Glass Door Units**



Width	Item Number
30"	5330020W
36"	5430020W
42"	5630020W
48"	5530020W
1000mm	5830020W

*WOOD CASEWORK  
WALL CABINETS*

**Sliding Framed Door Units**



Width	Item Number
30"	5330040W
36"	5430040W
42"	5630040W
48"	5530040W
1000mm	5830040W

**Sliding Door Units**



Width	Item Number
30"	5330050W
36"	5430050W
42"	5630050W
48"	5530050W
1000mm	5830050W

*BLIND CORNER WALL CABINETS*

**Hinged Framed Door Units**



Width	Door On Right	Door On Left
30"	5330330W	5330430W
36"	5430330W	5430430W
42"	5630330W	5630430W
48"	5530330W	5530430W
1000mm	5830330W	5830430W

- Right Door Blind Corner Framed Unit shown.
- Left Door Blind Corner Framed Units are reverse of what is shown.
- Blind portion of cabinet is 14" wide.

**Hinged Door Units**

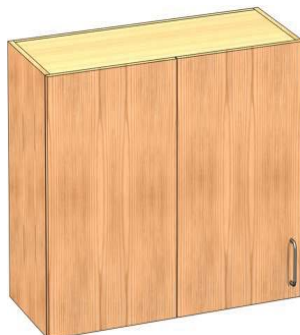

Width	Door On Right	Door On Left
30"	5330360W	5330460W
36"	5430360W	5430460W
42"	5630360W	5630460W
48"	5530360W	5530460W
1000mm	5830360W	5830460W

- Right Door Blind Corner Unit shown.
- Left Door Blind Corner Units are reverse of what is shown.
- Blind portion of cabinet is 14" wide.



*WOOD CASEWORK  
WALL CABINETS*

**Open Units**

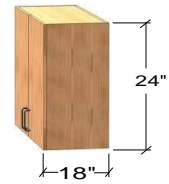

Width	Item Number
18"	5180010W
24"	5280010W
30"	5380010W
36"	5480010W
42"	5680010W
48"	5580010W
513mm	5980010W
1000mm	5880010W

- Actual depth is 7/8" less than nominal.

**Hinged Framed Door Units**



up to 24" wide



30" and wider

Width	Right Hinged	Left Hinged	# of Doors
18"	5180030W	5181030W	1
24"	5280030W	5281030W	1
30"	5380030W	-	2
36"	5480030W	-	2
42"	5680030W	-	2
48"	5580030W	-	2
513mm	5980030W	5981030W	1
1000mm	5880030W	-	2

**Hinged Door Units**



up to 24" wide



30" and wider

Width	Right Hinged	Left Hinged	# of Doors
18"	5180060W	5181060W	1
24"	5280060W	5281060W	1
30"	5380060W	-	2
36"	5480060W	-	2
42"	5680060W	-	2
48"	5580060W	-	2
513mm	5980060W	5981060W	1
1000mm	5880060W	-	2

**Sliding Glass Door Units**



Width	Item Number
30"	5380020W
36"	5480020W
42"	5680020W
48"	5580020W
1000mm	5880020W

*WOOD CASEWORK  
WALL CABINETS*

**Sliding Framed Door Units**

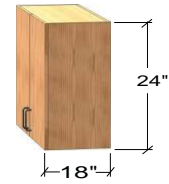

Width	Item Number
30"	5380040W
36"	5480040W
42"	5680040W
48"	5580040W
1000mm	5880040W

**Sliding Door Units**



Width	Item Number
30"	5380050W
36"	5480050W
42"	5680050W
48"	5580050W
1000mm	5880050W

*BLIND CORNER WALL CABINETS*

**Hinged Framed Door Units**



Width	Door On Right	Door On Left
30"	5380330W	5380430W
36"	5480330W	5480430W
42"	5680330W	5680430W
48"	5580330W	5580430W
1000mm	5880330W	5880430W

- Right Door Blind Corner Framed Unit shown.
- Left Door Blind Corner Framed Units are reverse of what is shown.
- Blind portion of cabinet is 18" wide.

**Hinged Door Units**



Width	Door On Right	Door On Left
30"	5380360W	5380460W
36"	5480360W	5480460W
42"	5680360W	5680460W
48"	5580360W	5580460W
1000mm	5880360W	5880460W

- Right Door Blind Corner Unit shown.
- Left Door Blind Corner Units are reverse of what is shown.
- Blind portion of cabinet is 18" wide.



*WOOD CASEWORK  
WALL CABINETS*

**Open Units**



Width	Item Number
18"	5140010W
24"	5240010W
30"	5340010W
36"	5440010W
42"	5640010W
48"	5540010W
513mm	5940010W
1000mm	5840010W

- Actual depth is 7/8" less than nominal.

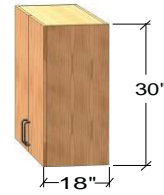

**Hinged Framed Door Units**



up to 24" wide



30" and wider

Width	Right Hinged	Left Hinged	# of Doors
18"	5140030W	5141030W	1
24"	5240030W	5241030W	1
30"	5340030W	-	2
36"	5440030W	-	2
42"	5640030W	-	2
48"	5540030W	-	2
513mm	5940030W	5941030W	1
1000mm	5840030W	-	2

**Hinged Door Units**



up to 24" wide



30" and wider

Width	Right Hinged	Left Hinged	# of Doors
18"	5140060W	5141060W	1
24"	5240060W	5241060W	1
30"	5340060W	-	2
36"	5440060W	-	2
42"	5640060W	-	2
48"	5540060W	-	2
513mm	5940060W	5941060W	1
1000mm	5840060W	-	2

**Sliding Glass Door Units**



Width	Item Number
30"	5340020W
36"	5440020W
42"	5640020W
48"	5540020W
1000mm	5840020W



*WOOD CASEWORK  
WALL CABINETS*

**Sliding Framed Door Units**

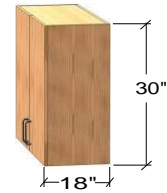

Width	Item Number
30"	5340040W
36"	5440040W
42"	5640040W
48"	5540040W
1000mm	5840040W

**Sliding Door Units**



Width	Item Number
30"	5340050W
36"	5440050W
42"	5640050W
48"	5540050W
1000mm	5840050W

*BLIND CORNER WALL CABINETS*

**Hinged Framed Door Units**



Width	Door On Right	Door On Left
30"	5340330W	5340430W
36"	5440330W	5440430W
42"	5640330W	5640430W
48"	5540330W	5540430W
1000mm	5840330W	5840430W

- Right Door Blind Corner Framed Unit shown.
- Left Door Blind Corner Framed Units are reverse of what is shown.
- Blind portion of cabinet is 18" wide.

**Hinged Door Units**



Width	Door On Right	Door On Left
30"	5340360W	5340460W
36"	5440360W	5440460W
42"	5640360W	5640460W
48"	5540360W	5540460W
1000mm	5840360W	5840460W

- Right Door Blind Corner Unit shown.
- Left Door Blind Corner Units are reverse of what is shown.
- Blind portion of cabinet is 18" wide.

*WOOD CASEWORK  
WALL CABINETS*

**Open Units**

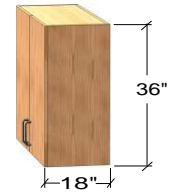

Width	Item Number
18"	5150010W
24"	5250010W
30"	5350010W
36"	5450010W
42"	5650010W
48"	5550010W
513mm	5950010W
1000mm	5850010W

• Actual depth is 7/8" less than nominal.

**Hinged Framed Door Units**



up to 24" wide



30" and wider

Width	Right Hinged	Left Hinged	# of Doors
18"	5150030W	5151030W	1
24"	5250030W	5251030W	1
30"	5350030W	-	2
36"	5450030W	-	2
42"	5650030W	-	2
48"	5550030W	-	2
513mm	5950030W	5951030W	1
1000mm	5850030W	-	2

**Hinged Door Units**



up to 24" wide

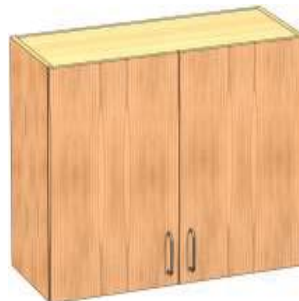

30" and wider

Width	Right Hinged	Left Hinged	# of Doors
18"	5150060W	5151060W	1
24"	5250060W	5251060W	1
30"	5350060W	-	2
36"	5450060W	-	2
42"	5650060W	-	2
48"	5550060W	-	2
513mm	5950060W	5951060W	1
1000mm	5850060W	-	2

**Sliding Glass Door Units**



Width	Item Number
30"	5350020W
36"	5450020W
42"	5650020W
48"	5550020W
1000mm	5850020W

*WOOD CASEWORK  
WALL CABINETS*

**Sliding Framed Door Units**



Width	Item Number
30"	5350040W
36"	5450040W
42"	5650040W
48"	5550040W
1000mm	5850040W

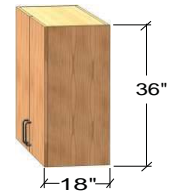

**Sliding Door Units**



Width	Item Number
30"	5350050W
36"	5450050W
42"	5650050W
48"	5550050W
1000mm	5850050W

*BLIND CORNER WALL CABINETS*

**Hinged Framed Door Units**



Width	Door On Right	Door On Left
30"	5350330W	5350430W
36"	5450330W	5450430W
42"	5650330W	5650430W
48"	5550330W	5550430W
1000mm	5850330W	5850430W

- Right Door Blind Corner Framed Unit shown.
- Left Door Blind Corner Framed Units are reverse of what is shown.
- Blind portion of cabinet is 18" wide.

**Hinged Door Units**



Width	Door On Right	Door On Left
30"	5350360W	5350460W
36"	5450360W	5450460W
42"	5650360W	5650460W
48"	5550360W	5550460W
1000mm	5850360W	5850460W

- Right Door Blind Corner Unit shown.
- Left Door Blind Corner Units are reverse of what is shown.
- Blind portion of cabinet is 18" wide.

*WOOD CASEWORK  
WALL CABINETS*

**Open Units**



Width	Item Number
18"	5160010W
24"	5260010W
30"	5360010W
36"	5460010W
42"	5660010W
48"	5560010W
513mm	5960010W
1000mm	5860010W



- Actual depth is 7/8" less than nominal.

**Hinged Framed Door Units**



up to 24" wide



30" and wider

Width	Right Hinged	Left Hinged	# of Doors
18"	5160030W	5161030W	1
24"	5260030W	5261030W	1
30"	5360030W	-	2
36"	5460030W	-	2
42"	5660030W	-	2
48"	5560030W	-	2
513mm	5960030W	5961030W	1
1000mm	5860030W	-	2

**Hinged Door Units**



up to 24" wide



30" and wider

Width	Right Hinged	Left Hinged	# of Doors
18"	5160060W	5161060W	1
24"	5260060W	5261060W	1
30"	5360060W	-	2
36"	5460060W	-	2
42"	5660060W	-	2
48"	5560060W	-	2
513mm	5960060W	5961060W	1
1000mm	5860060W	-	2

**Sliding Glass Door Units**



Width	Item Number
30"	5360020W
36"	5460020W
42"	5660020W
48"	5560020W
1000mm	5860020W

**Sliding Framed Door Units**



Width	Item Number
30"	5360040W
36"	5460040W
42"	5660040W
48"	5560040W
1000mm	5860040W



*WOOD CASEWORK  
WALL CABINETS*

**Sliding Door Units**



Width	Item Number
30"	5360050W
36"	5460050W
42"	5660050W
48"	5560050W
1000mm	5860050W



*BLIND CORNER WALL CABINETS*

**Hinged Framed Door Units**



Width	Door On Right	Door On Left
30"	5360330W	5360430W
36"	5460330W	5460430W
42"	5660330W	5660430W
48"	5560330W	5560430W
1000mm	5860330W	5860430W

- Right Door Blind Corner Framed Unit shown.
- Left Door Blind Corner Framed Units are reverse of what is shown.
- Blind portion of cabinet is 18" wide.

**Hinged Door Units**



Width	Door On Right	Door On Left
30"	5360360W	5360460W
36"	5460360W	5460460W
42"	5660360W	5660460W
48"	5560360W	5560460W
1000mm	5860360W	5860460W

- Right Door Blind Corner Unit shown.
- Left Door Blind Corner Units are reverse of what is shown.
- Blind portion of cabinet is 18" wide.

**Hinged Framed Door Units**

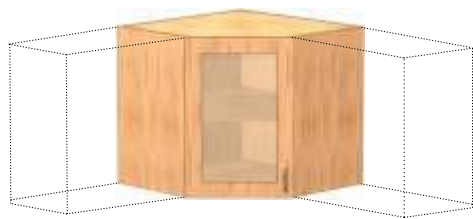

Height	Right Hinged	Left Hinged	Depth
24"	5070030W	5071030W	14"
30"	5010030W	5011030W	14"
36"	5020030W	5021030W	14"
48"	5030030W	5031030W	14"
24"	5080030W	5081030W	18"
30"	5040030W	5041030W	18"
36"	5050030W	5051030W	18"
48"	5060030W	5061030W	18"

- These units include integral rear upper and lower corner filler panels.

**Hinged Door Units**

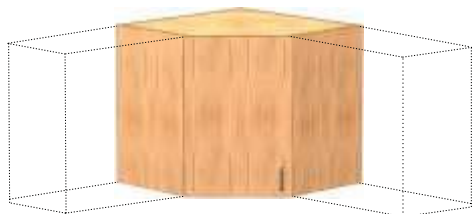

Height	Right Hinged	Left Hinged	Depth
24"	5070060W	5071060W	14"
30"	5010060W	5011060W	14"
36"	5020060W	5021060W	14"
48"	5030060W	5031060W	14"
24"	5080060W	5081060W	18"
30"	5040060W	5041060W	18"
36"	5050060W	5051060W	18"
48"	5060060W	5061060W	18"

- These units include integral rear upper and lower corner filler panels.

*WOOD CASEWORK  
WALL CABINETS*

**Sigma Flex™ Wall Cabinet Hanger Rails**

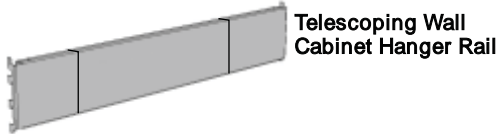
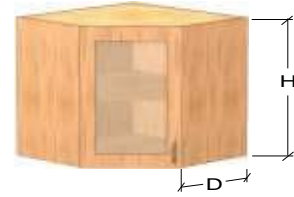

Telescoping Wall Cabinet Hanger Rail

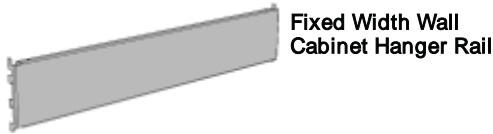

Fixed Width Wall Cabinet Hanger Rail

Width	Telescoping Rail	Fixed Width Rail
24"	TWR0024	FWR0024
30"	TWR0030	FWR0030
36"	TWR0036	FWR0036
42"	TWR0042	FWR0042
48"	TWR0048	FWR0048
54"	TWR0054	FWR0054
60"	TWR0060	FWR0060
72"	TWR0072	FWR0072

- Sigma Flex™ Wall Cabinet Hanger Rails are required to hang above-counter storage cabinets on to Sigma Flex™ systems.
- Order rails to match width of support structure frame (Telescoping Rails are not suitable for cabinets smaller than 24" wide).
- Telescoping Rail is adjustable up to 5".
- Wall cabinets must be ordered with "J" Mounting Rails to suspend from Sigma Flex™ and Sigma Cart™ products.

**Sigma Frame™ Wall Cabinet Hanger Rails**

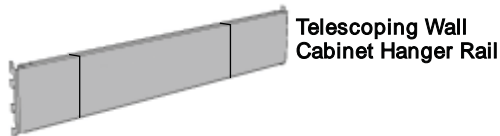

Telescoping Wall Cabinet Hanger Rail

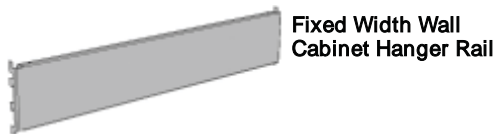

Fixed Width Wall Cabinet Hanger Rail

Width	Telescoping Rail	Fixed Width Rail
24"	AWR0024	SWR0024
30"	AWR0030	SWR0030
36"	AWR0036	SWR0036
42"	AWR0042	SWR0042
48"	AWR0048	SWR0048
54"	AWR0054	SWR0054
60"	AWR0060	SWR0060
72"	AWR0072	SWR0072

- Sigma Frame™ Wall Cabinet Hanger Rails are required to hang above-counter storage cabinets on to Sigma Frame™ systems.
- Order rails to match width of support structure frame (Telescoping Rails are not suitable for cabinets smaller than 24" wide).
- Telescoping Rail is adjustable up to 5".
- Wall cabinets must be ordered with "J" Mounting Rails to suspend from Sigma Frame™ products.

**Wall Cabinet "J" Mounting Rails**



Width	Item Number
24"	JR00024
30"	JR00030
36"	JR00036
42"	JR00042
48"	JR00048
54"	JR00054
60"	JR00060
66"	JR00066
72"	JR00072

- A "J" Mounting Rail is required to hang wood above-counter storage cabinets on to Sigma Flex™ and Sigma Frame™ products.
- Order "J" rails to match width of support structure frame and Wall Cabinet Hanger Rail.
- "J" Rail ships loose.



*WOOD CASEWORK  
FLOOR CABINETS*

**Open Units**



Width	Item Number
18"	6110010W
24"	6210010W
30"	6310010W
36"	6410010W
42"	6610010W
48"	6510010W
513mm	6910010W
1000mm	6810010W

- Actual depth is 7/8" less than nominal.

**Hinged Framed Door Units**



up to 24" wide



30" and wider

Width	Right Hinged	Left Hinged	# of Doors
18"	6110030W	6110230W	2
24"	6210030W	6210230W	2
30"	6310030W	-	4
36"	6410030W	-	4
42"	6610030W	-	4
48"	6510030W	-	4
513mm	6910030W	6910230W	2
1000mm	6810030W	-	4

- Add Option Code 80 to order full height doors.
- Full height door units have a fixed center shelf.

**Hinged Door Units**



up to 24" wide



30" and wider

Width	Right Hinged	Left Hinged	# of Doors
18"	6110060W	6110260W	2
24"	6210060W	6210260W	2
30"	6310060W	-	4
36"	6410060W	-	4
42"	6610060W	-	4
48"	6510060W	-	4
513mm	6910060W	6910260W	2
1000mm	6810060W	-	4

- Add Option Code 80 to order full height doors.
- Full height door units have a fixed center shelf.



*WOOD CABINETS  
FLOOR CABINETS*

**Sliding Glass Door Units**

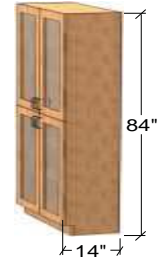

Width	Item Number
30"	6310020W
36"	6410020W
42"	6610020W
48"	6510020W
1000mm	6810020W

- Add Option Code 80 to order full height doors.
- Full height door units have a fixed center shelf.

**Sliding Framed Door Units**



Width	Item Number
30"	6310040W
36"	6410040W
42"	6610040W
48"	6510040W
1000mm	6810040W

- Add Option Code 80 to order full height doors.
- Full height door units have a fixed center shelf.

**Sliding Door Units**



Width	Item Number
30"	6310050W
36"	6410050W
42"	6610050W
48"	6510050W
1000mm	6810050W

- Add Option Code 80 to order full height doors.
- Full height door units have a fixed center shelf.

*WOOD CASEWORK  
FLOOR CABINETS*

**Open Units**



Width	Item Number
18"	6120010W
24"	6220010W
30"	6320010W
36"	6420010W
42"	6620010W
48"	6520010W
513mm	6920010W
1000mm	6820010W

- Actual depth is 7/8" less than nominal.

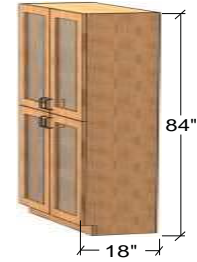

**Hinged Framed Door Units**



up to 24" wide



30" and wider

Width	Right Hinged	Left Hinged	# of Doors
18"	6120030W	6120230W	2
24"	6220030W	6220230W	2
30"	6320030W	-	4
36"	6420030W	-	4
42"	6620030W	-	4
48"	6520030W	-	4
513mm	6920030W	6920230W	2
1000mm	6820030W	-	4

- Add Option Code 80 to order full height doors.
- Full height door units have a fixed center shelf.

**Hinged Door Units**



up to 24" wide



30" and wider

Width	Right Hinged	Left Hinged	# of Doors
18"	6120060W	6120260W	2
24"	6220060W	6220260W	2
30"	6320060W	-	4
36"	6420060W	-	4
42"	6620060W	-	4
48"	6520060W	-	4
513mm	6920060W	6920260W	2
1000mm	6820060W	-	4

- Add Option Code 80 to order full height doors.
- Full height door units have a fixed center shelf.

*WOOD CABINETS  
FLOOR CABINETS*

**Sliding Glass Door Units**

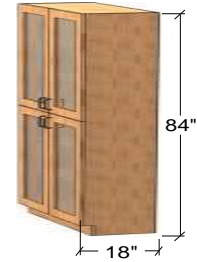

Width	Item Number
30"	6320020W
36"	6420020W
42"	6620020W
48"	6520020W
1000mm	6820020W

- Add Option Code 80 to order full height doors.
- Full height door units have a fixed center shelf.

**Sliding Framed Door Units**



Width	Item Number
30"	6320040W
36"	6420040W
42"	6620040W
48"	6520040W
1000mm	6820040W

- Add Option Code 80 to order full height doors.
- Full height door units have a fixed center shelf.

**Sliding Door Units**



Width	Item Number
30"	6320050W
36"	6420050W
42"	6620050W
48"	6520050W
1000mm	6820050W

- Add Option Code 80 to order full height doors.
- Full height door units have a fixed center shelf.

*WOOD CASEWORK  
FLOOR CABINETS*

**Open Units**



Width	Item Number
18"	6130010W
24"	6230010W
30"	6330010W
36"	6430010W
42"	6630010W
48"	6530010W
513mm	6930010W
1000mm	6830010W

• Actual depth is 7/8" less than nominal.

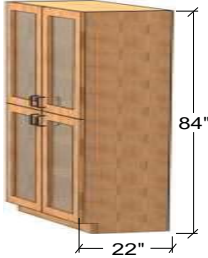

**Hinged Framed Door Units**



up to 24" wide



30" and wider

Width	Right Hinged	Left Hinged	# of Doors
18"	6130030W	6130230W	2
24"	6230030W	6230230W	2
30"	6330030W	-	4
36"	6430030W	-	4
42"	6630030W	-	4
48"	6530030W	-	4
513mm	6930030W	6930230W	2
1000mm	6830030W	-	4

- Add Option Code 80 to order full height doors.
- Full height door units have a fixed center shelf.

**Hinged Door Units**



up to 24" wide



30" and wider

Width	Right Hinged	Left Hinged	# of Doors
18"	6130060W	6130260W	2
24"	6230060W	6230260W	2
30"	6330060W	-	4
36"	6430060W	-	4
42"	6630060W	-	4
48"	6530060W	-	4
513mm	6930060W	6930260W	2
1000mm	6830060W	-	4

- Add Option Code 80 to order full height doors.
- Full height door units have a fixed center shelf.

*WOOD CABINETS  
FLOOR CABINETS*

**Sliding Glass Door Units**

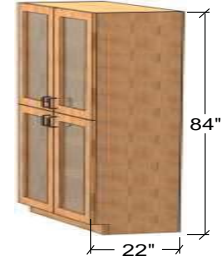

Width	Item Number
30"	6330020W
36"	6430020W
42"	6630020W
48"	6530020W
1000mm	6830020W

- Add Option Code 80 to order full height doors.
- Full height door units have a fixed center shelf.

**Sliding Framed Door Units**



Width	Item Number
30"	6330040W
36"	6430040W
42"	6630040W
48"	6530040W
1000mm	6830040W

- Add Option Code 80 to order full height doors.
- Full height door units have a fixed center shelf.

**Sliding Door Units**



Width	Item Number
30"	6330050W
36"	6430050W
42"	6630050W
48"	6530050W
1000mm	6830050W

- Add Option Code 80 to order full height doors.
- Full height door units have a fixed center shelf.



*WOOD CASEWORK  
SPECIALTY FLOOR CABINETS*

**Wardrobe Units**



up to 24" wide

30" and wider

Width	Right Hinged	Left Hinged	# of Doors
15"	6A35060W	6A35260W	1
18"	6135060W	6135260W	1
24"	6235060W	6235260W	1
30"	6335060W	-	2
36"	6435060W	-	2
42"	6635060W	-	2
48"	6535060W	-	2

- Wardrobe Units have solid hinged double doors and include one fixed shelf and a clothes rod.
- Units must have a minimum depth of 22" to hold hangers.
- Mirror is not included.



Width	Item Number
30"	6335660W
36"	6435660W
42"	6635660W
48"	6535660W

- Wardrobe Units have solid hinged double doors and include one fixed shelf with attached clothes rod on the left side with one fixed shelf and four adjustable shelves on the right side.
- Units must have a minimum depth of 22" to hold hangers.
- Mirror is not included.



Width	Item Number
30"	6335760W
36"	6435760W
42"	6635760W
48"	6535760W

- Wardrobe Units have solid hinged double doors and include one fixed shelf with attached clothes rod on the right side one fixed shelf and four adjustable shelves on the left side.
- Units must have a minimum depth of 22" to hold hangers.
- Mirror is not included.

*WOOD CABINETS  
SPECIALTY FLOOR CABINETS*

**Instrument Storage Units**



up to 24" wide



30" and wider

Width	Right Hinged	Left Hinged	# of Doors
18"	61200A0W	61202A0W	2
24"	62200A0W	62202A0W	2
30"	63200A0W	-	4
36"	64200A0W	-	4
42"	66200A0W	-	4
48"	65200A0W	-	4
513mm	69200A0W	69202A0W	2
1000mm	68200A0W	-	4

- The upper section on the Instrument Storage Units has hinged framed glass doors with three adjustable shelves inside.
- The lower section is 34-3/4" high, with hinged solid doors and one adjustable shelf inside.



Width	Item Number
30"	63200B0W
36"	64200B0W
42"	66200B0W
48"	65200B0W
1000mm	68200B0W

- The upper section on the Instrument Storage Units has sliding framed glass doors with three adjustable shelves inside.
- The lower section is 34-3/4" high, with hinged solid doors, one adjustable shelf inside and two pull-out boards.



Width	Item Number
30"	63200C0W
36"	64200C0W
42"	66200C0W
48"	65200C0W
1000mm	68200C0W

- The upper section on the Instrument Storage Units has sliding framed glass doors with three adjustable shelves inside.
- The lower section is 34-3/4" high, with sliding solid doors, one adjustable shelf inside and two pull-out boards.



*WOOD CASEWORK  
SPECIALTY FLOOR CABINETS*

**Instrument Storage Units**



**24" wide**

Width	Right Hinged	Left Hinged
24"	6227030W	6227230W

- The 24" wide Instrument Storage Units have a hinged framed glass door with 15 compartments.
- Unit comes with four adjustable shelves.



**36" wide**

Width	Item Number
36"	6427030W

- The 36" wide Instrument Storage Unit has hinged framed glass double doors with 20 compartments.
- Unit comes with four adjustable shelves.



**48" wide**

Width	Item Number
48"	6527030W

- The 48" wide Instrument Storage Unit has hinged framed glass double doors with 30 compartments.
- Unit comes with four adjustable shelves.

*WOOD CABINETS  
SPECIALTY FLOOR CABINETS*

**Tote Tray Storage Units**



Width	Item Number
48"	6530061W

- Holds 64 totes at 19" deep by 10-1/2" wide by 3-1/2" high.
- Fixed middle shelf.
- Add Option Code 80 to order full height doors.
- Full height door units have a fixed center shelf.
- Totes not included.



Item Number
PTT0001

- One piece tan polystyrene tote.
- 19" deep by 10-1/2" wide by 3-1/2" high.
- Tote comes with label holder on front.



Width	Item Number
48"	6530062W

- Holds 48 totes at 19" deep by 13-3/4" wide by 4-3/8" high.
- Fixed middle shelf.
- Add Option Code 80 to order full height doors.
- Full height door units have a fixed center shelf.
- Totes not included.



Item Number
PTT0002

- One piece tan polystyrene tote.
- 19" deep by 13-3/4" wide by 4-3/8" high.
- Tote comes with label holder on front.

*WOOD CASEWORK  
SPECIALTY CABINETS - STANDING HEIGHT*

**Acid Storage Units (22" Deep)**

See page L9 for vent hole locations.

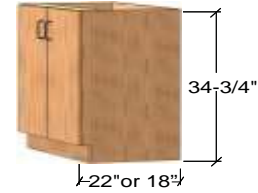

up to 24" wide



30" and wider

Width	Right Hinged	Left Hinged	# of Doors
15"	1911011W	1911211W	1
18"	1111011W	1111211W	1
24"	1211011W	1211211W	1
30"	1311011W	-	2
36"	1411011W	-	2
42"	1811011W	-	2
48"	1511011W	-	2

- Lined with a chemically resistant molded liner and has one black phenolic shelf.
- Add Option Code VK to order a Corrugated Polyolefin Vent Kit.
- Add Option Code 82 to change liner to a FRP liner.



up to 24" wide



30" and wider

Width	Right Hinged	Left Hinged	# of Doors
15"	1916022W	1916222W	1
18"	1116022W	1116222W	1
24"	1216022W	1216222W	1
30"	1316022W	-	2
36"	1416022W	-	2
42"	1816022W	-	2
48"	1516022W	-	2
513mm	1616022W	1616222W	1
1000mm	1716022W	-	2

- Lined with a chemically resistant molded liner and has one black phenolic shelf.
- False panels are 7-1/2" high.
- Add Option Code VK to order a Corrugated Polyolefin Vent Kit.
- Add Option Code 82 to change liner to a FRP liner.

**Acid Storage Units (18" Deep)**



up to 24" wide



30" and wider

Width	Right Hinged	Left Hinged	# of Doors
15"	1931011W	1931211W	1
18"	1131011W	1131211W	1
24"	1231011W	1231211W	1
30"	1331011W	-	2
36"	1431011W	-	2
42"	1831011W	-	2
48"	1531011W	-	2

- Lined with a chemically resistant molded liner and has one black phenolic shelf.
- Add Option Code VK to order a Corrugated Polyolefin Vent Kit.
- Add Option Code 82 to change liner to a FRP liner.



up to 24" wide



30" and wider

Width	Right Hinged	Left Hinged	# of Doors
15"	1936022W	1936222W	1
18"	1136022W	1136222W	1
24"	1236022W	1236222W	1
30"	1336022W	-	2
36"	1436022W	-	2
42"	1836022W	-	2
48"	1536022W	-	2
513mm	1636022W	1636222W	1
1000mm	1736022W	-	2

- Lined with a chemically resistant molded liner and has one black phenolic shelf.
- False panels are 7-1/2" high.
- Add Option Code VK to order a Corrugated Polyolefin Vent Kit.
- Add Option Code 82 to change liner to a FRP liner.

*WOOD CASEWORK  
SPECIALTY CABINETS - SITTING HEIGHT*

**Acid Storage Units (22" Deep)**

See page L9 for vent hole locations.

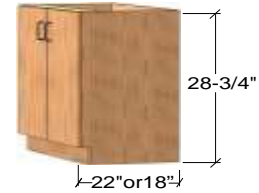

up to 24" wide



30" and wider



up to 24" wide



30" and wider

Width	Right Hinged	Left Hinged	# of Doors
15"	1921011W	1921211W	1
18"	1121011W	1121211W	1
24"	1221011W	1221211W	1
30"	1321011W	-	2
36"	1421011W	-	2
42"	1821011W	-	2
48"	1521011W	-	2
513mm	1621011W	1621211W	1
1000mm	1721011W	-	2

- Lined with a chemically resistant molded liner and has one black phenolic shelf.
- Add Option Code VK to order a Corrugated Polyolefin Vent Kit.

Width	Right Hinged	Left Hinged	# of Doors
15"	1926022W	1926222W	1
18"	1126022W	1126222W	1
24"	1226022W	1226222W	1
30"	1326022W	-	2
36"	1426022W	-	2
42"	1826022W	-	2
48"	1526022W	-	2
513mm	1626022W	1626222W	1
1000mm	1726022W	-	2

- Lined with a chemically resistant molded liner and has one black phenolic shelf.
- False panels are 7-1/2" high.
- Add Option Code VK to order a Corrugated Polyolefin Vent Kit.

**Acid Storage Units (18" Deep)**



up to 24" wide



30" and wider



up to 24" wide



30" and wider

Width	Right Hinged	Left Hinged	# of Doors
15"	1941011W	1941211W	1
18"	1141011W	1141211W	1
24"	1241011W	1241211W	1
30"	1341011W	-	2
36"	1441011W	-	2
42"	1841011W	-	2
48"	1541011W	-	2
513mm	1641011W	1641211W	1
1000mm	1741011W	-	2

- Lined with a chemically resistant molded liner and has one black phenolic shelf.
- Add Option Code VK to order a Corrugated Polyolefin Vent Kit.

Width	Right Hinged	Left Hinged	# of Doors
15"	1946022W	1946222W	1
18"	1146022W	1146222W	1
24"	1246022W	1246222W	1
30"	1346022W	-	2
36"	1446022W	-	2
42"	1846022W	-	2
48"	1546022W	-	2
513mm	1646022W	1646222W	1
1000mm	1746022W	-	2

- Lined with a chemically resistant molded liner and has one black phenolic shelf.
- False panels are 7-1/2" high.
- Add Option Code VK to order a Corrugated Polyolefin Vent Kit.
- Add Option Code 82 to change liner to a FRP liner.

*WOOD CASEWORK  
SPECIALTY CABINETS - ADA HEIGHT*

**Acid Storage Units (22" Deep)**

See page L9 for vent hole locations.

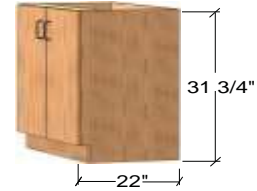

up to 24" wide



30" and wider



up to 24" wide



30" and wider

Width	Right Hinged	Left Hinged	# of Doors
15"	1981011W	1981211W	1
18"	1181011W	1181211W	1
24"	1281011W	1281211W	1
30"	1381011W	-	2
36"	1481011W	-	2
42"	1881011W	-	2
48"	1581011W	-	2
513mm	1681011W	1681211W	1
1000mm	1781011W	-	2

- Lined with a chemically resistant molded liner and has one black phenolic shelf.
- Add Option Code VK to order a Corrugated Polyolefin Vent Kit.
- Add Option Code 82 to change liner to a FRP liner.

Width	Right Hinged	Left Hinged	# of Doors
15"	1986022W	1986222W	1
18"	1186022W	1186222W	1
24"	1286022W	1286222W	1
30"	1386022W	-	2
36"	1486022W	-	2
42"	1886022W	-	2
48"	1586022W	-	2
513mm	1686022W	1686222W	1
1000mm	1786022W	-	2

- Lined with a chemically resistant molded liner and has one black phenolic shelf.
- False panels are 7-1/2" high.
- Add Option Code VK to order a Corrugated Polyolefin Vent Kit.
- Add Option Code 82 to change liner to a FRP liner.



*WOOD CASEWORK  
SPECIALTY CABINETS - STANDING HEIGHT*

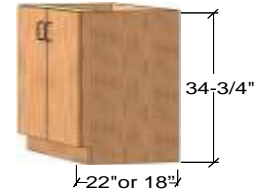

**Solvent Units (22" Deep)**

See page L9 for vent hole locations.



up to 24" wide

30" and wider

Width	Right Hinged	Left Hinged	# of Doors
15"	1912011W	1912111W	1
18"	1112011W	1112111W	1
24"	1212011W	1212111W	1
30"	1312011W	-	2
36"	1412011W	-	2
42"	1812011W	-	2
48"	1512011W	-	2
513mm	1612011W	1612111W	1
1000mm	1712011W	-	2

- Add Option Code 83 to order Self Closing doors. Cabinets over 24" wide will not be UL listed when option code 83 is added.
- Add Option Code "FL" to order a fusible link on Solvent cabinets with self-closing doors.



up to 24" wide

30" and wider

Width	Right Hinged	Left Hinged	# of Doors
15"	1912022W	1912122W	1
18"	1112022W	1112122W	1
24"	1212022W	1212122W	1
30"	1312022W	-	2
36"	1412022W	-	2
42"	1812022W	-	2
48"	1512022W	-	2
513mm	1612022W	1612122W	1
1000mm	1712022W	-	2

- Add Option Code 83 to order Self Closing doors. Cabinets over 24" wide will not be UL listed when option code 83 is added.
- Add Option Code "FL" to order a fusible link on Solvent cabinets with self-closing doors.
- Upper apron assemblies are 6" high. If Variac is required, upper aprons are 7-1/4" high. Not UL approved with electrical installed.
- Dimensional modifications may invalidate the UL listing - contact Mott for more information.

**Solvent Units (18" Deep)**



up to 24" wide

30" and wider

Width	Right Hinged	Left Hinged	# of Doors
15"	1932011W	1932111W	1
18"	1132011W	1132111W	1
24"	1232011W	1232111W	1
30"	1332011W	-	2
36"	1432011W	-	2
42"	1832011W	-	2
48"	1532011W	-	2
513mm	1632011W	1632111W	1
1000mm	1732011W	-	2

- Add Option Code 83 to order Self Closing doors. Cabinets over 24" wide will not be UL listed when option code 83 is added.
- Add Option Code "FL" to order a fusible link on Solvent cabinets with self-closing doors.



up to 24" wide

30" and wider

Width	Right Hinged	Left Hinged	# of Doors
15"	1932022W	1932122W	1
18"	1132022W	1132122W	1
24"	1232022W	1232122W	1
30"	1332022W	-	2
36"	1432022W	-	2
42"	1832022W	-	2
48"	1532022W	-	2
513mm	1632022W	1632122W	1
1000mm	1732022W	-	2

- Add Option Code 83 to order Self Closing doors. Cabinets over 24" wide will not be UL listed when option code 83 is added.
- Add Option Code "FL" to order a fusible link on Solvent cabinets with self-closing doors.
- Upper apron assemblies are 6" high. If Variac is required, upper aprons are 7-1/4" high. Not UL approved with electrical installed.
- Dimensional modifications may invalidate the UL listing - contact Mott for more information.

*WOOD CASEWORK  
SPECIALTY CABINETS - SITTING HEIGHT*

**Solvent Units (22" Deep)**

See page L9 for vent hole locations.

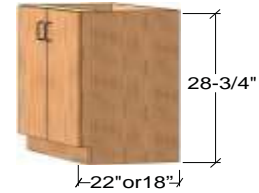

up to 24" wide



30" and wider

Width	Right Hinged	Left Hinged	# of Doors
15"	1922011W	1922111W	1
18"	1122011W	1122111W	1
24"	1222011W	1222111W	1
30"	1322011W	-	2
36"	1422011W	-	2
42"	1822011W	-	2
48"	1522011W	-	2
513mm	1622011W	1622111W	1
1000mm	1722011W	-	2

- Add Option Code 83 to order Self Closing doors. Cabinets over 24" wide will not be UL listed when option code 83 is added.
- Add Option Code "FL" to order a fusible link on Solvent cabinets with self-closing doors.

**Solvent Units (18" Deep)**



up to 24" wide



30" and wider

Width	Right Hinged	Left Hinged	# of Doors
15"	1942011W	1942111W	1
18"	1142011W	1142111W	1
24"	1242011W	1242111W	1
30"	1342011W	-	2
36"	1442011W	-	2
42"	1842011W	-	2
48"	1542011W	-	2
513mm	1642011W	1642111W	1
1000mm	1742011W	-	2

- Add Option Code 83 to order Self Closing doors. Cabinets over 24" wide will not be UL listed when option code 83 is added.
- Add Option Code "FL" to order a fusible link on Solvent cabinets with self-closing doors.

*SPECIALTY CABINETS - ADA HEIGHT*

**Solvent Units (22" Deep)**



up to 24" wide



30" and wider

Width	Right Hinged	Left Hinged	# of Doors
15"	1982011W	1982111W	1
18"	1182011W	1182111W	1
24"	1282011W	1282111W	1
30"	1382011W	-	2
36"	1482011W	-	2
42"	1882011W	-	2
48"	1582011W	-	2
513mm	1682011W	1682111W	1
1000mm	1782011W	-	2

- Add Option Code 83 to order Self Closing doors. Cabinets over 24" wide will not be UL listed when option code 83 is added.
- Add Option Code "FL" to order a fusible link on Solvent cabinets with self-closing doors.



*WOOD CASEWORK  
SPECIALTY CABINETS - STANDING HEIGHT*

**Pump Storage Cabinets (22" Deep)**

See page L9 for vent hole locations.

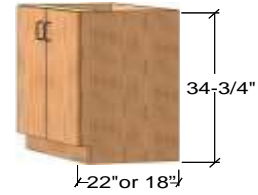

up to 24" wide



30" and wider

Width	Right Hinged	Left Hinged	# of Doors
15"	191P011W	191P211W	1
18"	111P011W	111P211W	1
24"	121P011W	121P211W	1
30"	131P011W	-	2
36"	141P011W	-	2
42"	181P011W	-	2
48"	151P011W	-	2
513mm	161P011W	161P211W	1
1000mm	171P011W	-	2

- See "Note 1" on page L8.
- Add option code PF for optional pump storage cabinet fan.



up to 24" wide



30" and wider

Width	Right Hinged	Left Hinged	# of Doors
15"	191P022W	191P222W	1
18"	111P022W	111P222W	1
24"	121P022W	121P222W	1
30"	131P022W	-	2
36"	141P022W	-	2
42"	181P022W	-	2
48"	151P022W	-	2
513mm	161P022W	161P222W	1
1000mm	171P022W	-	2

- See "Note 2" on page L8.
- Add option code PF for optional pump storage cabinet fan.

**Pump Storage Cabinets (18" Deep)**



up to 24" wide



30" and wider

Width	Right Hinged	Left Hinged	# of Doors
15"	193P011W	193P211W	1
18"	113P011W	113P211W	1
24"	123P011W	123P211W	1
30"	133P011W	-	2
36"	143P011W	-	2
42"	183P011W	-	2
48"	153P011W	-	2
513mm	163P011W	163P211W	1
1000mm	173P011W	-	2

- See "Note 1" on page L8.
- Add option code PF for optional pump storage cabinet fan.



up to 24" wide



30" and wider

Width	Right Hinged	Left Hinged	# of Doors
15"	193P022W	193P222W	1
18"	113P022W	113P222W	1
24"	123P022W	123P222W	1
30"	133P022W	-	2
36"	143P022W	-	2
42"	183P022W	-	2
48"	153P022W	-	2
513mm	163P022W	163P222W	1
1000mm	173P022W	-	2

- See "Note 2" on page L8.
- Add option code PF for optional pump storage cabinet fan.

*WOOD CASEWORK  
SPECIALTY CABINETS - SITTING HEIGHT*

**Pump Storage Cabinets (22" Deep)**

See page L9 for vent hole locations.

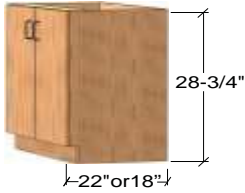

up to 24" wide

30" and wider

Width	Right Hinged	Left Hinged	# of Doors
15"	192P011W	192P211W	1
18"	112P011W	112P211W	1
24"	122P011W	122P211W	1
30"	132P011W	-	2
36"	142P011W	-	2
42"	182P011W	-	2
48"	152P011W	-	2
513mm	162P011W	162P211W	1
1000mm	172P011W	-	2

- See "Note 1" on page L8.
- Add option code PF for optional pump storage cabinet fan.



up to 24" wide

30" and wider

Width	Right Hinged	Left Hinged	# of Doors
15"	192P022W	192P222W	1
18"	112P022W	112P222W	1
24"	122P022W	122P222W	1
30"	132P022W	-	2
36"	142P022W	-	2
42"	182P022W	-	2
48"	152P022W	-	2
513mm	162P022W	162P222W	1
1000mm	172P022W	-	2

- See "Note 2" on page L8.
- Add option code PF for optional pump storage cabinet fan.

**Pump Storage Cabinets (18" Deep)**



up to 24" wide

30" and wider

Width	Right Hinged	Left Hinged	# of Doors
15"	194P011W	194P211W	1
18"	114P011W	114P211W	1
24"	124P011W	124P211W	1
30"	134P011W	-	2
36"	144P011W	-	2
42"	184P011W	-	2
48"	154P011W	-	2
513mm	164P011W	164P211W	1
1000mm	174P011W	-	2

- See "Note 1" on page L8.
- Add option code PF for optional pump storage cabinet fan.



up to 24" wide

30" and wider

Width	Right Hinged	Left Hinged	# of Doors
15"	194P022W	194P222W	1
18"	114P022W	114P222W	1
24"	124P022W	124P222W	1
30"	134P022W	-	2
36"	144P022W	-	2
42"	184P022W	-	2
48"	154P022W	-	2
513mm	164P022W	164P222W	1
1000mm	174P022W	-	2

- See "Note 2" on page L8.
- Add option code PF for optional pump storage cabinet fan.

*WOOD CASEWORK  
SPECIALTY CABINETS - ADA HEIGHT*

**Pump Storage Cabinets (22" Deep)**

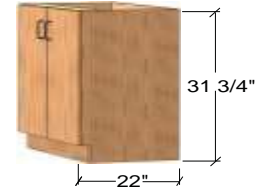

up to 24" wide



30" and wider

Width	Right Hinged	Left Hinged	# of Doors
15"	198P011W	198P211W	1
18"	118P011W	118P211W	1
24"	128P011W	128P211W	1
30"	138P011W	-	2
36"	148P011W	-	2
42"	188P011W	-	2
48"	158P011W	-	2
513mm	168P011W	168P211W	1
1000mm	178P011W	-	2

**Note 1:**

- Pump Storage Cabinets with full doors are insulated with sound absorption foam for noise reduction.
- Vent hose connection and 120V/20 amp (15 amp in Canada) duplex receptacle is located on the rear of the cabinet.
- Cabinets come complete with a pull-out shelf and removable access panel at the back of the cabinet.
- Add Option Code PF for optional pump cabinet fan.
- Vibration isolators are available, contact Mott Manufacturing for details.
- Fan information: 115 VAC  
120 X 120 X 38mm  
81 CFM



up to 24" wide



30" and wider

Width	Right Hinged	Left Hinged	# of Doors
15"	198P022W	198P222W	1
18"	118P022W	118P222W	1
24"	128P022W	128P222W	1
30"	138P022W	-	2
36"	148P022W	-	2
42"	188P022W	-	2
48"	158P022W	-	2
513mm	168P022W	168P222W	1
1000mm	178P022W	-	2

**Note 2:**

- Pump Storage Cabinets with a false panel are insulated with sound absorption foam for noise reduction.
- Vent hose connection is located on the rear of these cabinets.
- These cabinets are supplied with switch and outlet pre-wired to junction box on back panel.
- False panels on these cabinets are 7-1/2" high.
- Switch shown on the false panel controls interior 120V/20amp (15 amp in Canada) duplex receptacle for remote ON/OFF control.
- Cabinets come complete with a pull-out shelf and removable access panel at the back of the cabinet.
- Add Option Code PF for optional pump cabinet fan.
- Vibration isolators are available, contact Mott Manufacturing for details.
- Fan information: 115 VAC  
120 X 120 X 38mm  
81 CFM

*WOOD CASEWORK*  
*SPECIALTY CABINET VENT HOLE LOCATIONS*

**Acid Cabinet Vent Hole Location**

Acid cabinets are lined with a chemically resistant molded polyethylene liner (molded liners are removable). 3/16" thick fiberglass reinforced plastic lined cabinets are an available option. Removable liner is held in place with capped stainless steel screws and has a vent connection. Each cabinet has one black phenolic shelf. Cabinets are marked "ACID" - in red letters.

Note: Acid Cabinets must be vented. Mott recommends venting acid cabinets with a Polyolefin Vent Kit (PVSS for Molded Tub liner cabinets or PVSA for FRP liner cabinets - see page P51). Vent location applies to 28-3/4", 31-3/4" and 34-3/4" height cabinets.

**Acid Cabinet Rear View**

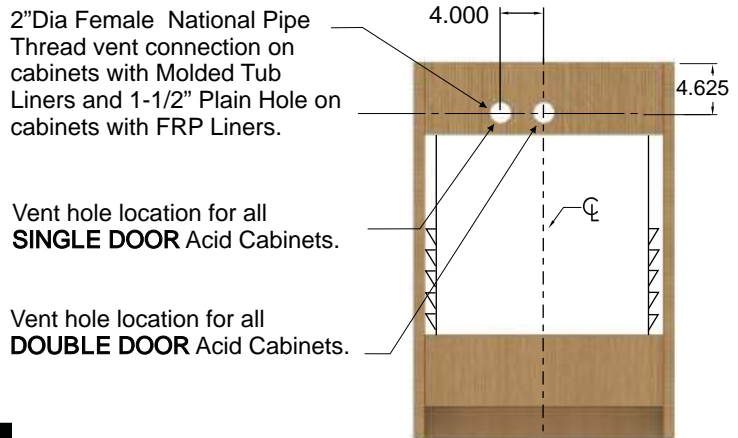

**Solvent Cabinet Vent Hole Location**

Solvent Storage cabinets are approved to UL1275, and meet National Fire Protection Association standards. The floor of the cabinet has a 2" deep liquid tight spill containment pan. Doors are mounted on continuous hinges with a three point locking self latching handle. Optional self closing doors and self closing/latching doors with a fusible link are also available. Each cabinet has two 2" diameter vents in the rear of the cabinet, complete with flame arrestor and vent covers. Each cabinet has one wood shelf. Cabinets are marked "FLAMMABLE KEEP FIRE AWAY" - in red letters.

Note: Fire code does not require Solvent Cabinets to be vented. Do not vent Solvent Cabinets to fume hood. If cabinet must be vented use fireproof pipe. Contact Mott for details. Vent location applies to 28-3/4", 31-3/4", 34-3/4" height cabinets.

**Solvent Cabinet Rear View**

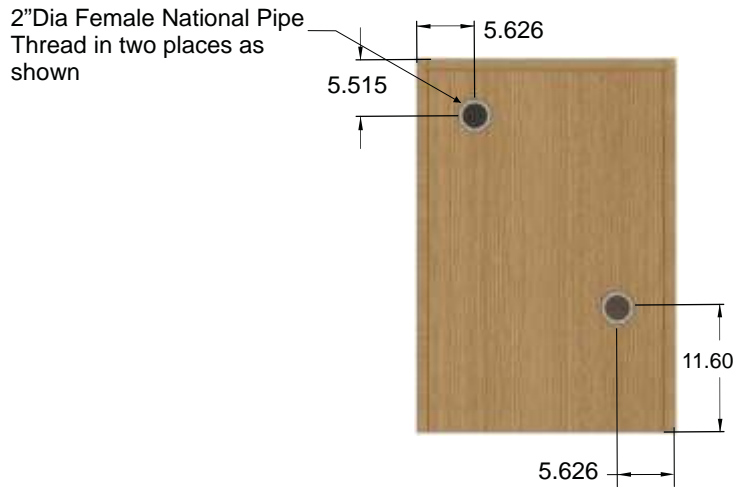

**Pump Storage Cabinet Vent Hole Location**

Pump cabinets are insulated with 1" thick acoustic foam which provides sound absorption and noise reduction over a wide range of frequencies. Foam is attached to the interior of the cabinet including the door by an adhesive backing on the foam. The foam is fire resistant and complies with MVSS 302 AND U194 HF-1 requirements. Two vent holes are incorporated into the cabinet back for connections to centralized lab exhaust systems. Custom vent cutouts are available. Back access panel is easily removable to provide convenient access to venting or electrical connections after installation. One 120 Volt / 20 Amp (15 Amp in Canada) electrical duplex receptacle provides power to the vacuum pump (final power connection required). The switch that controls receptacles is located on the front panel on False Panel Units; Full height Door Units are typically wired through the fume hood.

**Pump Storage Cabinet Rear**

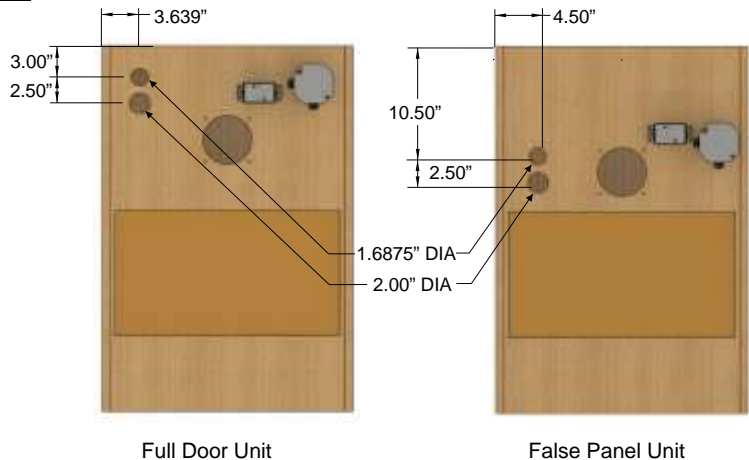

*WOOD CASEWORK  
SUSPENDED CABINETS*

**Open Units**



Width	Item Number
15"	1950000W
18"	1150000W
24"	1250000W
30"	1350000W
36"	1450000W
42"	1850000W
48"	1550000W
513mm	1650000W
1000mm	1750000W

**Full Door Units**



up to 24" wide



30" and wider

Width	Right Hinged	Left Hinged	# of Doors
15"	1950011W	1950211W	1
18"	1150011W	1150211W	1
24"	1250011W	1250211W	1
30"	1350011W	-	2
36"	1450011W	-	2
42"	1850011W	-	2
48"	1550011W	-	2
513mm	1650011W	1650211W	1
1000mm	1750011W	-	2

**Door/Drawer Units**



up to 24" wide



30" and wider

Width	Right Hinged	Left Hinged	# of Doors
15"	1950022W	1950222W	1
18"	1150022W	1150222W	1
24"	1250022W	1250222W	1
30"	1350022W	-	2
36"	1450022W	-	2
42"	1850022W	-	2
48"	1550022W	-	2
513mm	1650022W	1650222W	1
1000mm	1750022W	-	2

- Cabinets up to 24" wide receive one shelf.
- Cabinets over 30" wide do not have a shelf.



Width	Left Hand	Right Hand
30"	1350014W	1350041W
36"	1450014W	1450041W
42"	1850014W	1850041W
48"	1550014W	1550041W
1000mm	1750014W	1750041W

- Left hand Door/Drawer Unit shown.
- Right hand Door/Drawer Units are reverse of what is shown.



*WOOD CASEWORK  
SUSPENDED CABINETS*

**Drawer Units**

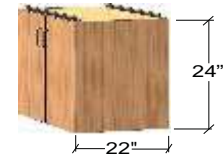

up to 24" wide



30" and wider

Width	Item Number
15"	1950044W
18"	1150044W
24"	1250044W
30"	1350044W
36"	1450044W
42"	1850044W
48"	1550044W
513mm	1650044W
1000mm	1750044W



up to 24" wide



30" and wider

Width	Item Number
15"	1950055W
18"	1150055W
24"	1250055W
30"	1350055W
36"	1450055W
42"	1850055W
48"	1550055W
513mm	1650055W
1000mm	1750055W



up to 24" wide



30" and wider

Width	Item Number
15"	1950066W
18"	1150066W
24"	1250066W
30"	1350066W
36"	1450066W
42"	1850066W
48"	1550066W
513mm	1650066W
1000mm	1750066W



Width	Item Number
30"	1350097W
36"	1450097W
42"	1850097W
48"	1550097W
1000mm	1750097W

*WOOD CASEWORK  
SUSPENDED CABINETS*

**Drawer Units**



Width	Item Number
30"	1350098W
36"	1450098W
42"	1850098W
48"	1550098W
1000mm	1750098W

**File Drawer Units**



up to 24" wide



30" and wider

Width	Item Number
15"	1950122W
18"	1150122W
24"	1250122W
30"	1350122W
36"	1450122W
42"	1850122W
48"	1550122W
513mm	1650122W
1000mm	1750122W



up to 24" wide



30" and wider

Width	Item Number
15"	1950177W
18"	1150177W
24"	1250177W
30"	1350177W
36"	1450177W
42"	1850177W
48"	1550177W
513mm	1650177W
1000mm	1750177W



up to 24" wide



30" and wider

Width	Item Number
15"	1950188W
18"	1150188W
24"	1250188W
30"	1350188W
36"	1450188W
42"	1850188W
48"	1550188W
513mm	1650188W
1000mm	1750188W



*WOOD CASEWORK  
SUSPENDED CABINETS*

**Sliding Door Units**

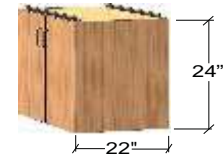

Width	Item Number
30"	1350711W
36"	1450711W
42"	1850711W
48"	1550711W
1000mm	1750711W

**Sink Units**



up to 24" wide



30" and wider

Width	Right Hinged	Left Hinged	# of Doors
15"	1953011W	1953211W	1
18"	1153011W	1153211W	1
24"	1253011W	1253211W	1
30"	1353011W	-	2
36"	1453011W	-	2
42"	1853011W	-	2
48"	1553011W	-	2
513mm	1653011W	1653211W	1
1000mm	1753011W	-	2

**Acid Storage Units**



up to 24" wide



30" and wider

Width	Right Hinged	Left Hinged	# of Doors
15"	1951011W	1951211W	1
18"	1151011W	1151211W	1
24"	1251011W	1251211W	1
30"	1351011W	-	2
36"	1451011W	-	2
42"	1851011W	-	2
48"	1551011W	-	2
513mm	1651011W	1651211W	1
1000mm	1751011W	-	2

- Acid Storage Units have an FRP liner.

**Solvent Storage Units**



up to 24" wide



30" and wider

Width	Right Hinged	Left Hinged	# of Doors
15"	1952011W	1952111W	1
18"	1152011W	1152111W	1
24"	1252211W	1252111W	1
30"	1352011W	-	2
36"	1452011W	-	2
42"	1852011W	-	2
48"	1552011W	-	2
513mm	1652011W	1652111W	1
1000mm	1752011W	-	2

- Solvent Units are designed to meet OSHA and NFPA 30 standards.
- Add option code 83 to order self closing/latching doors.
- Add option code FL to order self closing/latching doors with a fusible link.

*WOOD CASEWORK  
SUSPENDED CABINETS*

**Open Units**



Width	Item Number
15"	1960000W
18"	1160000W
24"	1260000W
30"	1360000W
36"	1460000W
42"	1860000W
48"	1560000W
513mm	1660000W
1000mm	1760000W

**Full Door Unit**



up to 24" wide



30" and wider

Width	Right Hinged	Left Hinged	# of Doors
15"	1960011W	1960211W	1
18"	1160011W	1160211W	1
24"	1260011W	1260211W	1
30"	1360011W	-	2
36"	1460011W	-	2
42"	1860011W	-	2
48"	1560011W	-	2
513mm	1660011W	1660211W	1
1000mm	1760011W	-	2

**Door/Drawer Units**



up to 24" wide



30" and wider

Width	Right Hinged	Left Hinged	# of Doors
15"	1960022W	1960222W	1
18"	1160022W	1160222W	1
24"	1260022W	1260222W	1
30"	1360022W	-	2
36"	1460022W	-	2
42"	1860022W	-	2
48"	1560022W	-	2
513mm	1660022W	1660222W	1
1000mm	1760022W	-	2



Width	Item Number
30"	1360041W
36"	1460041W
42"	1860041W
48"	1560041W
1000mm	1760041W

*WOOD CASEWORK  
SUSPENDED CABINETS*



**Drawer Units**



up to 24" wide

30" and wider

Width	Item Number
15"	1960044W
18"	1160044W
24"	1260044W
30"	1360044W
36"	1460044W
42"	1860044W
48"	1560044W
513mm	1660044W
1000mm	1760044W

**File Drawer Units**



up to 24" wide

30" and wider

Width	Item Number
15"	1960177W
18"	1160177W
24"	1260177W
30"	1360177W
36"	1460177W
42"	1860177W
48"	1560177W
513mm	1660177W
1000mm	1760177W

**Sink Units**



up to 24" wide

30" and wider

Width	Right Hinged	Left Hinged	# of Doors
15"	1963011W	1963211W	1
18"	1163011W	1163211W	1
24"	1263011W	1263211W	1
30"	1363011W	-	2
36"	1463011W	-	2
42"	1863011W	-	2
48"	1563011W	-	2
513mm	1663011W	1663211W	1
1000mm	1763011W	-	2

**Hanging Rails**



Width	Item Number
15"	HR00015
18"	HR00018
24"	HR00024
30"	HR00030
36"	HR00036
42"	HR00042
48"	HR00048
513mm	HR00020
1000mm	HR00040

- Pair of Hanging Rails only suitable for wood suspended cabinets.



*WOOD CASEWORK  
MISCELLANEOUS - FILLER PANELS*

**Front Filler Panels**



- The Front Filler Panel is used to close a space between two base cabinets.
- Available in sitting height (28-3/4"), ADA height (31-3/4") and standing height (34-3/4").
- Filler panels can be ordered in 1" increments, up to 24" wide. Change the last two digits to the dimension required.

Width	Sitting Hgt.	Standing Hgt.	ADA Hgt.
1"	FFC2001W	FFC1001W	FFC8001W
2"	FFC2002W	FFC1002W	FFC8002W
4"	FFC2004W	FFC1004W	FFC8004W
6"	FFC2006W	FFC1006W	FFC8006W
8"	FFC2008W	FFC1008W	FFC8008W
10"	FFC2010W	FFC1010W	FFC8010W
12"	FFC2012W	FFC1012W	FFC8012W
24"	FFC2024W	FFC1024W	FFC8024W

**Corner Filler Panels**



- The Corner Filler Panel is used to close a corner space between two base cabinets.
- Available in sitting height (28-3/4"), ADA height (31-3/4") and standing height (34-3/4").

Width	Sitting Hgt.	Standing Hgt.	ADA Hgt.
1" x 1"	CFC2001W	CFC1001W	CFC8001W
2" x 2"	CFC2002W	CFC1002W	CFC8002W
4" x 4"	CFC2004W	CFC1004W	CFC8004W
6" x 6"	CFC2006W	CFC1006W	CFC8006W

**End Cover Panels**



- The End Cover Channel performs the same task as the End Cover Panel Scribe but is of a fixed width.
- Available in sitting height (28-3/4"), ADA height (31-3/4") and standing height (34-3/4").
- Filler panels can be ordered in 1" increments, up to 24" wide. Change the last two digits to the dimension required.

Width	Sitting Hgt.	Standing Hgt.	ADA Hgt.
1"	ECC2001W	ECC1001W	ECC5001W
2"	ECC2002W	ECC1002W	ECC5002W
4"	ECC2004W	ECC1004W	ECC5004W
7"	ECC2007W	ECC1007W	ECC5007W
13"	ECC2013W	ECC1013W	ECC5013W
14"	ECC2014W	ECC1014W	ECC5014W
120mm	ECC200AW	ECC100AW	ECC500AW

**Tall Front Filler Panels**



- Tall Front Filler Panels are used to close a space between two floor cabinets.
- Filler panels can be ordered in 1" increments, up to 24" wide. Change the last two digits to the dimension required.

Width	84" High
1"	FFC3001W
2"	FFC3002W
3"	FFC3003W
4"	FFC3004W
8"	FFC3008W
10"	FFC3010W
12"	FFC3012W
24"	FFC3024W

**Tall End Cover Panels**



- Tall End Cover Channels perform the same task as the End Cover Panel Scribes, but is of a fixed width.
- Filler panels can be ordered in 1" increments, up to 24" wide. Change the last two digits to the dimension required.

Width	84" High
1"	ECC3001W
2"	ECC3002W
3"	ECC3003W
4"	ECC3004W
7"	ECC3007W
8"	ECC3008W



*WOOD CASEWORK  
MISCELLANEOUS - WALL FILLERS & VALANCES*

**Front Wall Fillers - 14" Deep**



- The Wall Filler is used to close a space between two wall cabinets.
- Filler panels can be ordered in 1" increments, up to 24" wide. Change the last two digits to the dimension required.

Width	24" High	30" High	36" High	48" High
1"	WFP5301W	WFP6301W	WFP7301W	WFP8301W
2"	WFP5302W	WFP6302W	WFP7302W	WFP8302W
3"	WFP5303W	WFP6303W	WFP7303W	WFP8303W
4"	WFP5304W	WFP6304W	WFP7304W	WFP8304W
6"	WFP5306W	WFP6306W	WFP7306W	WFP8306W
8"	WFP5308W	WFP6308W	WFP7308W	WFP8308W
10"	WFP5310W	WFP6310W	WFP7310W	WFP8310W
12"	WFP5312W	WFP6312W	WFP7312W	WFP8312W
15"	WFP5315W	WFP6315W	WFP7315W	WFP8315W
18"	WFP5318W	WFP6318W	WFP7318W	WFP8318W
24"	WFP5324W	WFP6324W	WFP7324W	WFP8324W

**Front Wall Fillers - 18" Deep**



- The Wall Filler is used to close a space between two wall cabinets.
- Filler panels can be ordered in 1" increments, up to 24" wide. Change the last two digits to the dimension required.

Width	24" High	30" High	36" High	48" High
1"	WFP5201W	WFP6201W	WFP7201W	WFP8201W
2"	WFP5202W	WFP6202W	WFP7202W	WFP8202W
3"	WFP5203W	WFP6203W	WFP7203W	WFP8203W
4"	WFP5204W	WFP6204W	WFP7204W	WFP8204W
6"	WFP5206W	WFP6206W	WFP7206W	WFP8206W
8"	WFP5208W	WFP6208W	WFP7208W	WFP8208W
10"	WFP5210W	WFP6210W	WFP7210W	WFP8210W
12"	WFP5212W	WFP6212W	WFP7212W	WFP8212W
18"	WFP5218W	WFP6218W	WFP7218W	WFP8218W
19"	WFP5219W	WFP6219W	WFP7219W	WFP8219W
24"	WFP5224W	WFP6224W	WFP7224W	WFP8224W

**Light Valances**

- Light valances are to be fastened to the bottom of a wall cabinet. Available with left side, right side, or both returns.
- Light valance are 3" high.



- Left hand return Light Valance shown.
- Right hand return Light Valances are reverse of what is shown.
- Horizontal wood grain is standard.

Width	Right Side Return		Left Side Return	
	12" Return	16" Return	12" Return	16" Return
18"	VPR3018W	VPR4018W	VPL3018W	VPL4018W
24"	VPR3024W	VPR4024W	VPL3024W	VPL4024W
30"	VPR3030W	VPR4030W	VPL3030W	VPL4030W
36"	VPR3036W	VPR4036W	VPL3036W	VPL4036W
42"	VPR3042W	VPR4042W	VPL3042W	VPL4042W
48"	VPR3048W	VPR4048W	VPL3048W	VPL4048W
60"	VPR3060W	VPR4060W	VPL3060W	VPL4060W
72"	VPR3072W	VPR4072W	VPL3072W	VPL4072W
96"	VPR3096W	VPR4096W	VPL3096W	VPL4096W



- Use 12" deep Light Valance for a 14" deep wall cabinet.
- Use 16" deep Light Valance for a 18" deep wall cabinet.
- Light valance returns are 2" shorter in depth than the standard depth of the cabinet, to allow for clearance of opening and closing the doors above.
- Horizontal wood grain is standard.

Width	Right & Left Side Returns	
	12" Return	16" Return
18"	VPS3018W	VPS4018W
24"	VPS3024W	VPS4024W
30"	VPS3030W	VPS4030W
36"	VPS3036W	VPS4036W
42"	VPS3042W	VPS4042W
48"	VPS3048W	VPS4048W
60"	VPS3060W	VPS4060W
72"	VPS3072W	VPS4072W
96"	VPS3096W	VPS4096W

*WOOD CASEWORK  
MISCELLANEOUS - VALANCES, FRONT RAILS & FRONT RAIL COVERS*

**Light Valances**



- Front only Light Valance to be fastened to the bottom of a wall cabinet.
- 3" high.
- Horizontal wood grain is standard.

Width	Front Only
18"	VPF1018W
24"	VPF1024W
30"	VPF1030W
36"	VPF1036W
42"	VPF1042W
48"	VPF1048W
60"	VPF1060W
72"	VPF1072W
96"	VPF1096W

**Front Rails**



• 3-3/4" high.

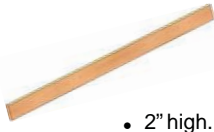

• 2" high.

- Front Rails are commonly used to finish a space at a sitting area when a full frame apron is not required.
- Sides are not edge banded.

Width	3-3/4"H	2"H
18"	FRA0018W	FRB0018W
24"	FRA0024W	FRB0024W
30"	FRA0030W	FRB0030W
36"	FRA0036W	FRB0036W
42"	FRA0042W	FRB0042W
48"	FRA0048W	FRB0048W
54"	FRA0054W	FRB0054W
60"	FRA0060W	FRB0060W
66"	FRA0066W	FRB0066W
72"	FRA0072W	FRB0072W
513mm	FRA000AW	FRB000AW
1000mm	FRA000BW	FRB000BW

**Front Rail Service Covers**



- Front Rail Service Cover panels are used to conceal open spaces and services where front rails are in place
- Attaches to adjacent cabinets and meets the underside of the work surface.
- Assembly includes single angles for attachment to adjacent cabinets. Upper panel is removable to allow access to the services. The lower panel stays fixed in order to apply covered base and overlapping the lower and upper panel allows to accommodate for uneven floors.
- Available in sitting height (28-3/4"), ADA height (31-3/4") and standing height (34-3/4").

Width	Sitting Hgt.	Standing Hgt.	ADA Hgt.
15"	SCP2015W	SCP1015W	SCP5015W
18"	SCP2018W	SCP1018W	SCP5018W
24"	SCP2024W	SCP1024W	SCP5024W
30"	SCP2030W	SCP1030W	SCP5030W
36"	SCP2036W	SCP1036W	SCP5036W
42"	SCP2042W	SCP1042W	SCP5042W
48"	SCP2048W	SCP1048W	SCP5048W
54"	SCP2054W	SCP1054W	SCP5054W
60"	SCP2060W	SCP1060W	SCP5060W
66"	SCP2066W	SCP1066W	SCP5066W
513mm	SCP200AW	SCP100AW	SCP500AW
1000mm	SCP200BW	SCP100BW	SCP500BW



*WOOD CASEWORK  
MISCELLANEOUS - APRONS & APRON COVERS*

**Apron Units - 22" Deep**



- Aprons provide a work area from a seated position.
- Aprons are available with or without drawers.
- 3-3/4" high, three piece adjustable construction.

Width	Plain Front	With Drawers	# of Drawers
24"	AUC0124W	AUA0124W	1
30"	AUC0130W	AUA0130W	1
36"	AUC0136W	AUA0136W	1
42"	AUC0142W	AUA0142W	1
48"	AUC0148W	AUA0148W	2
54"	AUC0154W	AUA0154W	2
60"	AUC0160W	AUA0160W	2
66"	AUC0166W	AUA0166W	2
72"	AUC0172W	AUA0172W	2
513mm	AUC010AW	AUA010AW	1
1000mm	AUC010BW	AUA010BW	1

**Apron Units 28" Deep**



- Aprons provide a work area from a seated position.
- Aprons are available with or without drawers.
- 3-3/4" high, three piece adjustable construction.

Width	Plain Front	With Drawers	# of Drawers
24"	AUC0424W	AUA0424W	1
30"	AUC0430W	AUA0430W	1
36"	AUC0436W	AUA0436W	1
42"	AUC0442W	AUA0442W	1
48"	AUC0448W	AUA0448W	2
54"	AUC0454W	AUA0454W	2
60"	AUC0460W	AUA0460W	2
66"	AUC0466W	AUA0466W	2
72"	AUC0472W	AUA0472W	2
513mm	AUC040AW	AUA040AW	1
1000mm	AUC040BW	AUA040BW	1

**Arched Rail Apron Units**



- Aprons provide a work area from a seated position.
- 2" high front and rear rails.

Width	22" Deep	28" Deep
24"	AUC0224W	AUC0324W
30"	AUC0230W	AUC0330W
36"	AUC0236W	AUC0336W
42"	AUC0242W	AUC0342W
48"	AUC0248W	AUC0348W
54"	AUC0254W	AUC0354W
60"	AUC0260W	AUC0360W
66"	AUC0266W	AUC0366W
72"	AUC0272W	AUC0372W
513mm	AUC020AW	AUC030AW
1000mm	AUC020BW	AUC030BW

**Apron Service Covers**



- Apron Service Cover panels are used to conceal open spaces and services below aprons.
- Attaches to adjacent cabinets and meets the underside of the bottom of the apron.
- Assembly includes single angles for attachment to adjacent cabinets. Upper panel is removable to allow access to the services. The lower panel stays fixed in order to apply covered base and overlapping the lower and upper panel allows to accommodate for uneven floors.
- Available in sitting height (25"), ADA height (28") and standing height (31").

Width	Sitting Hgt.	Standing Hgt.	ADA Hgt.
15"	SCP4015W	SCP3015W	SCP6015W
18"	SCP4018W	SCP3018W	SCP6018W
24"	SCP4024W	SCP3024W	SCP6024W
30"	SCP4030W	SCP3030W	SCP6030W
36"	SCP4036W	SCP3036W	SCP6036W
42"	SCP4042W	SCP3042W	SCP6042W
48"	SCP4048W	SCP3048W	SCP6048W
54"	SCP4054W	SCP3054W	SCP6054W
60"	SCP4060W	SCP3060W	SCP6060W
66"	SCP4066W	SCP3066W	SCP6066W
513mm	SCP400AW	SCP300AW	SCP600AW
1000mm	SCP400BW	SCP300BW	SCP600BW



*WOOD CASEWORK  
MISCELLANEOUS - SUPPORT, GABLE & TABLE LEGS*



**Support Legs**



- Legs are used to support Island counter tops or Aprons where base cabinets are not required.
- Available in sitting height (28-3/4"), ADA height (31-3/4") and standing height (34-3/4").
- 3/4" thick.
- Nominal depths shown in chart.
- Actual depths 1-3/4" less than nominal.

Depth	Sitting Hgt.	Standing Hgt.	ADA Hgt.
28"	GLD2028W	GLD1028W	GLD3028W
29"	GLD2029W	GLD1029W	GLD3029W
34"	GLD2034W	GLD1034W	GLD3034W
35"	GLD2035W	GLD1035W	GLD3035W
46"	GLD2046W	GLD1046W	GLD3046W
52"	GLD2052W	GLD1052W	GLD3052W
58"	GLD2058W	GLD1058W	GLD3058W

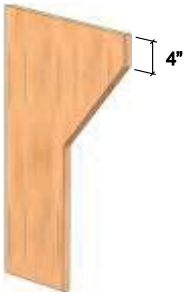

- Legs are used to support counter tops or Aprons where base cabinets are not required.
- Lower portion depth is half of overall depth.
- Available in sitting height (28-3/4"), ADA height (31-3/4") and standing height (34-3/4").
- 3/4" thick.
- Nominal depths shown in chart.
- Actual depths 7/8" less than nominal.

Depth	Sitting Hgt.	Standing Hgt.	ADA Hgt.
22"	GLA2022W	GLA1022W	GLA3022W
23"	GLA2023W	GLA1023W	GLA3023W
29"	GLA2029W	GLA1029W	GLA3029W
35"	GLA2035W	GLA1035W	GLA3035W

**Gable Legs**



- Gable Legs are used to support counter tops or Aprons where base cabinets are not required.
- Complete with finished wood cleats.
- Available in sitting height (28-3/4"), ADA height (31-3/4") and standing height (34-3/4").
- 3/4" thick.
- Nominal depths shown in chart.
- Actual depths 7/8" less than nominal.

Depth	Sitting Hgt.	Standing Hgt.	ADA Hgt.
22"	GLS2022W	GLS1022W	GLS3022W
23"	GLS2023W	GLS1023W	GLS3023W
29"	GLS2029W	GLS1029W	GLS3029W
35"	GLS2035W	GLS1035W	GLS3035W

**Table Legs**



- Table Legs are used to support counter tops where base cabinets are not present.
- Leveling bolts and PVC boots are included.
- Available in sitting height (28-3/4"), ADA height (31-3/4") and standing height (34-3/4").
- 2-1/8" wide by 2-1/8" deep.

Height	Item Number
28-3/4"	3200000W
34-3/4"	3100000W
31-3/4"	3500000W

*WOOD CASEWORK  
MISCELLANEOUS - SERVICE DROPS*

**Full Access Island Service Drops**

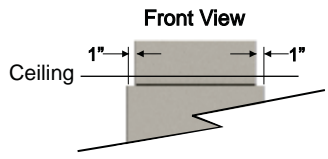
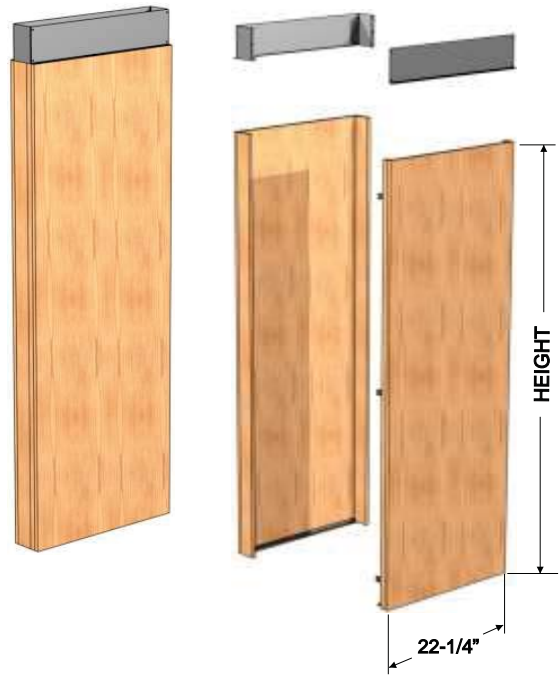

Height	Item Number
68"	SDP1368W
73"	SDP1373W
78"	SDP1378W
90"	SDP1390W

- Use to carry utilities from the counter top up through the ceiling.
- Service Drop offers full height (from counter top to ceiling) access to services.
- Front panel attaches with 'Z' clip.

**Full Access Wall Service Drops**

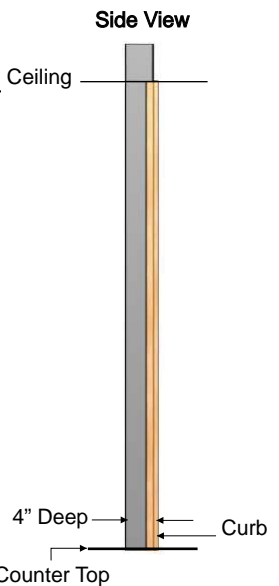
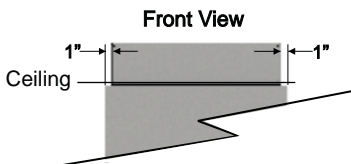

Height	Item Number
68"	SDP1468W
73"	SDP1473W
78"	SDP1478W
90"	SDP1490W

- Use to carry utilities from the counter top up through the ceiling.
- Service Drop offers full height (from counter top to ceiling) access to services.
- Front panel attaches with 'Z' clip.
- Designed to fit on a 22" wide x 5" high x 4" deep curb.

*WOOD CASEWORK  
MISCELLANEOUS - SERVICE DROPS & SHELVES*

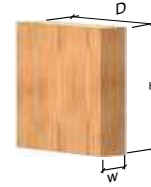

**Service Drops**



Top View



Height	6" Deep		8" Deep	
	12" Wide	24" Wide	12" Wide	24" Wide
78"	SDP3078W	SDP4078W	SDP1078W	SDP2078W
90"	SDP3090W	SDP4090W	SDP1090W	SDP2090W

- Use to carry utilities from the counter top up through the ceiling.
- For Wall and Island applications.
- Each assembly consists of two 12" high fixed upper and lower panels and a removable center panel.
- 78" high service drop has 54" center lift off panel.
- 90" high service drop has 66" center lift off panel.

**Sigma Flex™ Wood Shelves**



Wood Shelves							
Width	6" Deep	8" Deep	10" Deep	12" Deep	14" Deep	18" Deep	24" Deep
24"	FSH0624W	FSH0824W	FSH1024W	FSH1224W	FSH1424W	FSH1824W	FSH2424W
30"	FSH0630W	FSH0830W	FSH1030W	FSH1230W	FSH1430W	FSH1830W	FSH2430W
36"	FSH0636W	FSH0836W	FSH1036W	FSH1236W	FSH1436W	FSH1836W	FSH2436W
42"	FSH0642W	FSH0842W	FSH1042W	FSH1242W	FSH1442W	FSH1842W	FSH2442W
48"	FSH0648W	FSH0848W	FSH1048W	FSH1248W	FSH1448W	FSH1848W	FSH2448W
54"	FSH0654W	FSH0854W	FSH1054W	FSH1254W	FSH1454W	FSH1854W	FSH2454W
60"	FSH0660W	FSH0860W	FSH1060W	FSH1260W	FSH1460W	FSH1860W	FSH2460W

- Shelf suitable for any Sigma Flex™ support structure or Sigma Cart™.
- Attach to shelf brackets with screws (screws not included).
- Nominal width.
- For wood shelving options see page N8.

*WOOD CASEWORK  
MISCELLANEOUS - SHELF OPTIONS*

**Wood Shelving Options**



Height	Back Lip	Front Lip	Back and Front Lip
1"	ARW1	AFW1	ABW1
2"	ARW2	AFW2	ABW2
3"	ARW3	AFW3	ABW3
4"	ARW4	AFW4	ABW4

- Height of the lip is measured from the top of the shelf to the top of the lip. Lip is 3/4" thick.
- Shelves are 1" thick.

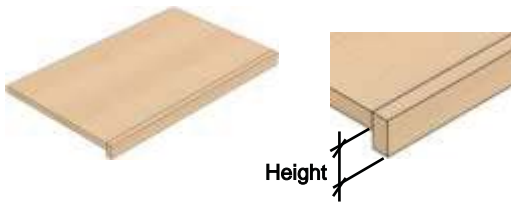

Height	Front Valance
1"	FV1
2"	FV2
3"	FV3
4"	FV4

- Height of the valance is measured from the bottom of the shelf to the bottom of the valance. Valance is 3/4" thick.
- Shelves are 1" thick.



Height	Bookends
4"	BE4
5"	BE5
6"	BE6

- Height of the bookends are measured from the top of the shelf to the top of the bookends. Bookends are 3/4" thick.
- Shelves are 1" thick.



Height	Bookends With Raised Lip at Back
4"	3BE4
5"	3BE5
6"	3BE6

- Height of the bookends and rear lip are measured from the top of the shelf to the top of the bookends or lip. Bookends and rear lip are 3/4" thick.
- Shelves are 1" thick.



Bookends with Raised Lip at Back			
Bookend Height	Raised Lip at Back		
	1"H	2"H	3"H
4"	BR41	BR42	BR43
5"	BR51	BR52	BR53
6"	BR61	BR62	BR63

- Height of the bookends and rear lip are measured from the top of the shelf to the top of the bookends or lip. Bookends and rear lip are 3/4" thick.
- Shelves are 1" thick.

**Shelf Retainer Rods**



Retainer Rod Options	
Position on Shelf	Stainless Steel
Front	SR
Back	SRB
Sides	SRS
Front and Back	SRFB
Front and Sides	SRFS
Back and Sides	SRBS
All Four Sides	SRAS

- 1" high retainer rod (5/16" dia.) prevents articles from falling off the shelf.
- Can be added to existing shelves of different materials.
- Threaded retainer rod includes hardware for mounting to shelf (shelf must have holes drilled to accept rod).
- Ships loose.

*WOOD CASEWORK  
MISCELLANEOUS - PANELS*

**Finished Back Panels**



- The Finished Back Panels are used to close off the back of a base cabinet when the back is in plain view.
- Available in sitting height (28-3/4"), ADA height (31-3/4") or standing height (34-3/4").

**Extended Finished Back Panels**



- The Extended Finished Back Panels are used to close off the back of a base cabinet when the back is in plain view.
- Available in sitting height (28-3/4"), ADA height (31-3/4") or standing height (34-3/4").

**Wall Cabinet Furring Panels**



- Wall Cabinet Furring Panels are used to close off the area between the top of a wall cabinet and the ceiling.
- Wall Cabinet Furring Panels sit flush with cabinet body.
- 24" high.
- Depth dimensions are nominal.

Width	Sitting Hgt	Standing Hgt	ADA Hgt
15"	FBP2015W	FBP1015W	FBP6015W
18"	FBP2018W	FBP1018W	FBP6018W
24"	FBP2024W	FBP1024W	FBP6024W
30"	FBP2030W	FBP1030W	FBP6030W
36"	FBP2036W	FBP1036W	FBP6036W
42"	FBP2042W	FBP1042W	FBP6042W
48"	FBP2048W	FBP1048W	FBP6048W

Width	Sitting Height		
	6" Return	8" Return	12" Return
15"	FEC1506W	FEC1508W	FEC1512W
18"	FEC1806W	FEC1808W	FEC1812W
24"	FEC2406W	FEC2408W	FEC2412W
30"	FEC3006W	FEC3008W	FEC3012W
36"	FEC3606W	FEC3608W	FEC3612W
42"	FEC4206W	FEC4208W	FEC4212W
48"	FEC4806W	FEC4808W	FEC4812W
60"	FEC6006W	FEC6008W	FEC6012W
72"	FEC7206W	FEC7208W	FEC7212W

Width	Standing Height		
	6" Return	8" Return	12" Return
15"	FEA1506W	FEA1508W	FEA1512W
18"	FEA1806W	FEA1808W	FEA1812W
24"	FEA2406W	FEA2408W	FEA2412W
30"	FEA3006W	FEA3008W	FEA3012W
36"	FEA3606W	FEA3608W	FEA3612W
42"	FEA4206W	FEA4208W	FEA4212W
48"	FEA4806W	FEA4808W	FEA4812W
60"	FEA6006W	FEA6008W	FEA6012W
72"	FEA7206W	FEA7208W	FEA7212W

Width	ADA Height		
	6" Return	8" Return	12" Return
15"	FED1506W	FED1508W	FED1512W
18"	FED1806W	FED1808W	FED1812W
24"	FED2406W	FED2408W	FED2412W
30"	FED3006W	FED3008W	FED3012W
36"	FED3606W	FED3608W	FED3612W
42"	FED4206W	FED4208W	FED4212W
48"	FED4806W	FED4808W	FED4812W
60"	FED6006W	FED6008W	FED6012W
72"	FED7206W	FED7208W	FED7212W

Width	14" Deep	18" Deep	22" Deep
18"	FPS1018W	FPS2018W	FPS3018W
24"	FPS1024W	FPS2024W	FPS3024W
30"	FPS1030W	FPS2030W	FPS3030W
36"	FPS1036W	FPS2036W	FPS3036W
42"	FPS1042W	FPS2042W	FPS3042W
48"	FPS1048W	FPS2048W	FPS3048W
60"	FPS1060W	FPS2060W	FPS3060W
72"	FPS1072W	FPS2072W	FPS3072W
96"	FPS1096W	FPS2096W	FPS3096W
1000mm	FPS100BW	FPS200BW	FPS300BW

*WOOD CASEWORK  
MISCELLANEOUS - STUDENT ASSEMBLIES*

**Double Sided Student Workstation**

- Double Sided Student Workstations are designed to be used from both sides.
- Dimensions of 58" wide by 46" deep are available in sitting height (28-3/4") and standing height (34-3/4").
- Cabinet configurations are identical on each side of the assembly and are separated by 10" wide filler and include two pass through book compartments.
- Standing height workstations cabinets are 30" wide by 36" high by 18" deep.
- Sitting height workstations cabinets are 30" wide by 30" high by 18" deep.
- A variety of assemblies are available with different cabinet configurations. Please contact Mott for details.
- Counter tops are not included.



Sitting Hgt.	Standing Hgt.
DSW0200W	DSW0100W

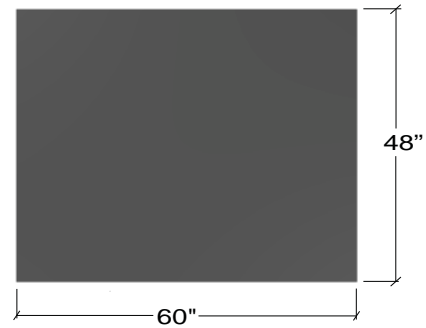

Required Counter Top Detail



Sitting Hgt.	Standing Hgt.
DSW0220W	DSW0120W



Sitting Hgt.	Standing Hgt.
DSW0210W	DSW0110W

*WOOD CASEWORK  
MISCELLANEOUS - STUDENT ASSEMBLIES*

**Double Sided Student Workstation**

- Double Sided Student Workstations are designed to be used from both sides.
- Dimensions of 58" wide by 46" deep are available in sitting height (28-3/4") and standing height (34-3/4").
- Cabinet configurations are identical on each side of the assembly and are separated by 10" wide filler and include two pass through book compartments.
- Standing height workstations cabinets are 30" wide by 36" high by 18" deep.
- Sitting height workstations cabinets are 30" wide by 30" high by 18" deep.
- A variety of assemblies are available with different cabinet configurations. Please contact Mott for details.
- Counter tops are not included.



Sitting Hgt.	Standing Hgt.
DSW0230W	DSW0130W

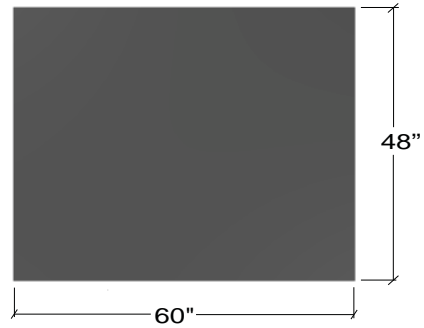

Required Counter Top Detail



Sitting Hgt.	Standing Hgt.
DSW0231W	DSW0131W



Sitting Hgt.	Standing Hgt.
DSW0232W	DSW0132W



*WOOD CASEWORK  
MISCELLANEOUS - STUDENT ASSEMBLIES*

**Quad Student Workstation**

- Quad Student Workstations are designed to be used from all sides.
- Dimensions of 58" wide by 58" deep are available in sitting height (28-3/4") and standing height (34-3/4").
- Cabinet configurations are identical on each side of the assembly and include accessible center space.
- Cabinet dimensions are 24" wide by 20" high by 15" deep.
- Quantity of four (one per side) 120volt, 20 amperage electrical receptacles are optional.
- A variety of assemblies are available with different cabinet configurations. Please contact Mott for details.
- Cabinets have a removable back in order to access a 19" Wide by 10-1/4" High cutout in pedestal.
- Counter tops are not included.



Workstation with electrical receptacles show.

Options	Sitting Hgt.	Standing Hgt.
Plain	QSW0200W	QSW0100W
With Electrical	QSWE200W	QSWE100W

Options	Sitting Hgt.	Standing Hgt.
Plain	QSW0220W	QSW0120W
With Electrical	QSWE220W	QSWE120W

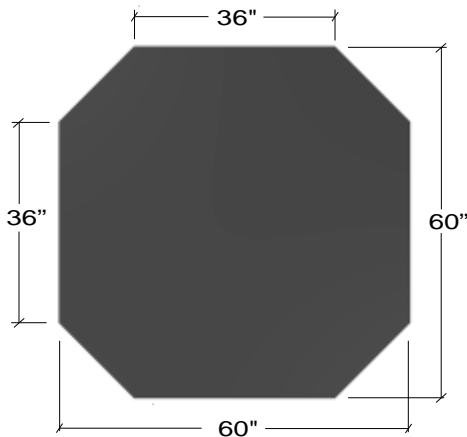

**Required Counter Top Detail**

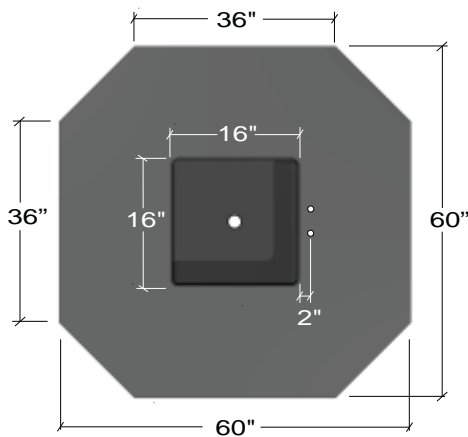

**Required Counter with Sink Top Detail**

- Maximum sink size is 16" x 16" with fixture holes located 2" from any side of the sink edge to center of fixture hole.

*WOOD CASEWORK  
MISCELLANEOUS - STUDENT ASSEMBLIES*

**Quad Student Workstation**

- Quad Student Workstations are designed to be used from all sides.
- Dimensions of 58" wide by 58" deep are available in sitting height (28-3/4") and standing height (34-3/4").
- Cabinet configurations are identical on each side of the assembly and include accessible center space.
- Cabinet dimensions are 24" wide by 20" high by 15" deep.
- Quantity of four (one per side) 120volt, 20 amperage electrical receptacles are optional.
- A variety of assemblies are available with different cabinet configurations. Please contact Mott for details.
- Cabinets have a removable back in order to access a 19" Wide by 10-1/4" High cutout in pedestal.
- Counter tops are not included.



Workstation with electrical receptacles show.

Options	Sitting Hgt.	Standing Hgt.
Plain	QSW0212W	QSW0112W
With Electrical	QSWE212W	QSWE112W

Options	Sitting Hgt.	Standing Hgt.
Plain	QSW0211W	QSW0110W
With Electrical	QSWE211W	QSWE110W

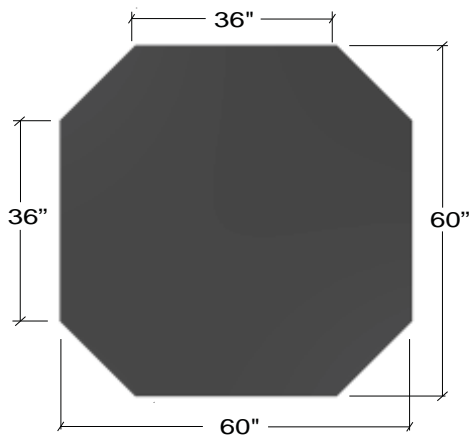

**Required Counter Top Detail**

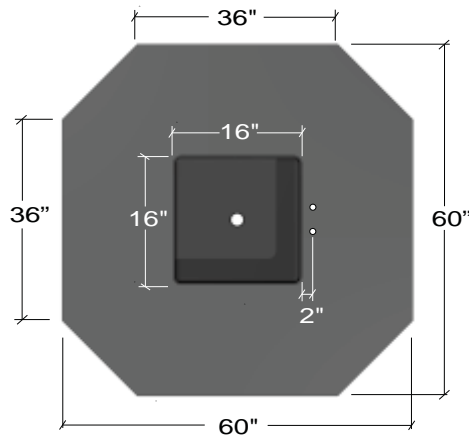

**Required Counter with Sink Top Detail**

- Maximum sink size is 16" x 16" with fixture holes located 2" from any side of the sink edge to center of fixture hole.

*WOOD CASEWORK  
MISCELLANEOUS - STUDENT ASSEMBLIES & DEMONSTRATION STATIONS*

**Two & Four Student Cabinet Storage Workstations**

These are samples of some of the student storage workstations Mott offers. A variety of assemblies are available with different cabinet configurations in various dimensions. For additional information and help in planning contact Mott Manufacturing.



**Demonstration Stations**

These are samples of some of the demonstration workstations Mott offers. A variety of assemblies are available with different cabinet configurations in various dimensions. For additional information and help in planning contact Mott Manufacturing.



*STAINLESS STEEL  
PRODUCTS*

**Stainless Steel Introduction**

The full range of Mott cabinetry - from base cabinets to tall floor mounted cabinets - are available in 304 or 316 stainless steel. Mott Manufacturing specializes in the integration of custom design features and/or dimensions into stainless steel laboratory furniture components. The following is a sample listing of other furniture components that can be manufactured in 304 or 316 stainless steel:

- Counter tops
- Filler panels
- Aprons
- Tables - fixed and mobile
- Exhaust canopies

**Stainless Steel Grades**

The most common stainless steel grades required in laboratory applications are 304 or 316. 304 grade is widely used for cabinetry while the 316 grade is more often specified for more demanding applications such as counter tops and fume hood liners. Note: Stainless Steel is generally not suited for acid labs or labs where chlorides will be used.

304 grade stainless steel is the most versatile and one of the most widely applied stainless steel grades for laboratory use. High quality laboratory furniture components can be readily manufactured from this grade because it has excellent forming and welding characteristics. This grade also has excellent corrosion resistance, further corrosion resistance details are available from Mott Manufacturing or its dealers upon request.

316 grade stainless steel is specified for the more demanding laboratory environments. This molybdenum bearing, higher nickel content grade delivers superior corrosion resistance, improved stain resistance and strengthened chloride attack resistance benefits to laboratory furniture. This grade has excellent corrosion resistance to a wider range of chemicals, including the complex sulphur compounds.

All Mott stainless steel laboratory furniture components are manufactured to a No.4 finish to deliver a smooth sanitary surface. This finish is widely used in laboratory applications where a uniform bright finish is required. The No.4 finish delivered by Mott Manufacturing is often slightly brighter than industry standard as the mesh finish is in the range of 120 to 150 resulting from the stainless steel sheets being

polished with lubricating oil and abrasive belts with a 180 to 200 grit. No.4 finish samples are available from Mott or its dealers upon request.

**Counter Tops**

Counter tops can be designed to exactly match customer specifications and include features such as:

- Marine or finished edges (figure 1)
- Integral sinks in a wide variety of configurations
- Sloping drain boards

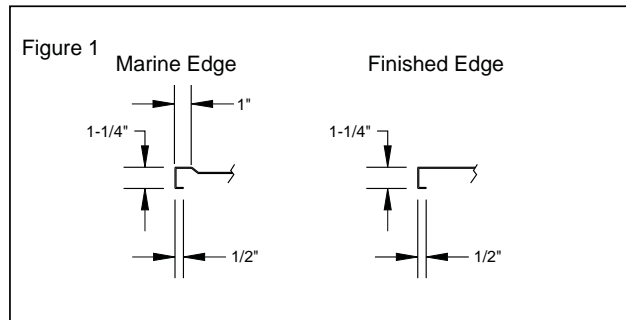

Standard construction includes either 304 or 316 stainless steel, backed by a 43 lb density particle board and plywood core (figure 2). Steel hat channel

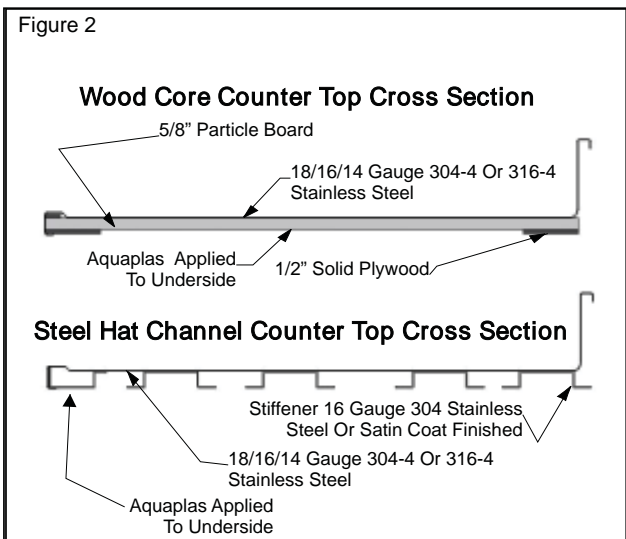

construction is also available with 16 gauge type 304 stainless steel or satin coat finished stiffeners. Hat channel construction is recommended for long length counter tops that support heavy equipment or instruments (figure 2). All Mott counter tops have a sound deadening Aquaplas sealer applied to their underside.

*STAINLESS STEEL  
PRODUCTS*

**Exhaust Canopies**

Exhaust canopies can be manufactured to customer specifications. Exhaust canopies are primarily used to exhaust steam, odors, and heat in work areas where the expense and capabilities of a fume hood are not justified. In addition to stainless steel, exhaust canopies are also available in painted galvanized or cold rolled steel. Features include:

- Integral duct stub
- Steel rod suspension
- Continuous condensate catch

Available options include:

- Interior lights
- Baffles
- Dampers

There are two basic types of stainless steel exhaust canopies, island exhaust canopies and wall exhaust canopies. Island exhaust canopies (figure 3) have four angled surfaces and are often used above an island workstation or where wall mounting is not practical. The sloped surfaces allow for easier housekeeping.

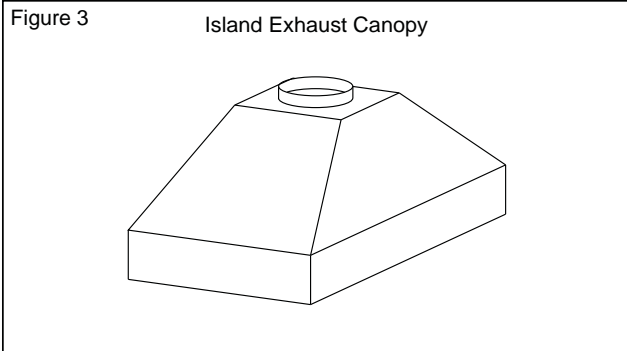

Wall exhaust canopies have 3 sloped surfaces and a flat rear surface to facilitate mounting to a wall (figure 4).

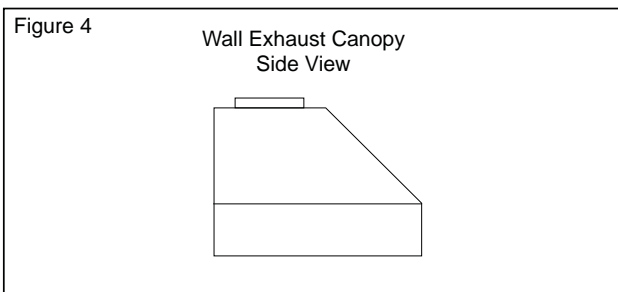

Exhaust canopies are most commonly constructed of 18 gauge 304 or 316 stainless steel.

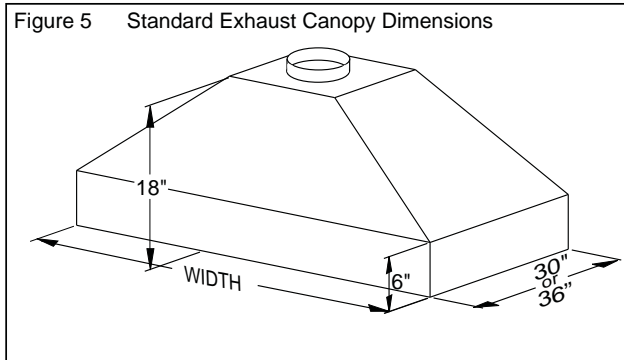

Exhaust canopies are manufactured to exact customer specifications. Part numbers for exhaust canopies are located on page P37 of the catalog.

**Other Stainless Steel Products**

All cabinets, filler panels, tables and aprons are available in stainless steel. Stainless steel cabinets are constructed of the same gauges of material as our standard product, but in 304-4 stainless and are equipped with stainless steel hinges and bar pulls.

- Drawer bodies, Shelves, Door & Drawer Liners, Removable Backs. 20 gauge
- Cabinet Gables, Tops, Bottoms, Toekicks, Outer Door and Drawer Front Panels, Table Frames, Filler Panels, Sloping Tops. 18 gauge
- Tops and Intermediate Channels, Table Legs. 16 gauge
- Drawer Suspension, Hinge Plates, Cabinet Leveler Support. 14 gauge

**Ordering Stainless Steel Product**

Ordering stainless steel cabinetry is accomplished by using our standard part numbers and stating any items to be made from stainless steel. Please specify the grade of stainless steel desired when ordering. Option code -51 is type 304-4 and option code -52 is type 316-4.

*STAINLESS STEEL  
CASEWORK CONSTRUCTION DETAILS AND SPECIFICATIONS*

**Overview**

**Cabinets**

Standard cabinets are fabricated using prime quality furniture grade 304-4 stainless steel. (Optional 316-4 Stainless Steel is also available using option code -51.) All components are die formed, notched, keyed and tightly fitted to form a

Stainless Steel Cabinet Gauges and Materials	
Drawer Bodies*, Shelves, Door and Drawer Liners, Removable Backs.	20 gauge 304-4 S/S
Cabinet Gables, Tops, Bottoms, Toekicks, Outer Door and Drawer Front Panels, Table Frames, Filler Panels, Sloping Tops.	18 gauge 304-4 S/S
Top and Intermediate Channels, Table Legs.	16 gauge 304-4 S/S
Drawer Suspension, Hinge Plates.	14 gauge 304-4 S/S
Cabinet Leveler Support	11 gauge 304-4 S/S
Five Knuckle Hinges (with s/s fasteners)	14 gauge 304-4 S/S
Door / Drawer Pulls	S/S Bar Pull
Door Roller Catch	Zinc Plated
3/8 Hex Head Leveler Bolts	Electro Plated
Drawer Roller Bearings	Zinc plated with Nylon rim
Full Extension Drawer Glides	Zinc plated
Shelf Clips	Zinc plated
Sliding Glass Doors Shoes & Tracks	Aluminum
Framed Glass Door lower Tracks	PVC
Cabinet Leveler Access Covers	PVC

**Note:** \* 30" wide or larger drawers are 18 gauge, otherwise drawers are standard 20 gauge.

**Finish**

All cabinets surfaces are finished to a No.4 brush. All weld marks on the cabinet front and sides, exterior and interior of drawer / door heads have the color removed. All welds including the rear and interior of the cabinet, and outside of drawer housings are left natural.

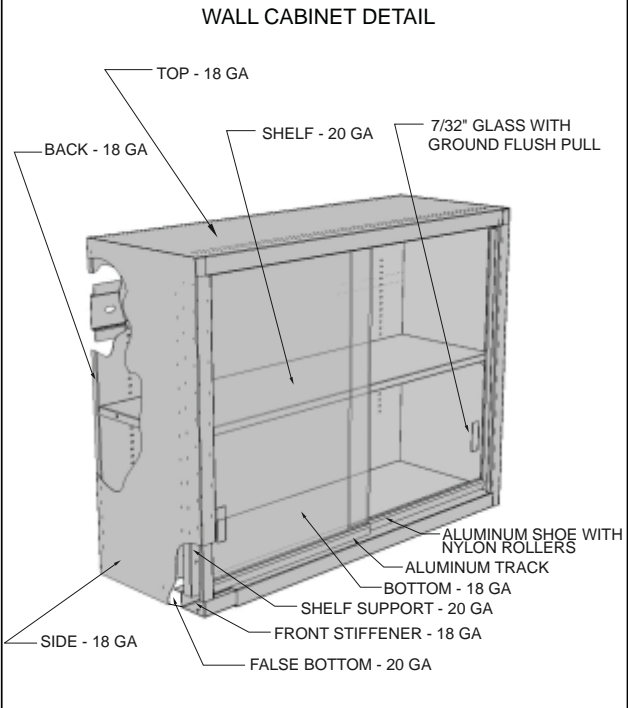
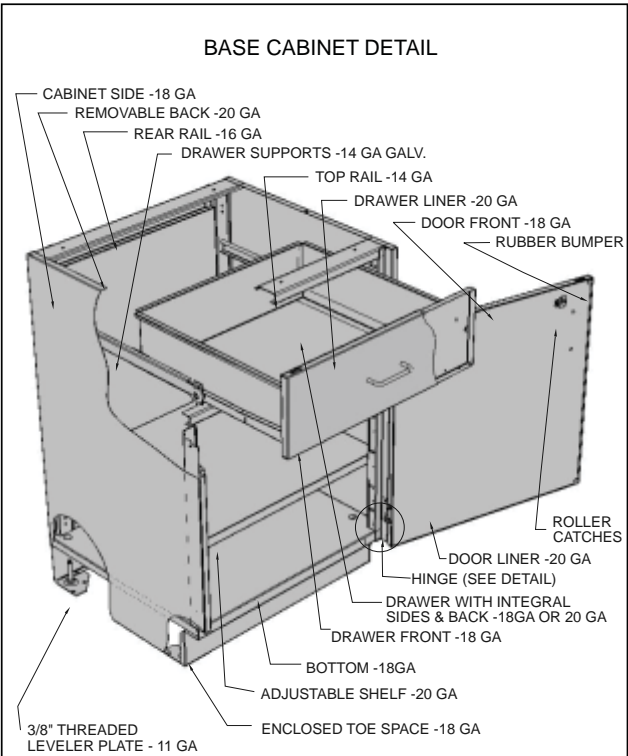

All dimensions and sizes shown are nominal. Specifications and details are based on product information at the time of printing and may change at any time without notice. Mott Manufacturing reserves the right to change dimensions, specifications and manufacturing details at any time without notice.



*FUME HOODS  
OVERVIEW*

**Fume Hood Introduction**

The safety of laboratory personnel is the single most important design criteria for all Mott fume hoods.

A fume hood properly designed, manufactured, installed, and operated will deliver a safe working environment to laboratory personnel. This important safety function requires the effective integration of the fume hood into the laboratory's HVAC (heating, ventilating, and air conditioning) system.

The safety purpose of a Mott fume hood is to:

- Capture, contain, and exhaust hazardous fumes, odors, and airborne particulate
- Contain liquids that are splashed or sprayed

The process of specifying the most appropriate fume hood requires an integrated approach that often involves the manufacturer (or its dealer), laboratory personnel, architects, laboratory planners, engineers, and contractors. Before specifying or ordering a fume hood, please review the following information in this section. Discuss any issues or concerns with a fume hood specialist.

The following overview is therefore provided as a resource to the participants of this integrated approach as it reviews:

1. Terminology
2. Face Velocity
3. Fume Hood Performance
4. Fume Hood Construction Details
5. Fume Hood Configurations

**1. TERMINOLOGY**

Consistent, uniform airflow across the fume hood opening is a critical performance requirement to deliver safety to laboratory personnel. The following terms help evaluate the fume hood's performance; Figure 1 illustrates these terms.

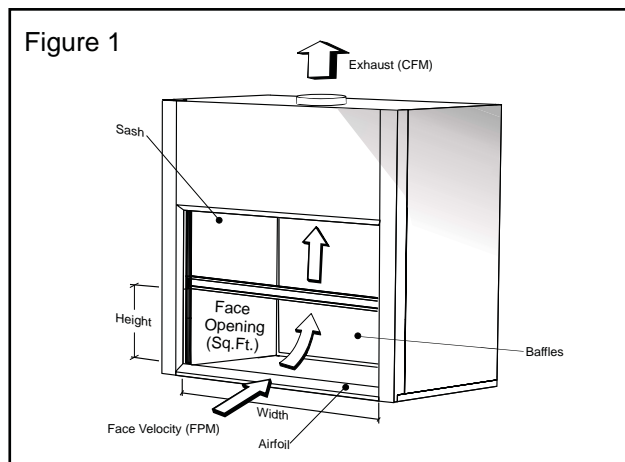

**Airfoil** is the stainless steel ledge at the bottom opening of the fume hood. It allows air to enter the fume hood when the sash is closed, and delivers uniform airflow across the entire lower surface of the fume hood when the sash is open.

**Baffles** are panels located across the fume hood rear wall that direct the air flow to the exhaust duct.

**Balance** is matching the conditioned supply air volume entering a room to the exhaust air volume. This air volume is measured in cubic feet per minute (cfm). Laboratory HVAC design usually requires a negative static pressure relative to adjacent rooms and corridors to prevent contaminants from escaping the laboratory.

**Constant Air Volume (CAV)** system exhausts approximately the same air volume (cfm) regardless of the fume hood sash position. Therefore as the sash closes, the face velocity increases.

**Containment** is the fume hood's ability to capture gases and vapors for effective exhaust. ASHRAE 110 is one standard that defines the protocol for containment testing. Containment is usually measured in parts per million (ppm).

**Exhaust Volume** is the volume of air that is exhausted from the fume hood. It is calculated by multiplying the face velocity (ft/min) by the face area (ft<sup>2</sup>) and is expressed in cubic feet per minute (ft<sup>3</sup>/min or cfm).



## FUME HOODS OVERVIEW

### Fume Hood Introduction

$$\text{Exhaust Volume} = \text{Face Velocity} \times \text{Face Area}$$

**Face Area** is the fume hood's front access or sash opening. It is calculated by multiplying the open sash width (ft) and height (ft) and is expressed in square feet (ft<sup>2</sup>).

$$\text{Face Area} = \text{Open Sash Width} \times \text{Open Sash Height}$$

**Face Velocity** is the average air speed entering the open sash. It can be measured by various measuring devices or calculated by dividing the exhaust volume (cfm) by the face area (ft<sup>2</sup>) and is expressed in feet per minute (ft/min or fpm).

$$\text{Face Velocity} = \text{Exhaust Volume} / \text{Face Area}$$

**Plenum** is a chamber that allows air flow to equalize.

**Sash** is the fume hood's moveable door usually made of laminated glass. Vertically raising, horizontal sliding, or a combination of both are the three most common sash types.

**Static Pressure** is pressure drop in an HVAC system resulting from duct bends and restrictions from various components such as a fume hood. It is expressed in inches of water gauge (in. WG).

**Variable Air Volume (VAV)** is a fume hood with controls that adjust the volumetric exhaust airflow rate in response to sash position changes. This adjustment in exhaust airflow maintains a constant average face velocity.

## 2. FACE VELOCITY

Seek advice from your lab planner for the proper face velocity for the hood chosen. Be sure to consider the fume hood application and set-up processes.

A properly designed, manufactured, installed, and operated fume hood will have a relatively consistent face velocity across the entire sash opening at any defined sash position.

At a defined sash position, velocity measurements taken at any point within the sash opening should not be less than 20% below the average of all the other measured points. Some laboratory guidelines require this velocity variance to be 10% maximum.

While several references and agencies provide face velocity recommendations, the generally accepted range for most applications is 80 to 120 ft/min. With some hood designs, velocities of 60 ft/min are satisfactory.

Sash position will affect the face velocity in a constant volume system. In most HVAC systems, a properly selected constant speed exhaust fan with no dampers will exhaust approximately the same volume of air (cfm) regardless of the sash position. This relatively constant relationship between sash position and exhaust volume results from the following operating characteristics:

- The fume hood's static pressure remains relatively constant regardless of the sash position.
- The fume hood is only one source of static pressure drop in the HVAC system and therefore a relatively small change in the fume hood static pressure as the sash position changes does not result in a significant change in the entire HVAC system's static pressure.

Therefore as the fume hood sash closes in a constant volume system, the face area decreases and the face velocity must increase to maintain the same exhaust volume. The calculations below for a typical 72 inch wide fume hood, as shown in Figure 2, demonstrate that closing the sash from the full open to half open position will double the face velocity.

At the sash full open position:

$$\begin{aligned} \text{Face area} &= \text{sash width} \times \text{sash open height} \\ &= 5.2 \text{ ft} \times 2.4 \text{ ft} \\ &= 12.5 \text{ square feet} \end{aligned}$$

Therefore at the sash full open position:

$$\begin{aligned} \text{Exhaust volume} &= \text{Face area} \times \text{Face Velocity} \\ &= 1250 \text{ ft}^3/\text{min} \end{aligned}$$

At the sash half open position:

$$\text{Face area} = 6.25 \text{ ft}^2 \text{ (one half the full open area)}$$

Since this is a constant volume system,

$$\text{Exhaust volume} = 1250 \text{ ft}^3/\text{min} \text{ (constant)}$$

Therefore at the sash half open position:

$$\begin{aligned} \text{Face Velocity} &= \text{Exhaust Volume} / \text{Face Area} \\ &= 200 \text{ ft}/\text{min} \end{aligned}$$

*FUME HOODS  
OVERVIEW*

**Fume Hood Introduction**

The face velocity at the sash half open position is therefore twice the face velocity at the sash full open position in a constant volume system.

This relationship of face velocity and exhaust volume has significant energy conservation consequences.

If the required face velocity is set at the sash half open operating position instead of the full open sash position, the required exhaust volume is reduced 50%. This reduced exhaust volume requirement will reduce the exhaust fan size and/or speed resulting in substantially reduced fan horsepower and operating costs. Operating costs associated with a fume hood can be significant since fully conditioned air is being exhausted from the laboratory to outside the building.

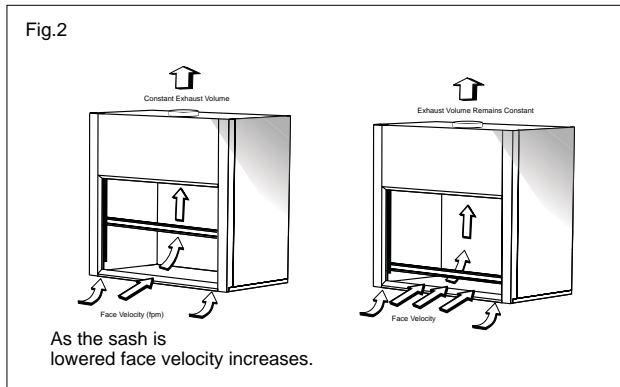

**3. FUME HOOD PERFORMANCE**

**A. Specifications**

Mott Pro fume hoods have been designed to meet or exceed the American National Standard for Laboratory Ventilation and the American Industrial Hygiene Association standard as outlined in ANSI/AIHA Z9.5-2012.

This performance has been verified through factory at testing according to the protocol established in the standard ANSI/ASHRAE 110. These published test results are available from Mott Manufacturing.

As a SEFA member (Scientific Equipment & Furniture Association), Mott Manufacturing has ensured that all its fume hoods are manufactured in compliance with the requirements of the latest edition of SEFA Recommended Practices specification.

**B. Face Velocity & Containment**

Mott Pro fume hoods have been designed to meet the face velocity and containment performance requirements of most laboratory applications.

The performance delivered will satisfy the requirements of the majority of laboratory requirements. The performance levels noted below have been confirmed by tests conducted to the ASHRAE 110 standard.

**Standard High Containment Baffle**

Face Velocity Variance: Max. 20% below average.  
Containment (ppm):0.050 maximum

Higher containment levels can be achieved.

*Meets American Industrial Hygiene Association  
Requirements for Safety*

**4. FUME HOOD CONSTRUCTION DETAILS**

Mott fume hoods are rigid, self supporting units manufactured for installation without a requirement for field fabrication or assembly.

Several optional features are available on all Mott Pro fume hoods; these options are outlined in each design's specification sheets included in this catalogue.

The following construction details are common for both the Mott Pro and Select fume hoods, except where noted.

**A. Double Wall Construction (Pro Series)**

Double wall construction accommodates plumbing and electrical wiring. The outer shell, corner posts, upper front panel, and furring panels can be manufactured from any of the following:

- Prime furniture grade cold rolled steel coated with Mott's chemical resistant high performance thermosetting laboratory grade powder.
- Satin coat (galvanized steel) coated with Mott's chemical resistant thermosetting laboratory grade powder.
- Stainless steel -304-4 or 316-4.

*FUME HOODS  
OVERVIEW*

**Fume Hood Introduction**

The inner shell can be manufactured from any of the following liners:

**Fume Hood Liner Selection**

	<p><b>FRP - Fiberglass reinforced polyester</b></p> <ul style="list-style-type: none"> <li>-white color, excellent general purpose liner</li> <li>-good resistance to most solvents, bases, and acids</li> <li>-low flame spread rating</li> <li>-strong structural strength</li> </ul>
	<p><b>316 Stainless steel square corners</b></p> <ul style="list-style-type: none"> <li>-resistant to solvents and bases</li> <li>-subject to attack by some acids</li> <li>-high tolerance to flame and heat</li> <li>-excellent structural strength</li> </ul>
	<p><b>316 Stainless steel rounded corners</b></p> <ul style="list-style-type: none"> <li>-resistant to solvents and bases</li> <li>-subject to attack by some acids</li> <li>-recommended for radioisotope and perchloric acid applications</li> <li>-high tolerance to flame and heat</li> <li>-excellent structural strength</li> <li>-excellent cleaning characteristics</li> </ul>
	<p><b>304 Stainless steel square corners</b></p> <ul style="list-style-type: none"> <li>-resistant to solvents and bases</li> <li>-subject to attack by some acids</li> <li>-high tolerance to flame and heat</li> <li>-excellent structural strength</li> </ul>
	<p><b>PVC - Polyvinyl chloride</b></p> <ul style="list-style-type: none"> <li>-white color</li> <li>-excellent resistance bases, and acids</li> <li>-poor tolerance to flame and heat</li> <li>-strong structural strength</li> </ul>
	<p><b>Epoxy resin</b></p> <ul style="list-style-type: none"> <li>-off white color</li> <li>-excellent resistance to solvents, bases, and acids</li> <li>-moderate tolerance to flame and heat</li> <li>-moderate structural strength</li> <li>-extended lead time</li> </ul>

Concealed stainless steel fasteners are used in all locations that are exposed to fumes. Furring panels and outside panels are fabricated of 18 gauge prime quality furniture grade cold rolled steel. Fume hoods are manufactured with factory installed round or rectangular (on selected models) exhaust collars mounted on the fume hood roof for convenient field duct connection.

**B. Electrical Components**

- Fume Hoods are CSA certified and UL 1805 Classified.
- All components are UL listed or CSA certified.
- Rapid start fluorescent light fixture mounted behind a vapor proof safety glass panel.
- Standard design includes a light switch and two 120 volt duplex receptacles mounted on the corner posts.
- Other customer specified electrical components can be factory installed as required.

**C. Baffles**

Baffles are manufactured of the same material as the liner and consist of three panels - the top angled baffle and the two piece lower baffle with intermediate air intake slots.

The standard fixed baffle design is a high containment baffle. Fixed baffles are recommended. They have been tested to perform well for all regular fume hood operations.

Standard baffle face velocity and containment performance as noted in 3B (page P3).

**D. Sash and Airfoil**

The full view vertical raising sash is manufactured of laminated safety glass with the sash set into an extruded, low turbulence PVC track that delivers smooth operation and steady sash positioning. Smooth operation of the sash is also delivered by a single appropriately balanced counterweight that is suspended on either:

- A stainless steel aircraft quality cable system complete with ball bearing pulleys or
- A high quality chain and ball sprocket system

To reduce the amount of exhaust air by as much as 40% add a sash stop at 18" open. This cuts down the amount of open face area, yet allows the operator to access the inside of the hood. The sash stop can be manually overridden when there are no hazards present for apparatus setup. For even greater savings of 50% add a combination vertical raising and horizontal sliding sash. Not only does this save energy it also acts as a face and body shield to protect the operator. Other energy saving options are available. Contact Mott manufacturing for details.

*FUME HOODS  
OVERVIEW*

**Fume Hood Introduction**

**D. Sash and Airfoil - Continued**

The air foil is mounted at the bottom of the hood opening and is aerodynamically designed to minimize turbulence and provide appropriate continuous flow even in the closed sash position.

**E. Exhaust Collars**

The exhaust collar connects the fume hood to the exhaust duct. Depending on the fume hood size, round collars are provided for direct connection to standard ducting without the need for costly transition assemblies. There may be one or two collars of either 10 or 12 inch diameter and is noted on each fume hood page. On certain models, rectangular collars are used and exhaust transitions are required to fit over the vent collar.

**F. Fume Hood Alarms**

To provide additional protection to laboratory personnel, Mott fume hoods can be supplied with air velocity monitors. These options provide continuous monitoring of the air flow through the fume hood complete with a visual and audible alarm in the event of abnormal air flow conditions. Monitors provide adjustable alarm set points and a test button to confirm satisfactory operation.

**5. FUME HOOD CONFIGURATIONS**

Mott fume hoods are available in several different configurations. These different designs are presented in the following manner.

**Configurations**

- Constant Volume By-Pass Configuration
- Auxiliary Air Configuration Variable Volume
- Restricted By-Pass Configuration
- Low Constant Volume

**Applications**

- Bench
- Fully accessible
- Perchloric acid
- Radioisotope
- Distillation
- Floor Mounted
- Demonstration

**A. Series**

Mott fume hoods are available in two basic series: Pro and Select.

Mott Pro Series is of double wall construction suitable for most laboratory requirements and available in several configurations each designed for a variety of applications.

Mott Select Series is of thin wall construction and suitable for some school laboratory requirements.

**B. Configurations**

Mott Pro Series fume hoods are available in configurations that represent the three fundamental airflow options.

Each of these four Mott Pro series configurations are available in several different application designs (distillation, radioisotope, walk-in, etc.) that are also detailed in this catalog. The four Mott Pro Series configurations are detailed below.

**a. Constant Air Volume Systems (CAV)**

Two basic fume hood configurations have been developed to operate in laboratory constant air volume (CAV) systems. These three configurations are:

**i. By-Pass Fume Hood Configuration**

The by-pass fume hood configuration incorporates louvers located in the upper front panel above the sash. These by-pass louvers, illustrated in Figure 4, provide an alternate path for air to enter the upper portion of the fume hood as the sash is closed.

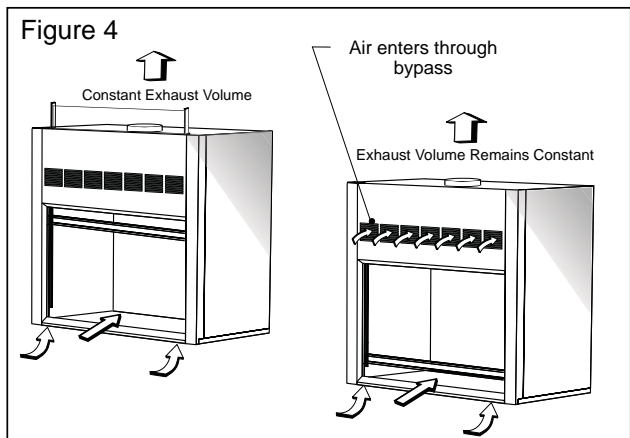

*FUME HOODS  
OVERVIEW*

**Fume Hood Introduction**

This configuration therefore maintains a relatively constant exhaust volume (cfm) from the fully open sash position to a sash position approximately 6 inches open above the airfoil.

Even with these by-pass louvers, the face velocity increases as the sash is adjusted towards the closed position, however the velocity increase is not as large as found in the conventional configuration.

If a by-pass configuration fume hood is specified to operate at a defined design face velocity at the sash full open position, the resulting face velocity when the sash is 6 inches above the fully closed position is approximately three times the design face velocity. This by-pass configuration face velocity ratio can be further reduced if the design face velocity is specified at working sash position of 18 inches open. In this case, as the sash is closed to 6 inches above the fully closed position, the resulting face velocity increased to approximately twice the design face velocity.

**ii. Auxiliary Air Fume Hood Configuration**

The auxiliary air (or supplemental air) fume hood is a by-pass configuration with an additional plenum installed on the upper front of the fume hood. This plenum delivers auxiliary air to the face opening of the fume hood from a separate air supply as shown in Figure 5.

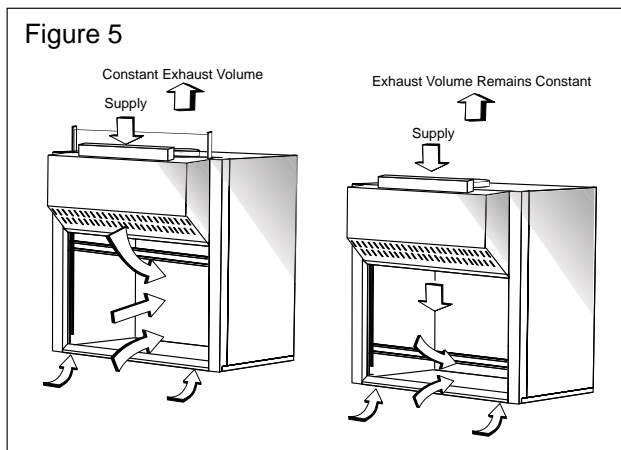

The auxiliary air is introduced above and over the face opening, allowing the auxiliary air to be washed over the operator and captured by the fume hood.

This configuration generally delivers an auxiliary air volume that is approximately 70% of the total fume

hood exhaust volume. The fume hood captures approximately 95% of the auxiliary air, therefore very little auxiliary air escapes into the laboratory.

Because the auxiliary air fume hood is also a constant volume configuration with a by-pass, increasing air volume enters the fume hood via the by-pass as the sash is closed.

Contemporary laboratory design often incorporates variable volume (VAV) systems, therefore the auxiliary configuration is less frequently specified. This VAV preference results from several operating characteristics of the auxiliary air configuration, namely:

- ∞ Auxiliary air fume hoods require relatively large amounts of incremental pre-conditioned air that is supplied through the plenum above the sash. The cost to pre-condition this air for the necessary operator comfort during the laboratory operating hours can be very significant in most North American climates.
- ∞ Increased material and labor installation costs associated with the independent air supply system together with the increased cost of this fume hood configuration must also be considered when specifying this configuration.
- ∞ The auxiliary air can potentially expose the process within the fume hood to detrimental turbulence thus reducing the fume hood's containment performance.

**b. Variable Air Volume (VAV) Systems**

Variable air volume systems vary the amount of exhaust air volume (cfm) as the fume hood sash is repositioned so that a relatively constant face velocity is maintained. There are several VAV system configurations installed in laboratories, however the basic principles remain the same.

**i. Restricted By-Pass Fume Hood Configuration**

Generally a VAV system incorporates a by-pass configuration fume hood that includes an additional adjustment blank-off plate mounted behind the louvers. The presence of this additional blank-off plate results in the use of the term "restricted by-pass". An electronic sash position sensor is also usually installed, as illustrated in Figure 6.



*FUME HOODS  
OVERVIEW*

**Fume Hood Introduction**

Figure 6

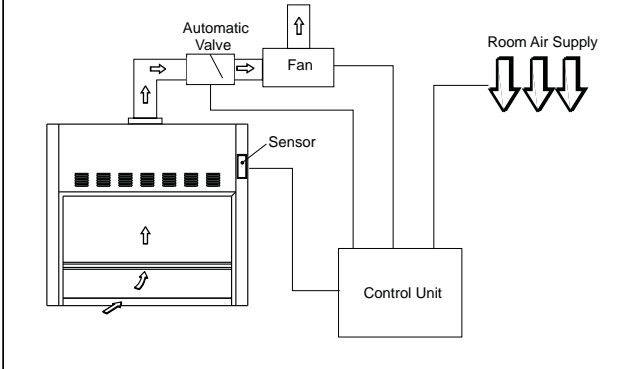

As the sash position is adjusted, an electronic signal is transmitted from the sash position sensor to an air volume controller. The exhaust air volume is controlled by valves, plates, or variable speed fans. The controller also concurrently adjusts the supply air into the laboratory to maintain proper air balance.

**IMPORTANT:**

Qualified professionals should determine the best hood for each application and how the supporting HVAC system is designed, since the fume hood is a significant component of a correctly designed HVAC system. The potential safety, reliability, and energy-savings benefits can only be the result of the entire system and building working together well as a whole. It is the responsibility of the laboratory specifier/planner to ensure the system coordinates jointly with the local and state codes.

When the sash is fully closed, the by-pass will open to allow approximately 10% to 20% of the corresponding sash full open air volume to enter the fume hood without creating excessive turbulence as noted in Figure 7. Therefore, when the sash is fully closed, a relative negative static pressure is maintained inside the fume hood thus delivering improved containment.

This configuration continues to increase in popularity because of its significant energy saving benefits, especially in multiple fume hood laboratories. While installation costs are higher for variable air volume systems, the reduced operating costs resulting from energy savings usually provide a payback in the range of three to six years.

**Fume Hood Applications**

**Bench Fume Hoods** are suitable for most laboratory

Figure 7

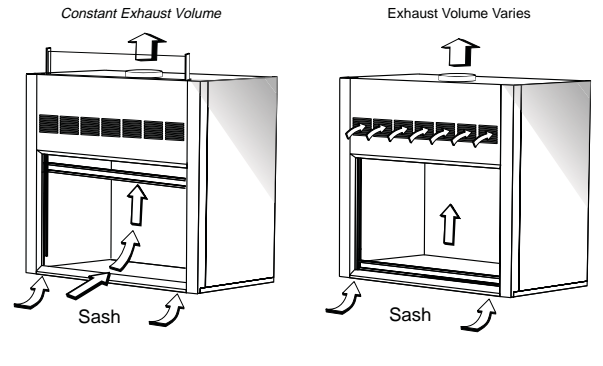

applications and are the most popular type. They are typically designed to mount on 30" deep work surfaces.

**Fully Accessible Fume Hoods** are designed to meet the needs of both able bodied and disabled laboratory users. When combined with the right laboratory cabinetry they meet ADA requirements.

**Perchloric Acid Fume Hoods** are designed specifically for perchloric acid procedures. All corners are welded and coved for ease of cleaning. They come equipped with an internal wash down system, and should be used exclusively for perchloric acid applications to minimize possible fire and explosion.

**Radioisotope Fume Hoods** are designed to handle radioactive isotopes. All corners are welded and coved for ease of cleaning. Work surface is reinforced to handle heavy loads within the hood.

**Distillation Fume Hoods** are designed for tall apparatus such as distillation towers, etc.

**Floor-Mounted Fume Hoods** are designed for tall or large apparatus. They also allow roll-in equipment, mobile tables or robots to be used inside the fume hood.

**Demonstration Fume Hoods** are fume hoods that are accessible from either the front or back sides. They are generally used for demonstration purposes. Often these fume hoods are equipped with a side view window for instructor supervision.

**Hydrofluoric Acid Fume Hoods** are available. Please contact Mott Manufacturing for ordering information.

*FUME HOODS  
OVERVIEW*

Fume Hood Introduction

**Standard Pro Fume Hood Features**

- 18 ga exterior front by-pass grill and side panels.
- 16 ga 316 stainless steel air foil with electrical cord notch at both ends .
- Sash 7/32" thick laminated safety glass .
- Sash guides 316 stainless steel running in a corrosion resistant polyvinyl chloride (PVC) track.
- Sash suspension ether:
  - Single stainless steel 3/32" stranded cable
  - #35 steel chain (see note A)
- Pulley assembly for sash cable: 1-1/2" diameter nylon roller with steel ball bearing and cable retaining device and a single counter weight.
- Drive assembly for sash chain is 3" diameter steel sprockets on a full width 1/2" diameter drive shaft and a single counter weight . (see note A) Sash pull of 18 ga 316 stainless steel with a #4 finish.
- Interior access panels on both sides, and secured using molded vinyl gasket designed to be removed and reinstalled without use of special tools.
- Non metallic baffle support.
- No exposed interior or exterior metallic screws or fasteners.
- Duct stubs: bell shaped, round type 316 stainless steel, 18 ga or rectangular type 316 stainless steel, 18 ga.
- UL1805 classified.
- CSA certified.
- Optional factory pre-plumbing as per customer specifications.
- .375" OD copper tubing for all services.
- .375" schedule 40 black pipe for natural gas in USA only.

Ⓐ Not available on Demonstration fume hoods or Observation hoods.



*FUME HOODS  
DETAILS*

**Typical Rough in Details**

These dimensions apply to all fume hoods unless otherwise noted on the specific fume hood page

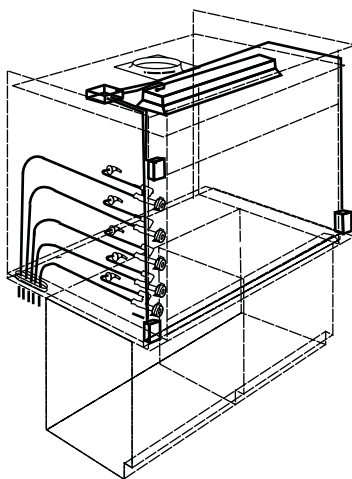
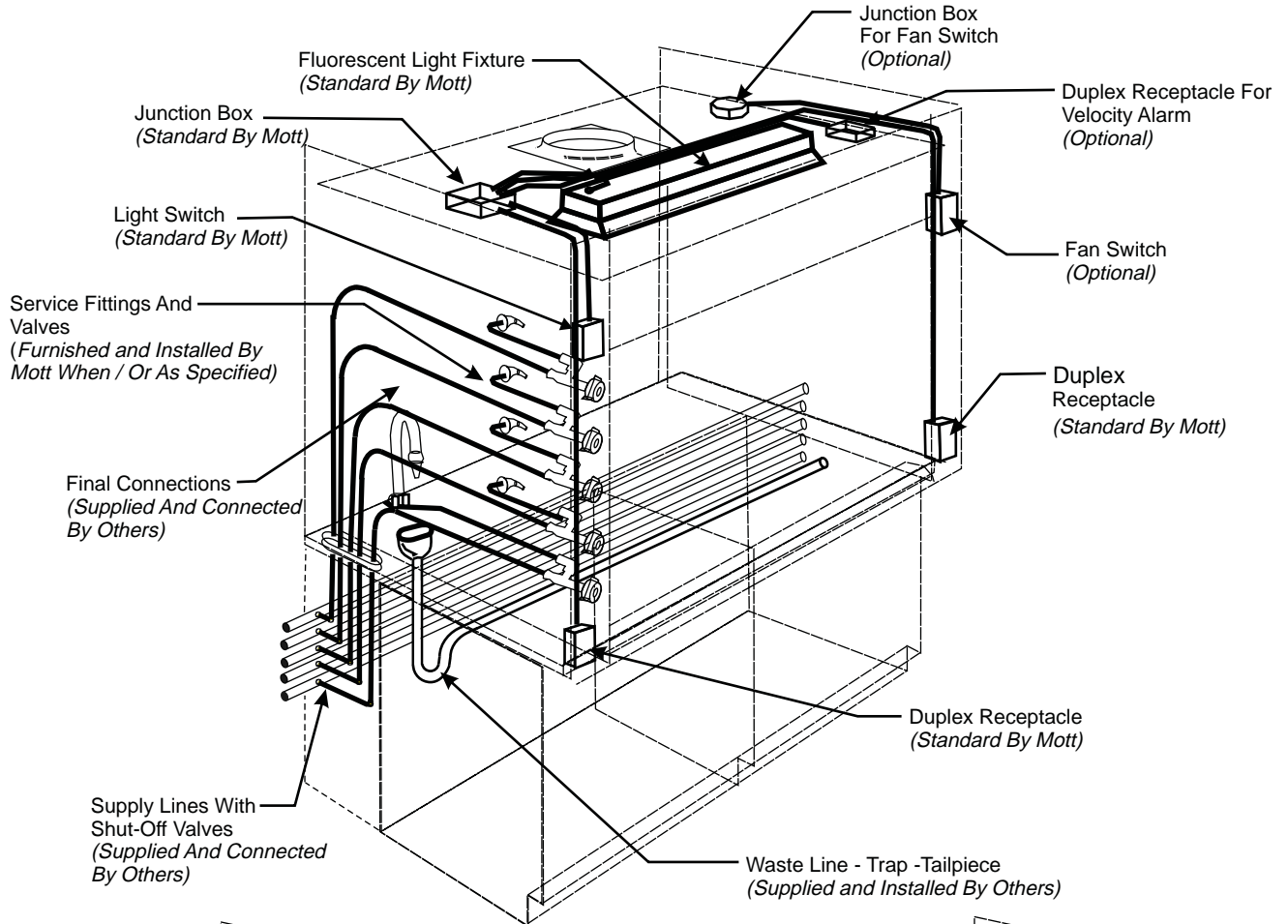

**TYPICAL HOOD WITH PLUMBING  
PRE-PIPED DOWN TO BOTTOM**

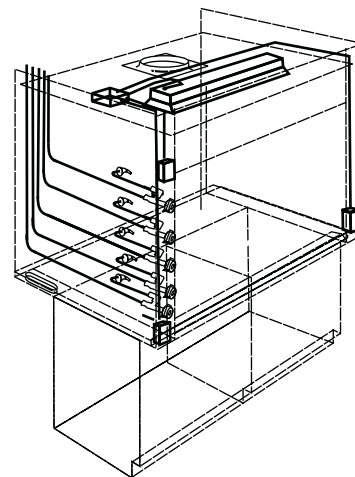

**TYPICAL HOOD WITH PLUMBING  
PRE-PIPED UP TO TOP**

*FUME HOODS  
DETAILS*

**Typical Rough in Details**

These dimensions apply to all fume hoods unless otherwise noted on the specific fume hood page

TYPICAL FUME HOOD WIRING DIAGRAM  
SHOWING OPTIONAL FAN SWITCH AND  
VELOCITY ALARM DUPLEX.

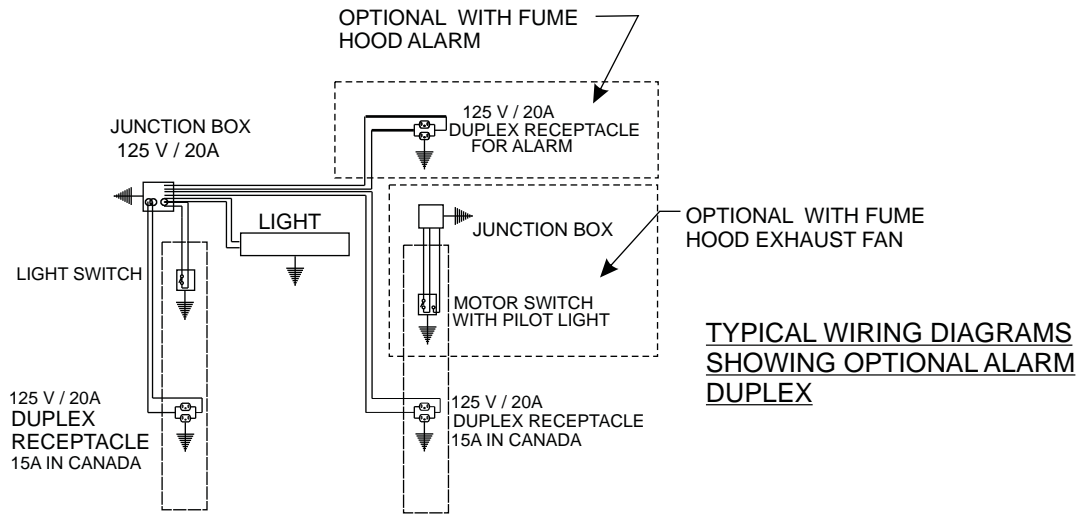

*FUME HOODS  
DETAILS*

**Typical Roof Details**

These dimensions apply to all fume hoods unless otherwise noted on the specific fume hood page

**Pro Bench and Floor-Mounted Fume Hood (typical)**

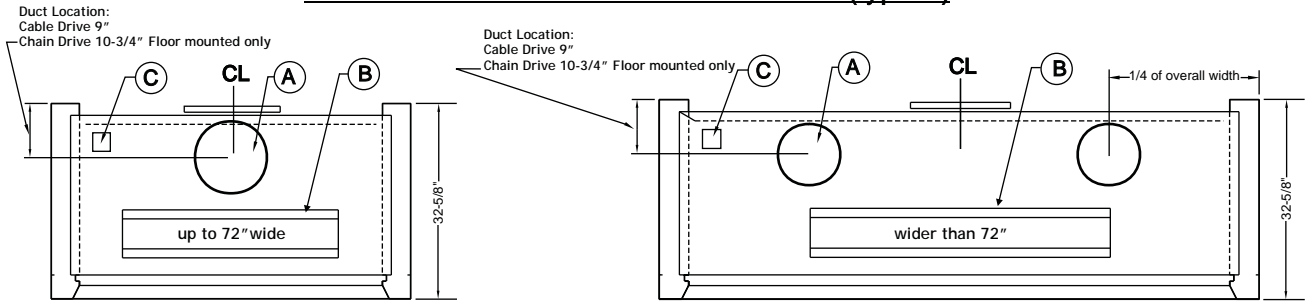

**Pro Auxiliary Air Fume Hood (typical)**

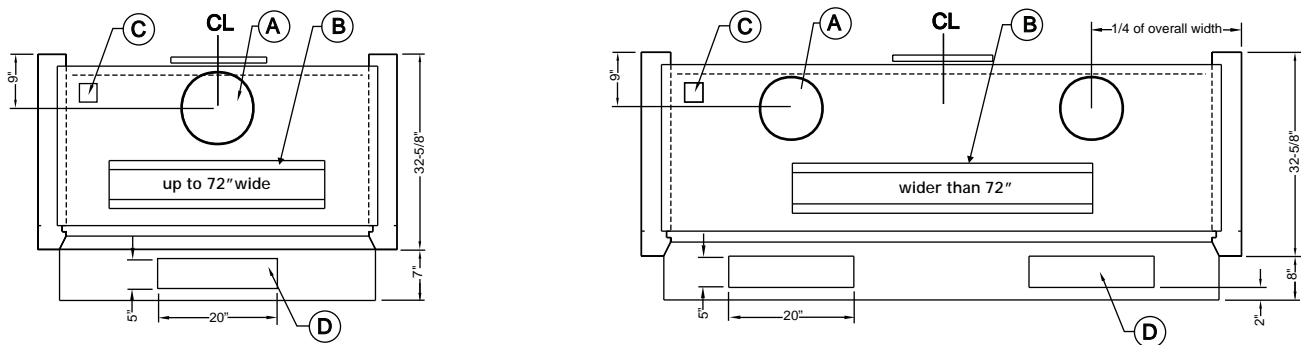

**Fully Accessible Fume Hood -39 1/4 deep (typical)**

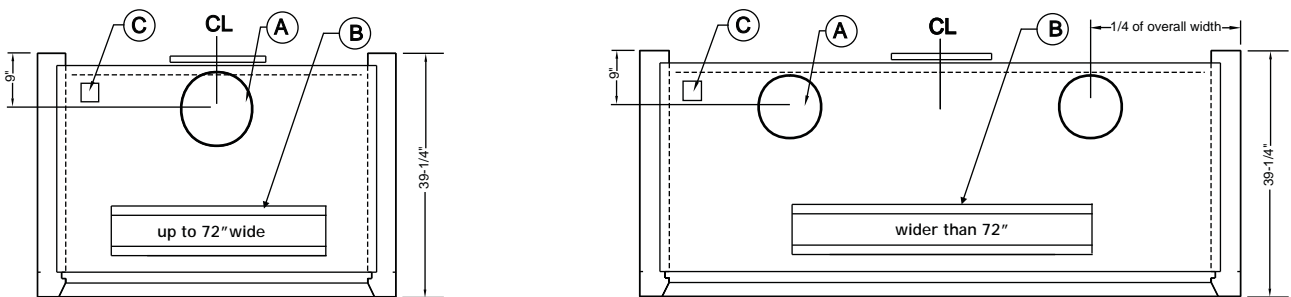

**Pro Split Sash Fume Hood (typical)**

**ITEMS:**

- (A) Exhaust duct stub - see exhaust parameter tables
- (B) Fluorescent light fixture
- (C) Electrical Junction Box
- (D) Supply air duct stub (Auxiliary air only)

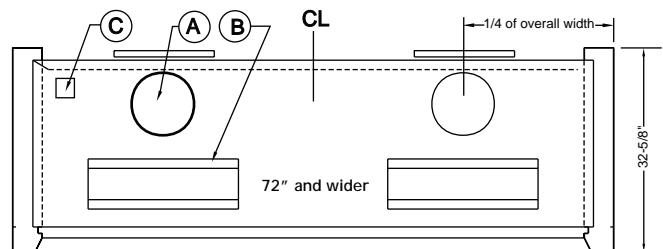

*FUME HOODS  
DETAILS*

**Typical Roof Details**

These dimensions apply to all fume hoods unless otherwise noted on the specific fume hood page

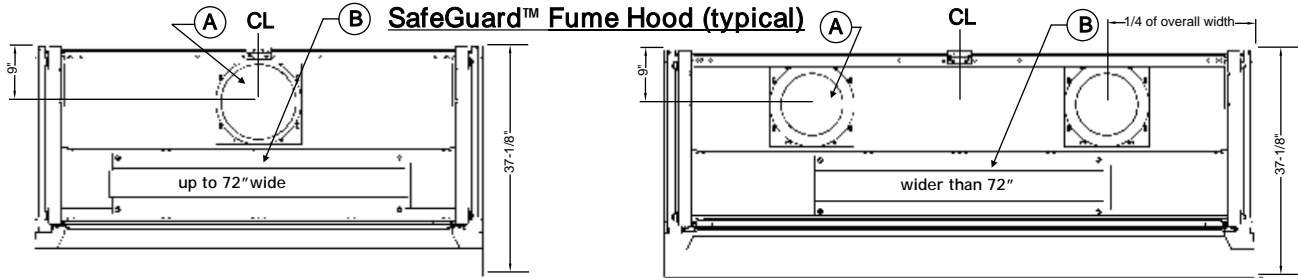

**RFV2™ Bench Fume Hood (typical)**

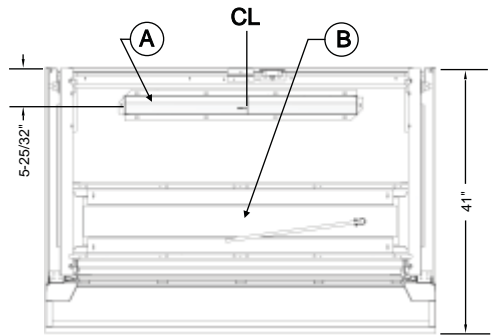

**Items**

- Ⓐ Exhaust duct stub - see exhaust parameter tables
- Ⓑ Fluorescent light fixture

**Observation™ Bench Fume Hood (typical)**

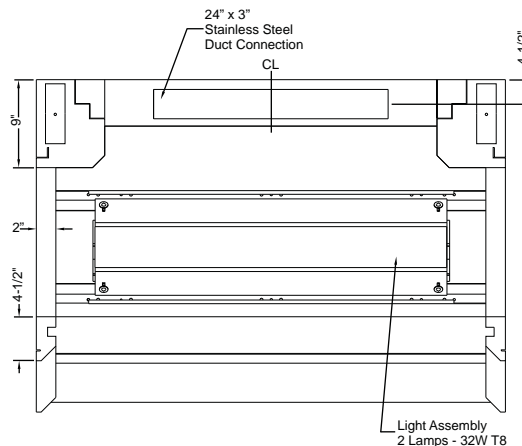

*FUME HOODS  
DETAILS*

**Typical Roof Details**

These dimensions apply to all fume hoods unless otherwise noted on the specific fume hood page  
Observation™ Constant Volume Island Bench Fume Hood (typical)

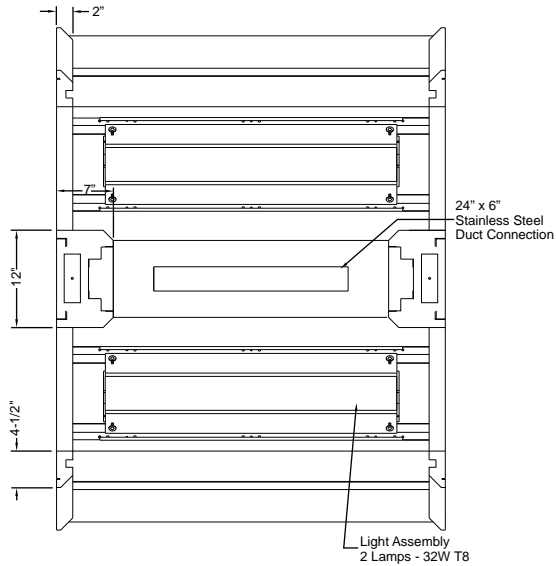

Observation™ Variable Air Volume Island Bench Fume Hood (typical)

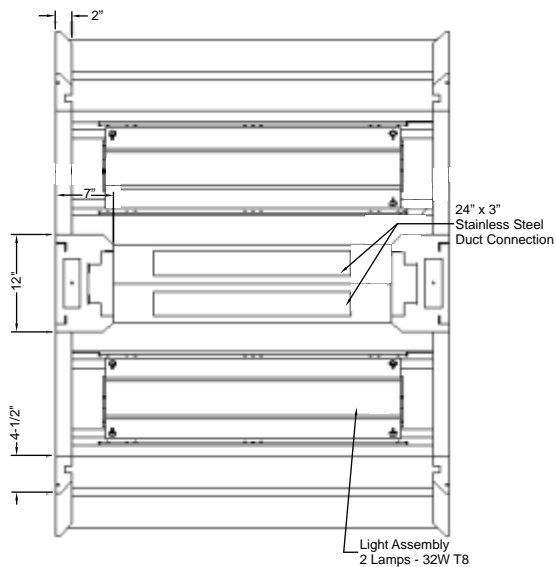

*FUME HOODS*  
*OBSERVATION2™ DETAILS*

**Typical Roof Details**

These dimensions apply to all fume hoods unless otherwise noted on the specific fume hood page

**Observation2™ Constant Volume  
Double-Faced Bench Fume Hood (typical)**

**Observation2™ Variable Air Volume  
Double-Faced Bench Fume Hood (typical)**

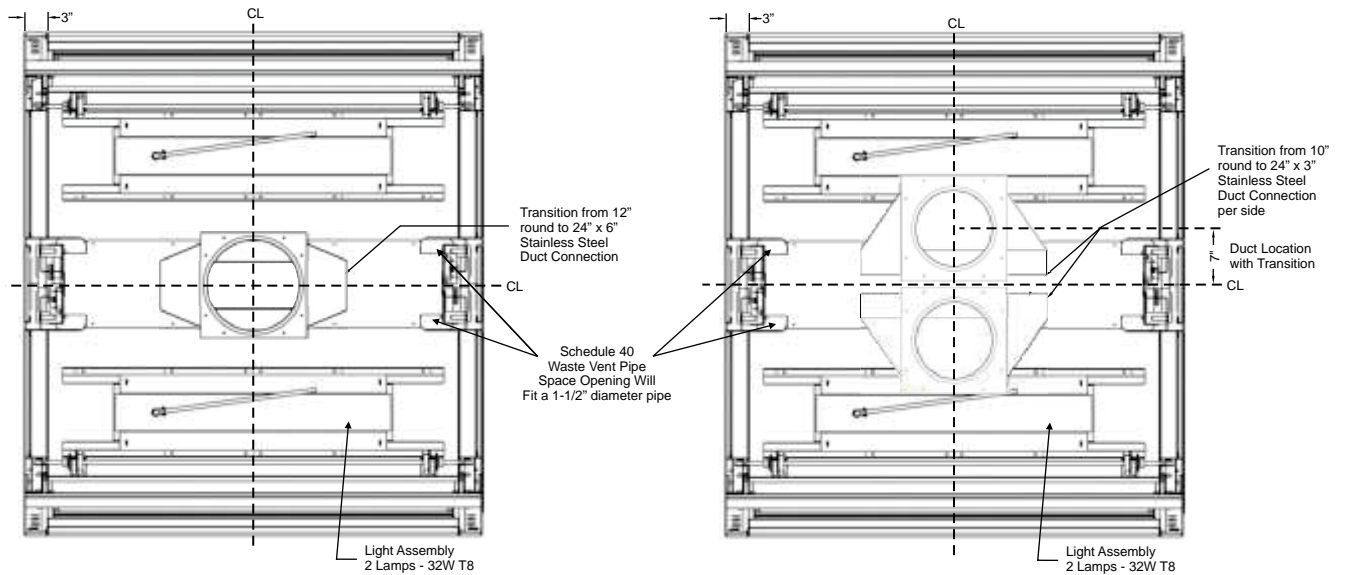

**Observation2™ Constant Volume & Variable Air Volume  
Single-Faced Bench Fume Hood (typical)**

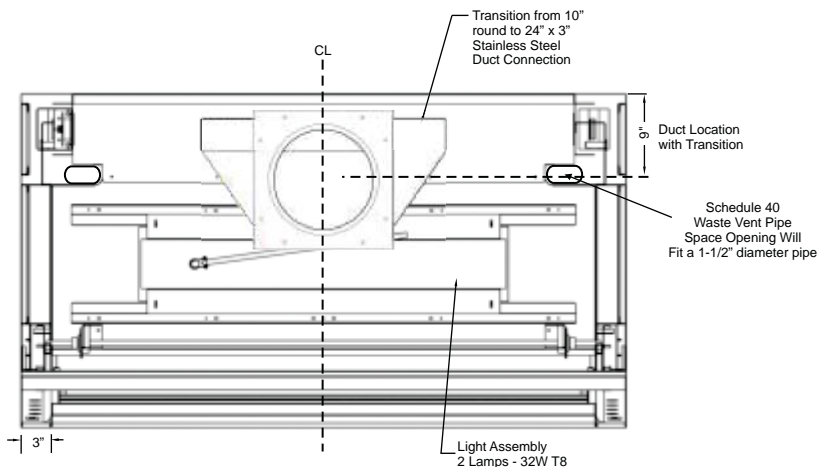

*Fume Hood Details*

**Typical Optima™ Fume Hood Roof Details**

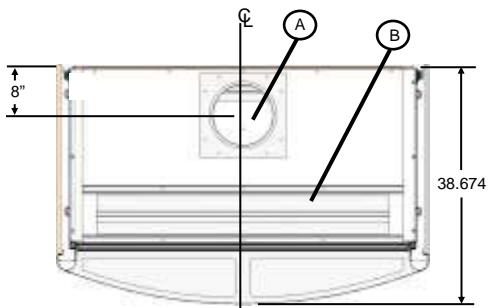

Items

- Ⓐ Exhaust duct stub - see exhaust parameter tables
- Ⓑ Fluorescent light fixture

**Optima™ Dimensions - End View**

**ADA Fixture Location - End View**

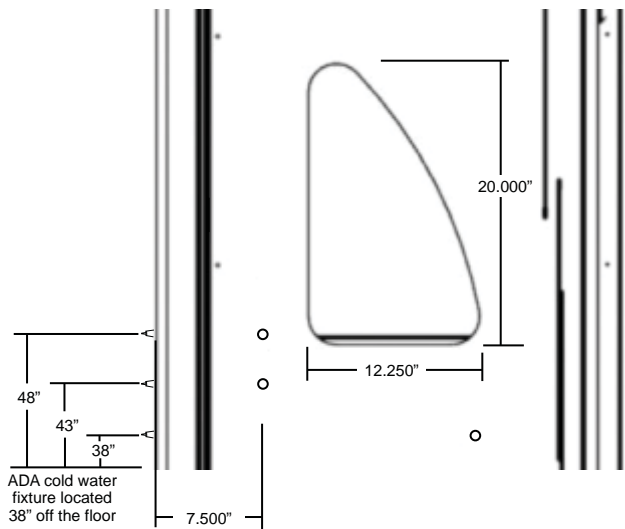
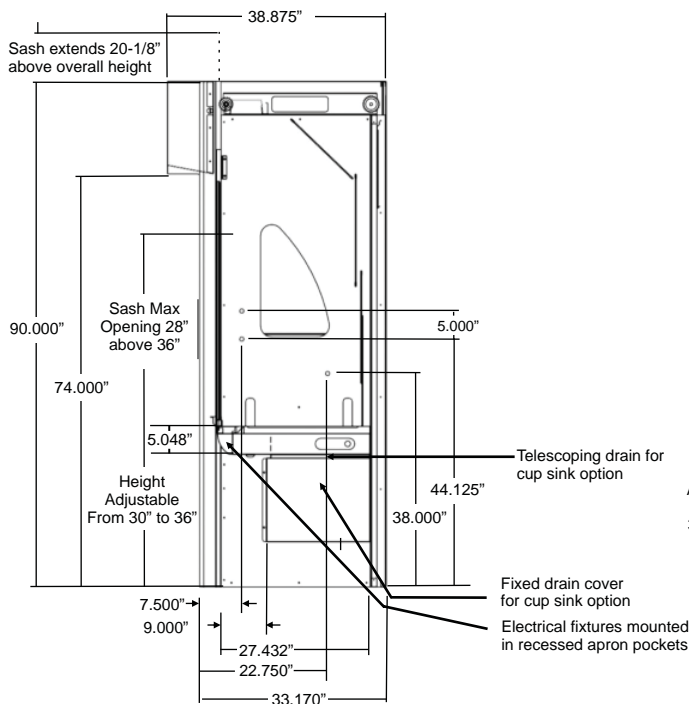

NOTE: Standard fixture location (not ADA) is 39- 3/4" off the floor and are spaced 5" apart for standard applications.

**Optima™ Work Top Dimensions Shown With Optional Cup Sink Location**

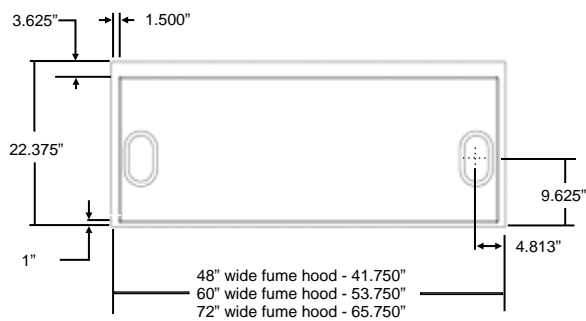



*FUME HOODS  
PRO BENCH - VERTICAL SASH*

**Features**

This all purpose fume hood is designed to meet most laboratory Constant Air Volume (CAV) or Variable Air Volume (VAV) requirements. For VAV use add option S2. Designed to mount on a 30" deep counter top. The Pro bench mounted fume hood is supplied with the following standard features:



- A vertical rising sash.
- An automatic compensating upper by-pass.
- Field-convertible to Restricted By-Pass for VAV use. Add option code S2 for Restricted by-pass plate.
- A lower airfoil by-pass with electrical cord notches.
- CSA Certified and UL Classified.
- A UL/CSA approved fluorescent light fixture complete with bulbs that provide a minimum work surface luminescence of 80 foot candles and a corner post mounted UL/CSA approved switch.
- Two UL/CSA approved duplex receptacles for 120 volt service - one receptacle on each corner post.
- Both corner posts pre-punched to accept a maximum of 5 plumbing fittings per post.
- Removable interior access panel in each side wall.
- Removable exterior side panels.
- Several liner materials are available.
- Available in either stainless steel cable, or chain and sprocket sash suspension system.
- Fume hoods with type 316 stainless steel radiused corner interiors are manufactured with an integral stainless steel wood core top.

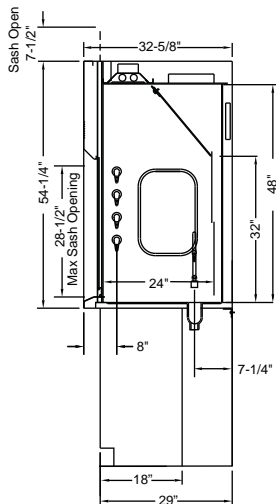

VERTICAL RAISING SASH (Cable Sash System)					
Width	FRP	PVC	Epoxy	316 S/S Sq. Cor	316 S/S Rad. Cor
36"	7121000	7123000	7126000	7124000	7125000
48"	7221000	7223000	7226000	7224000	7225000
60"	7321000	7323000	7326000	7324000	7325000
72"	7421000	7423000	7426000	7424000	7425000
96"	7521000	7523000	7526000	7524000	7525000
1000mm	7B21000	7B23000	7B26000	7B24000	7B25000
1513mm	7C21000	7C23000	7C26000	7C24000	7C25000
2000mm	7D21000	7D23000	7D26000	7D24000	7D25000

VERTICAL RAISING SASH (Chain & Sprocket Sash System)					
Width	FRP	PVC	Epoxy	316 S/S Sq. Cor	316 S/S Rad. Cor
36"	7121040	7123040	7126040	7124040	7125040
48"	7221040	7223040	7226040	7224040	7225040
60"	7321040	7323040	7326040	7324040	7325040
72"	7421040	7423040	7426040	7424040	7425040
96"	7521040	7523040	7526040	7524040	7525040
1000mm	7B21040	7B23040	7B26040	7B24040	7B25040
1513mm	7C21040	7C23040	7C26040	7C24040	7C25040
2000mm	7D21040	7D23040	7D26040	7D24040	7D25040

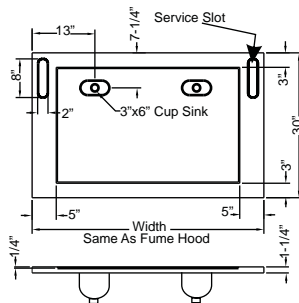

Typical fume hood work top showing optional cup sinks located for 18" deep cabinets. Cup sink location suits a gooseneck only.

Exhaust Parameters		80 FPM		100 FPM		80 FPM		100 FPM	
		28-1/2 Max Sash Opening		28-1/2 Max Sash Opening		18 Max Sash Opening		18 Max Sash Opening	
Hood Size	Duct Dia.	CFM	SP	CFM	SP	CFM	SP	CFM	SP
36"	10"	434	0.05	543	0.10	280	0.03	350	0.04
48"	10"	630	0.15	789	0.20	407	0.06	508	0.09
60"	12"	830	0.15	1035	0.20	533	0.05	667	0.07
72"	12"	1025	0.20	1280	0.25	660	0.07	825	0.11
96"	2@10"	1418	0.20	1772	0.25	913	0.07	1142	0.11
1000mm	10"	490	0.10	612	0.15	316	0.04	395	0.05
1513mm	12"	820	0.15	1025	0.20	528	0.05	660	0.07
2000mm	12"	1135	0.20	1419	0.30	731	0.09	914	0.14

*FUME HOODS*  
*PRO RESTRICTED BY-PASS BENCH - VERTICAL SASH*

**Features**

This all purpose fume hood is designed to meet most laboratory Variable Air Volume (VAV) requirements. Designed to mount on a 30" deep counter top.

The Pro bench mounted fume hood is supplied with the following standard features:

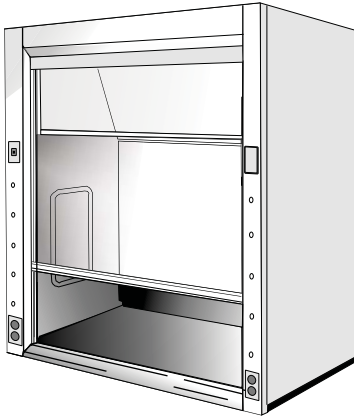

- Restricted by-pass is standard.
- A full view vertical rising sash.
- Restricted upper by-pass is standard.
- A lower airfoil by-pass with electrical cord notches.
- CSA Certified and UL Classified.
- A UL/CSA approved fluorescent light fixture complete with bulbs that provide a minimum work surface luminescence of 80 foot candles and a corner post mounted UL/CSA approved switch.
- Two UL/CSA approved duplex receptacles for 120 volt service - one receptacle on each corner post.
- Both corner posts pre-punched to accept a maximum of 5 plumbing fittings per post.
- Removable interior access panel in each side wall.
- Removable exterior side panels.
- Several liner materials are available.
- Available in either stainless steel cable, or chain and sprocket sash suspension system.
- Fume hoods with type 316 stainless steel radiused corner interiors are manufactured with an integral stainless steel wood core top.

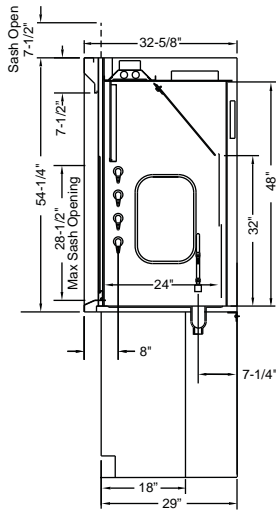

VERTICAL RAISING SASH (Cable sash system)					
Width	FRP	PVC	Epoxy	316 S/S Sq. Cor	316 S/S Rad. Cor
36"	7151000	7153000	7156000	7154000	7155000
48"	7251000	7253000	7256000	7254000	7255000
60"	7351000	7353000	7356000	7354000	7355000
72"	7451000	7453000	7456000	7454000	7455000
96"	7551000	7553000	7556000	7554000	7555000
1000mm	7B51000	7B53000	7B56000	7B54000	7B55000
1513mm	7C51000	7C53000	7C56000	7C54000	7C55000
2000mm	7D51000	7D53000	7D56000	7D54000	7D55000

VERTICAL RAISING SASH (Chain & Sprocket sash system)					
Width	FRP	PVC	Epoxy	316 S/S Sq. Cor	316 S/S Rad. Cor
36"	7151040	7153040	7156040	7154040	7155040
48"	7251040	7253040	7256040	7254040	7255040
60"	7351040	7353040	7356040	7354040	7355040
72"	7451040	7453040	7456040	7454040	7455040
96"	7551040	7553040	7556040	7554040	7555040
1000mm	7B51040	7B53040	7B56040	7B54040	7B55040
1513mm	7C51040	7C53040	7C56040	7C54040	7C55040
2000mm	7D51040	7D53040	7D56040	7D54040	7D55040

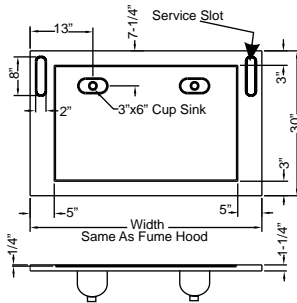

Typical fume hood work top showing optional cup sinks located for 18" deep cabinets.  
Cup sink location suits a gooseneck only.

Exhaust Parameters		80 FPM		100 FPM		80 FPM		100 FPM	
		28-1/2 Max Sash Opening		28-1/2 Max Sash Opening		18 Max Sash Opening		18 Max Sash Opening	
Hood Size	Duct Dia.	CFM	SP	CFM	SP	CFM	SP	CFM	SP
36"	10"	434	0.05	543	0.10	280	0.03	350	0.04
48"	10"	630	0.15	789	0.20	407	0.06	508	0.09
60"	12"	830	0.15	1035	0.20	533	0.05	667	0.07
72"	12"	1025	0.20	1280	0.25	660	0.07	825	0.11
96"	2@10"	1418	0.20	1772	0.25	913	0.07	1142	0.11
1000mm	10"	490	0.10	612	0.15	316	0.04	395	0.05
1513mm	12"	820	0.15	1025	0.20	528	0.05	660	0.07
2000mm	12"	1135	0.20	1419	0.30	731	0.09	914	0.14

*FUME HOODS  
PRO BENCH - COMBINATION SASH*

**Features**

This all purpose fume hood is designed to meet most laboratory Variable Air Volume (VAV) requirements. Designed to mount on a 30" deep counter top.

The Pro bench mounted fume hood is supplied with the following standard features:



- Restricted upper by-pass is standard.
- Combination vertical rising and horizontal sliding sash on PVC track.
- A lower airfoil by-pass with electrical cord notches.
- CSA Certified and UL Classified.
- A UL/CSA approved fluorescent light fixture complete with bulbs that provide a minimum work surface luminescence of 80 foot candles and a corner post mounted UL/CSA approved switch.
- Two UL/CSA approved duplex receptacles for 120 volt service - one receptacle on each corner post.
- Both corner posts pre-punched to accept a maximum of 5 plumbing fittings per post.
- Removable interior access panel in each side wall.
- Removable exterior side panels.
- Several liner materials are available.
- Available in either stainless steel cable, or chain and sprocket sash suspension system.
- Fume hoods with type 316 stainless steel radiused corner interiors are manufactured with an integral stainless steel wood core top.

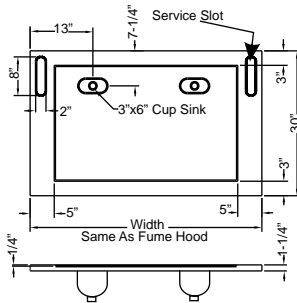
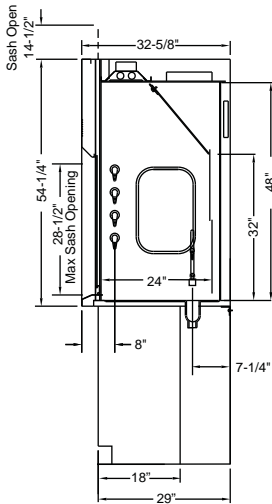

Typical fume hood work top showing optional cup sinks located for 18" deep cabinets.  
Cup sink location suits a gooseneck only.

Horizontal Panels On Combo Sash Hood		
Hood Width	Sash Width	# of Panels
48"	9-3/4"	4
60"	12-3/4"	4
72"	15-3/4"	4
96"	14-13/16"	6

COMBINATION SASH (Cable sash system)					
Width	FRP	PVC	Epoxy	316 S/S Sq. Cor	316 S/S Rad. Cor
48"	7221010	7223010	7226010	7224010	7225010
60"	7321010	7323010	7326010	7324010	7325010
72"	7421010	7423010	7426010	7424010	7425010
96"	7521010	7523010	7526010	7524010	7525010
1513mm	7C21010	7C23010	7C26010	7C24010	7C25010
2000mm	7D21010	7D23010	7D26010	7D24010	7D25010

COMBINATION SASH (Chain & Sprocket sash system)					
Width	FRP	PVC	Epoxy	316 S/S Sq. Cor	316 S/S Rad. Cor
48"	7221050	7223050	7226050	7224050	7225050
60"	7321050	7323050	7326050	7324050	7325050
72"	7421050	7423050	7426050	7424050	7425050
96"	7521050	7523050	7526050	7524050	7525050
1513mm	7C21050	7C23050	7C26050	7C24050	7C25050
2000mm	7D21050	7D23050	7D26050	7D24050	7D25050

Exhaust Parameters		80 FPM		100 FPM		80 FPM		100 FPM	
		1/2 Sliding Door Open		1/2 Sliding Door Open		18 Max Sash Opening		18 Max Sash Opening	
Hood Size	Duct Dia.	CFM	SP	CFM	SP	CFM	SP	CFM	SP
48"	10"	315	0.05	394	0.05	407	0.06	508	0.09
60"	12"	414	0.05	517	0.05	533	0.05	667	0.07
72"	12"	512	0.05	640	0.10	660	0.07	825	0.11
96"	2@10"	709	0.05	886	0.10	913	0.07	1142	0.11
1513mm	12"	410	0.05	513	0.10	528	0.05	660	0.07
2000mm	12"	567	0.05	709	0.10	731	0.09	914	0.14

*FUME HOODS*  
**PRO CONSTANT VOLUME BENCH - SPLIT SASH/POSTLESS**

**Features**

This all purpose fume hood is designed to meet most laboratory Constant Air Volume (CAV) or Variable Air Volume (VAV) requirements. For VAV use add option S2. Designed to mount on a 30" deep counter top. The Pro bench mounted fume hood is supplied with the following standard features:

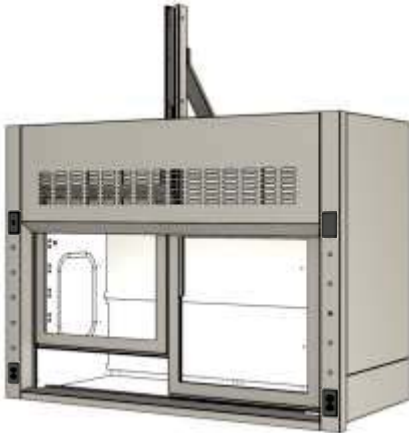

- Two independently operated vertical rising sashes.
- An automatic compensating upper by-pass .
- Add option code S2 for an optional restricted by-pass damper.
- A lower airfoil by-pass with electrical cord notches.
- CSA Certified and UL Classified.
- A UL/CSA approved fluorescent light fixture complete with bulbs that provide a minimum work surface luminescence of 80 foot candles and a corner post mounted UL/CSA approved switch.
- Two UL/CSA approved duplex receptacles for 120 volt service - one receptacle on each corner post.
- Both corner posts pre-punched to accept a maximum of 5 plumbing fittings per post.
- Removable interior access panel in each side wall.
- Removable exterior side panels.
- Several liner materials are available.
- Fume hoods with type 316 stainless steel radiused corner interiors are manufactured with an integral stainless steel wood core top.

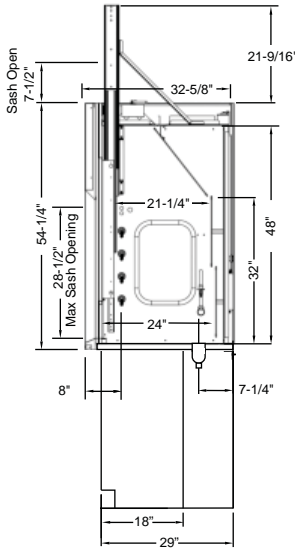

VERTICAL RAISING SPLIT POSTLESS SASH (Cable sash system)					
Width	FRP	PVC	Epoxy	316 S/S Sq. Cor	316 S/S Rad. Cor
72"	7421030	7423030	7426030	7424030	7425030
96"	7521030	7523030	7526030	7524030	7525030
120"	7621030	7623030	7626030	7624030	7625030
144"	7H21030	7H23030	7H26030	7H24030	7H25030
2000mm	7D21030	7D23030	7D26030	7D24030	7D25030

VERTICAL RAISING SPLIT POSTLESS SASH (Chain & Sprocket sash system)					
Width	FRP	PVC	Epoxy	316 S/S Sq. Cor	316 S/S Rad. Cor
96"	7521080	7523080	7526080	7524080	7525080
120"	7621080	7623080	7626080	7624080	7625080
144"	7H21080	7H23080	7H26080	7H24080	7H25080
2000mm	7D21080	7D23080	7D26080	7D24080	7D25080

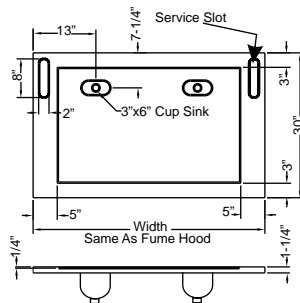

Typical fume hood work top showing optional cup sinks located for 18" deep cabinets. Cup sink location suits a gooseneck only.

Exhaust Parameters		80 FPM		100 FPM		80 FPM		100 FPM	
		28-1/2 Max Sash Opening		28-1/2 Max Sash Opening		18 Max Sash Opening		18 Max Sash Opening	
Hood Size	Duct Dia.	CFM	SP	CFM	SP	CFM	SP	CFM	SP
72"	2@10"	1025	0.10	1280	0.15	660	0.05	825	0.06
96"	2@10"	1418	0.20	1772	0.25	913	0.07	1142	0.11
120"	2@12"	1811	0.15	2264	0.20	1167	0.06	1458	0.09
144"	2@12"	2205	0.20	2755	0.30	1420	0.08	1775	0.13
2000mm	2@10"	1135	0.11	1419	0.17	731	0.05	914	0.07

*FUME HOODS*  
*PRO RESTRICTED BY-PASS BENCH - VERTICAL SASH*

**Features**

This all purpose fume hood is designed to meet most laboratory Variable Air Volume (VAV) requirements. Designed to mount on a 30" deep counter top.

The Pro bench mounted fume hood is supplied with the following standard features:



- A vertical rising sash.
- Restricted upper by-pass is standard.
- A lower airfoil by-pass with electrical cord notches.
- CSA Certified and UL Classified.
- A UL/CSA approved fluorescent light fixture complete with bulbs that provide a minimum work surface luminescence of 80 foot candles and a corner post mounted UL/CSA approved switch.
- Two UL/CSA approved duplex receptacles for 120 volt service - one receptacle on each corner post.
- Both corner posts pre-punched to accept a maximum of 5 plumbing fittings per post.
- Removable interior access panel in each side wall.
- Removable exterior side panels.
- Fume hoods with type 316 stainless steel radiused corner interiors are manufactured with an integral stainless steel wood core top.

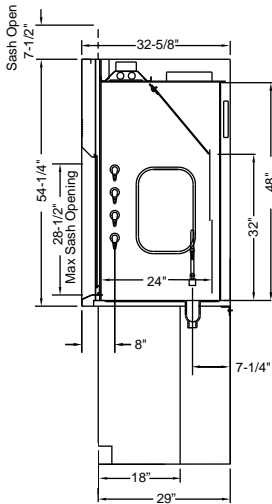

VERTICAL RAISING SASH (Cable sash system)					
Width	FRP	PVC	Epoxy	316 S/S Sq. Cor	316 S/S Rad. Cor
36"	7121000-S2	7123000-S2	7126000-S2	7124000-S2	7125000-S2
48"	7221000-S2	7223000-S2	7226000-S2	7224000-S2	7225000-S2
60"	7321000-S2	7323000-S2	7326000-S2	7324000-S2	7325000-S2
72"	7421000-S2	7423000-S2	7426000-S2	7424000-S2	7425000-S2
96"	7521000-S2	7523000-S2	7526000-S2	7524000-S2	7525000-S2
1000mm	7B21000-S2	7B23000-S2	7B26000-S2	7B24000-S2	7B25000-S2
1513mm	7C21000-S2	7C23000-S2	7C26000-S2	7C24000-S2	7C25000-S2
2000mm	7D21000-S2	7D23000-S2	7D26000-S2	7D24000-S2	7D25000-S2

VERTICAL RAISING SASH (Chain & Sprocket sash system)					
Width	FRP	PVC	Epoxy	316 S/S Sq. Cor	316 S/S Rad. Cor
36"	7121040-S2	7123040-S2	7126040-S2	7124040-S2	7125040-S2
48"	7221040-S2	7223040-S2	7226040-S2	7224040-S2	7225040-S2
60"	7321040-S2	7323040-S2	7326040-S2	7324040-S2	7325040-S2
72"	7421040-S2	7423040-S2	7426040-S2	7424040-S2	7425040-S2
96"	7521040-S2	7523040-S2	7526040-S2	7524040-S2	7525040-S2
1000mm	7B21040-S2	7B23040-S2	7B26040-S2	7B24040-S2	7B25040-S2
1513mm	7C21040-S2	7C23040-S2	7C26040-S2	7C24040-S2	7C25040-S2
2000mm	7D21040-S2	7D23040-S2	7D26040-S2	7D24040-S2	7D25040-S2

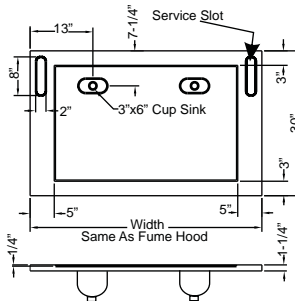

Typical fume hood work top showing optional cup sinks located for 18" deep cabinets.  
Cup sink location suits a gooseneck only.

Exhaust Parameters		80 FPM		100 FPM		80 FPM		100 FPM	
		28-1/2 Max Sash Opening		28-1/2 Max Sash Opening		18 Max Sash Opening		18 Max Sash Opening	
Hood Size	Duct Dia.	CFM	SP	CFM	SP	CFM	SP	CFM	SP
36"	10"	434	0.05	543	0.10	280	0.03	350	0.04
48"	10"	630	0.15	789	0.20	407	0.06	508	0.09
60"	12"	830	0.15	1035	0.20	533	0.05	667	0.07
72"	12"	1025	0.20	1280	0.25	660	0.07	825	0.11
96"	2@10"	1418	0.20	1772	0.25	913	0.07	1142	0.11
1000mm	10"	490	0.10	612	0.15	316	0.04	395	0.05
1513mm	12"	820	0.15	1025	0.20	528	0.05	660	0.07
2000mm	12"	1135	0.20	1419	0.30	731	0.09	914	0.14



**FUME HOODS**  
**LOW VOLUME BENCH - COMBINATION SASH**

**Features**

This low flow hood design is based upon *Safety, Economy and Simplicity*. The design concept incorporates a standard by-pass fume hood fitted with a restricted by-pass panel, a combination horizontal/vertical sash with lock down mechanism and a front mounted safety glass shield all which reduces air (energy) consumption by approximately 75%. Designed to be used on a Low Constant Volume (LCV) systems and designed to mount on a 30" deep counter top. The Pro bench mounted fume hood is supplied with the following standard features:



- A combination horizontal/vertical rising sash with keyed lock down mechanism.
- Restricted upper by-pass plate is standard.
- Laminated safety glass shield integral to the sash.
- Airflow is maintained within the ANSI and OSHA recommendations of 80 and 100 feet per minuted face velocity.
- Air (energy) consumption can be reduced by approximately 75%.
- A lower airfoil by-pass with electrical cord notches.
- CSA Certified and UL Classified.
- A UL/CSA approved fluorescent light fixture complete with bulbs that provide a minimum work surface luminescence of 80 foot candles and a corner post mounted UL/CSA approved switch.
- Two UL/CSA approved duplex receptacles for 120 volt service - one receptacle on each corner post.
- Both corner posts pre-punched to accept a maximum of 5 plumbing fittings per post.
- Removable interior access panel in each side wall with removable exterior side panels.
- Fume hoods with type 316 stainless steel radiused corner interiors are manufactured with an integral stainless steel wood core top.

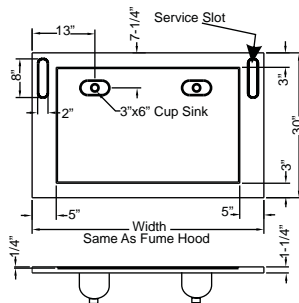
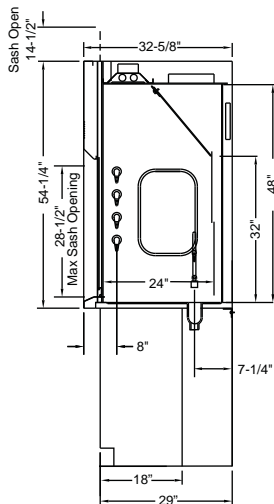

Typical fume hood work top showing optional cup sinks located for 18" deep cabinets.  
Cup sink location suits a gooseneck only.

COMBINATION SASH (Cable sash system)					
Width	FRP	PVC	Epoxy	316 S/S Sq. Cor	316 S/S Rad. Cor
36"	7121010-LV	7123010-LV	7126010-LV	7124010-LV	7125010-LV
48"	7221010-LV	7223010-LV	7226010-LV	7224010-LV	7225010-LV
60"	7321010-LV	7323010-LV	7326010-LV	7324010-LV	7325010-LV
72"	7421010-LV	7423010-LV	7426010-LV	7424010-LV	7425010-LV
96"	7521010-LV	7523010-LV	7526010-LV	7524010-LV	7525010-LV
1000mm	7B21010-LV	7B23010-LV	7B26010-LV	7B24010-LV	7B25010-LV
1513mm	7C21010-LV	7C23010-LV	7C26010-LV	7C24010-LV	7C25010-LV
2000mm	7D21010-LV	7D23010-LV	7D26010-LV	7D24010-LV	7D25010-LV

COMBINATION SASH (Chain & Sprocket sash system)					
Width	FRP	PVC	Epoxy	316 S/S Sq. Cor	316 S/S Rad. Cor
36"	7121050-LV	7123050-LV	7126050-LV	7124050-LV	7125050-LV
48"	7221050-LV	7223050-LV	7226050-LV	7224050-LV	7225050-LV
60"	7321050-LV	7323050-LV	7326050-LV	7324050-LV	7325050-LV
72"	7421050-LV	7423050-LV	7426050-LV	7424050-LV	7425050-LV
96"	7521050-LV	7523050-LV	7526050-LV	7524050-LV	7525050-LV
1000mm	7B21050-LV	7B23050-LV	7B26050-LV	7B24050-LV	7B25050-LV
1513mm	7C21050-LV	7C23050-LV	7C26050-LV	7C24050-LV	7C25050-LV
2000mm	7D21050-LV	7D23050-LV	7D26050-LV	7D24050-LV	7D25050-LV

Exhaust Parameters		100 FPM	
		Working Position Sash (Locked Down)	
Hood Size	Duct Dia.	CFM	SP
48"	10"	190	0.02
60"	12"	260	0.02
72"	12"	330	0.02
96"	2 @ 10"	472	0.02
1000mm	10"	160	0.02
1513mm	12"	266	0.02
2000mm	12"	369	0.02

**Note:** Face velocities as low as 80 FPM will provide containment. However, NFPA minimum volume will not be met, therefore 100 FPM data only is provided.

Horizontal Panels On Combo Sash Hood		
Hood Width	Sash Width	# of Panels
48"	9-3/4"	4
60"	12-3/4"	4
72"	15-3/4"	4
96"	14-13/16"	6

*FUME HOODS*  
*PRO AUXILIARY AIR BENCH - VERTICAL SASH*

**Features**

This all purpose fume hood is designed to meet most laboratory Constant Air Volume (CAV) requirements. Designed to mount on a 30" deep counter top. This hood is not recommended for Variable Air Volume (VAV) use. The Pro bench mounted fume hood is supplied with the following standard features:

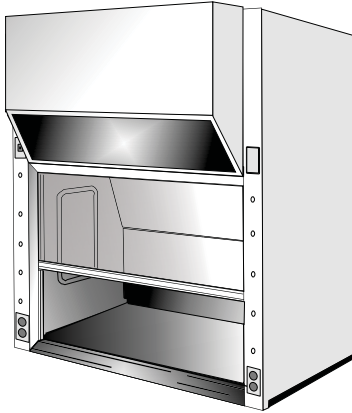

- Auxiliary air chamber above vertical raising sash.
- An automatic compensating upper by-pass.
- A lower airfoil by-pass with electrical cord notches.
- CSA Certified and UL Classified.
- A UL/CSA approved fluorescent light fixture complete with bulbs that provide a minimum work surface luminescence of 80 foot candles and a corner post mounted UL/CSA approved switch.
- Two UL/CSA approved duplex receptacles for 120 volt service - one receptacle on each corner post.
- Both corner posts pre-punched to accept a maximum of 5 plumbing fittings per post.
- Removable interior access panel in each side wall.
- Removable exterior side panels.
- Fume hoods with type 316 stainless steel radiused corner interiors are manufactured with an integral stainless steel wood core top.

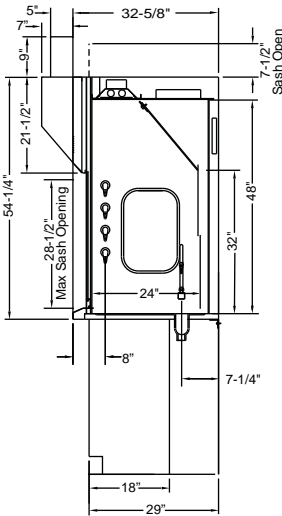

VERTICAL RAISING SASH (Cable sash system)					
Width	FRP	PVC	Epoxy	316 S/S Sq. Cor	316 S/S Rad. Cor
36"	7161000	7163000	7166000	7164000	7165000
48"	7261000	7263000	7266000	7264000	7265000
60"	7361000	7363000	7366000	7364000	7365000
72"	7461000	7463000	7466000	7464000	7465000
96"	7561000	7563000	7566000	7564000	7565000
1000mm	7B61000	7B63000	7B66000	7B64000	7B65000
1513mm	7C61000	7C63000	7C66000	7C64000	7C65000
2000mm	7D61000	7D63000	7D66000	7D64000	7D65000

VERTICAL RAISING SASH (Chain & Sprocket sash system)					
Width	FRP	PVC	Epoxy	316 S/S Sq. Cor	316 S/S Rad. Cor
36"	7161040	7163040	7166040	7164040	7165040
48"	7261040	7263040	7266040	7264040	7265040
60"	7361040	7363040	7366040	7364040	7365040
72"	7461040	7463040	7466040	7464040	7465040
96"	7561040	7563040	7566040	7564040	7565040
1000mm	7B61040	7B63040	7B66040	7B64040	7B65040
1513mm	7C61040	7C63040	7C66040	7C64040	7C65040
2000mm	7D61040	7D63040	7D66040	7D64040	7D65040

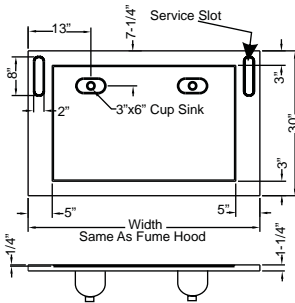

Typical fume hood work top showing optional cup sinks located for 18" deep cabinets.  
Cup sink location suits a gooseneck only.

Exhaust Parameters		80 FPM		100 FPM		Supply Air Parameters @ 100FPM		70% Make-Up	
		28-1/2 Max Sash Opening		28-1/2 Max Sash Opening		100FPM		28-1/2 Max Sash Opening	
Hood Size	Duct Dia.	CFM	SP	CFM	SP	Hood Size	Duct Dia.	CFM	SP
36"	10"	434	0.05	543	0.10	36"	5x20"	380	0.15
48"	10"	630	0.15	789	0.20	48"	5x20"	552	0.15
60"	12"	830	0.15	1035	0.20	60"	5x20"	725	0.30
72"	12"	1025	0.20	1280	0.25	72"	5x20"	896	0.35
96"	2@10"	1418	0.20	1772	0.25	96"	2@5x20"	1240	0.30
1000mm	10"	490	0.10	612	0.15	1000mm	5x20"	428	0.15
1513mm	12"	820	0.15	1025	0.20	1513mm	5x20"	718	0.30
2000mm	12"	1135	0.20	1419	0.30	2000mm	5x20"	993	0.40



*FUME HOODS*  
*PRO DISTILLATION FUME HOOD - DUAL VERTICAL SASH*

**Features**

This all purpose fume hood is designed to meet most laboratory Constant Air Volume (CAV) or Variable Air Volume (VAV) requirements. For VAV use add option S2. Designed to mount on a 30" deep counter top. The Pro bench mounted fume hood is supplied with the following standard features:

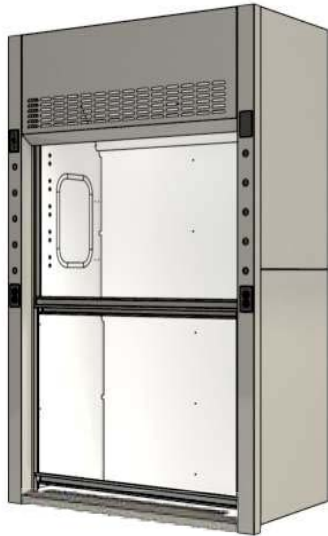

- Dual vertical rising sash.
- An automatic compensating upper by-pass.
- Add option code S2 for optional restricted by-pass damper.
- A lower airfoil by-pass with electrical cord notches.
- CSA Certified and UL Classified.
- A UL/CSA approved fluorescent light fixture complete with bulbs that provide a minimum work surface luminescence of 80 foot candles and a corner post mounted UL/CSA approved switch.
- Two UL/CSA approved duplex receptacles for 120 volt service - one receptacle on each corner post.
- Both corner posts pre-punched to accept a nominal of 5 plumbing fittings per post.
- Removable interior access panel in each side wall, two per side.
- Removable exterior side panels.
- Fume hoods with type 316 stainless steel radiused corner interiors are manufactured with an integral stainless steel wood core top.

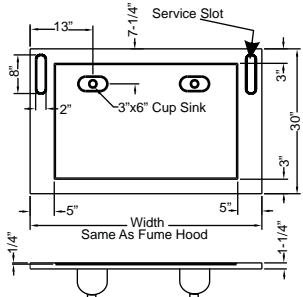
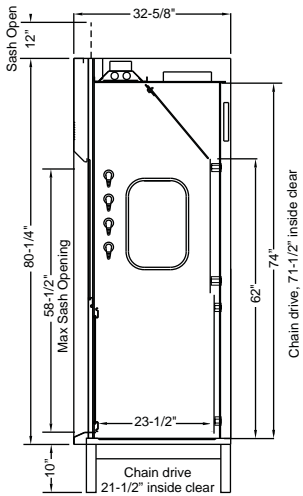

Typical fume hood work top showing optional cup sinks located for 18" deep cabinets. Cup sink location suits a gooseneck only.

VERTICAL RAISING SASH (Cable sash system)					
Width	FRP	PVC	Epoxy	316 S/S Sq. Cor	316 S/S Rad. Cor
36"	7121004	7123004	7126004	7124004	7125004
48"	7221004	7223004	7226004	7224004	7225004
60"	7321004	7323004	7326004	7324004	7325004
72"	7421004	7423004	7426004	7424004	7425004
96"	7521004	7523004	7526004	7524004	7525004
1000mm	7B21004	7B23004	7B26004	7B24004	7B25004
1513mm	7C21004	7C23004	7C26004	7C24004	7C25004
2000mm	7D21004	7D23004	7D26004	7D24004	7D25004

VERTICAL RAISING SASH (Chain & Sprocket sash system)					
Width	FRP	PVC	Epoxy	316 S/S Sq. Cor	316 S/S Rad. Cor
36"	7121044	7123044	7126044	7124044	7125044
48"	7221044	7223044	7226044	7224044	7225044
60"	7321044	7323044	7326044	7324044	7325044
72"	7421044	7423044	7426044	7424044	7425044
96"	7521044	7523044	7526044	7524044	7525044
1000mm	7B21044	7B23044	7B26044	7B24044	7B25044
1513mm	7C21044	7C23044	7C26044	7C24044	7C25044
2000mm	7D21044	7D23044	7D26044	7D24044	7D25044

Exhaust Parameters		80 FPM		100 FPM	
		28-1/2 Max Sash Opening	CFM	SP	28-1/2 Max Sash Opening
Hood Size	Duct Dia.	CFM	SP	CFM	SP
36"	10"	434	0.05	543	0.10
48"	10"	630	0.15	789	0.20
60"	12"	830	0.15	1035	0.20
72"	12"	1025	0.20	1280	0.25
96"	2@10"	1418	0.20	1772	0.25
1000mm	10"	490	0.10	612	0.15
1513mm	12"	820	0.15	1025	0.20
2000mm	12"	1135	0.20	1419	0.30

DISTILLATION TABLE	
Width	Item Number
36"	DTF1036
48"	DTF1048
60"	DTF1060
72"	DTF1072
96"	DTF1096
1000mm	DTF100B
1513mm	DTF100C
2000mm	DTF100D



- ∞ Fully welded tables are 9-3/4" high x 29" deep with 2" square tube legs and supplied with leveling glides.
- ∞ Tables larger than 48" wide are supplied with six legs (note: 48" wide unit shown).
- ∞ Tables will support an 1800lb load.
- ∞ Comes with PVC boots and levelers.

*FUME HOODS  
PRO FLOOR MOUNTED - DUAL VERTICAL SASH*

**Features**

This all purpose fume hood is designed to meet most laboratory Constant Air Volume (CAV) or Variable Air Volume (VAV) requirements. For VAV use add option S2. Designed to sit directly on laboratory floor. The Pro fume hood is supplied with the following standard features:

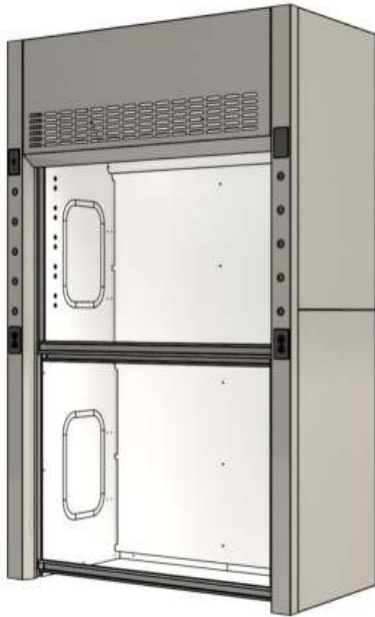

- Dual vertical rising sash.
- CSA Certified and UL Classified.
- A UL/CSA approved fluorescent light fixture complete with bulbs that provide a minimum work surface luminescence of 80 foot candles and a corner post mounted UL/CSA approved switch.
- Two UL/CSA approved duplex receptacles for 120 volt service - one receptacle on each corner post.
- Both corner posts pre-punched to accept a nominal of 5 plumbing fittings per post.
- Removable interior access panel in each side wall, two per side.
- Removable exterior side panels.
- Floor mounted fume hoods are designed to operate with only one sash open.
- Sash closes within 1" off the floor.

VERTICAL RAISING SASH (Cable sash system)					
Width	FRP	PVC	Epoxy	316 S/S Sq. Cor	316 S/S Rad. Cor
36"	7121001	7123001	7126001	7124001	7125001
48"	7221001	7223001	7226001	7224001	7225001
60"	7321001	7323001	7326001	7324001	7325001
72"	7421001	7423001	7426001	7424001	7425001
96"	7521001	7523001	7526001	7524001	7525001
1000mm	7B21001	7B23001	7B26001	7B24001	7B25001
1513mm	7C21001	7C23001	7C26001	7C24001	7C25001
2000mm	7D21001	7D23001	7D26001	7D24001	7D25001

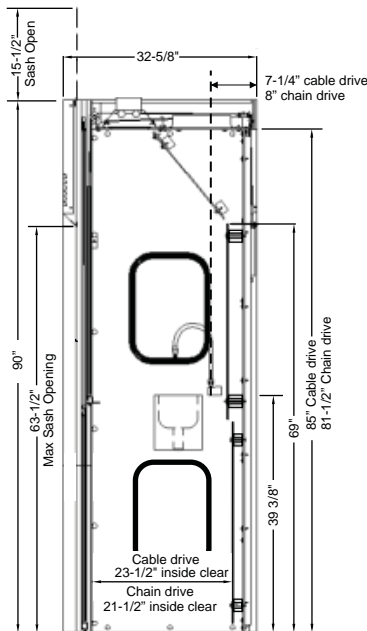

Cup sink location suits a gooseneck only.

VERTICAL RAISING SASH (Chain & Sprocket sash system)					
Width	FRP	PVC	Epoxy	316 S/S Sq. Cor	316 S/S Rad. Cor
36"	7121041	7123041	7126041	7124041	7125041
48"	7221041	7223041	7226041	7224041	7225041
60"	7321041	7323041	7326041	7324041	7325041
72"	7421041	7423041	7426041	7424041	7425041
96"	7521041	7523041	7526041	7524041	7525041
1000mm	7B21041	7B23041	7B26041	7B24041	7B25041
1513mm	7C21041	7C23041	7C26041	7C24041	7C25041
2000mm	7D21041	7D23041	7D26041	7D24041	7D25041

Exhaust Parameters		80 FPM		100 FPM	
		28-1/2 Max Sash Opening		28-1/2 Max Sash Opening	
Hood Size	Duct Dia.	CFM	SP	CFM	SP
36"	10"	434	0.05	543	0.10
48"	10"	630	0.15	789	0.20
60"	12"	830	0.15	1035	0.20
72"	12"	1025	0.20	1280	0.25
96"	2@10"	1418	0.20	1772	0.25
1000mm	10"	490	0.10	612	0.15
1513mm	12"	820	0.15	1025	0.20
2000mm	12"	1135	0.20	1419	0.30

*FUME HOODS  
PRO FLOOR MOUNTED - DUAL VERTICAL SASH WITH UPPER COMBINATION SASH*

**Features**

This all purpose fume hood is designed to meet most laboratory Constant Air Volume (CAV) or Variable Air Volume (VAV) requirements. Designed to sit directly on laboratory floor. The Pro fume hood is supplied with the following standard features:

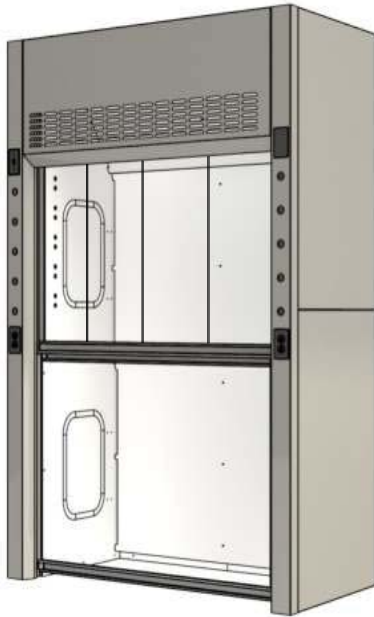

- Restricted upper by-pass is standard.
- Dual vertical rising sash with upper combination sash.
- CSA Certified and UL Classified.
- A UL/CSA approved fluorescent light fixture complete with bulbs that provide a minimum work surface luminescence of 80 foot candles and a corner post mounted UL/CSA approved switch.
- Two UL/CSA approved duplex receptacles for 120 volt service - one receptacle on each corner post.
- Both corner posts pre-punched to accept a nominal of 5 plumbing fittings per post.
- Removable interior access panel in each side wall, two per side.
- Removable exterior side panels.
- Floor mounted fume hoods are designed to operate with only one sash open.
- Sash closes within 1" off the floor.

Horizontal Panels On Combo Sash Hood		
Hood Width	Sash Width	# of Panels
48"	9-3/4"	4
60"	12-3/4"	4
72"	15-3/4"	4
96"	14-3/4"	6

VERTICAL RAISING SASH WITH UPPER COMBINATION SASH (Chain & Sprocket)					
Width	FRP	PVC	Epoxy	316 S/S Sq. Cor	316 S/S Rad. Cor
48"	7221051	7223051	7226051	7224051	7225051
60"	7321051	7323051	7326051	7324051	7325051
72"	7421051	7423051	7426051	7424051	7425051
96"	7521051	7523051	7526051	7524051	7525051
1513mm	7C21051	7C23051	7C26051	7C24051	7C25051
2000mm	7D21051	7D23051	7D26051	7D24051	7D25051

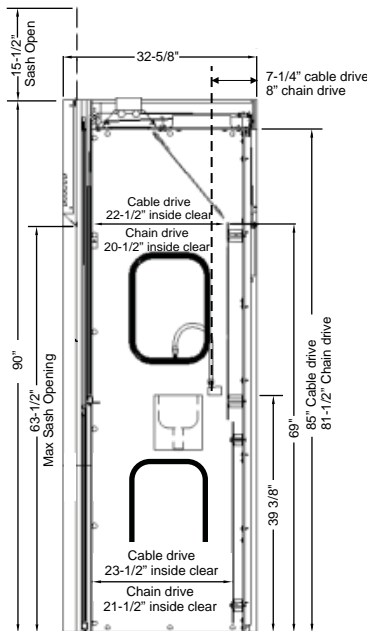

Cup sink location suits a gooseneck only.

Exhaust Parameters		80 FPM		100 FPM		80 FPM		100 FPM	
		Upper Door Only 1/2 Open		Upper Door Only 1/2 Open		18" Max Sash Opening		18" Max Sash Opening	
Hood Size	Duct Dia.	CFM	SP	CFM	SP	CFM	SP	CFM	SP
48"	10"	315	0.05	394	0.05	407	0.06	508	0.09
60"	12"	414	0.05	517	0.05	533	0.05	667	0.07
72"	12"	512	0.05	640	0.10	660	0.07	825	0.11
96"	2@10"	709	0.05	886	0.10	913	0.07	1142	0.11
1513mm	12"	410	0.05	513	0.10	528	0.05	660	0.07
2000mm	12"	567	0.05	709	0.10	731	0.09	914	0.14

**Note:** Exhaust parameters are based on lower sash door closed during active use.

*FUME HOODS  
PRO FLOOR MOUNTED - HORIZONTAL SLIDING SASH*

**Features**

This all purpose fume hood is designed to meet most laboratory Variable Air Volume (VAV) requirements. Designed to sit directly on laboratory floor.

The Pro fume hood is supplied with the following standard features:

- Restricted upper by-pass plate is standard.
- Horizontal sliding sash.
- CSA Certified and UL Classified.
- A UL/CSA approved fluorescent light fixture complete with bulbs that provide a minimum work surface luminescence of 80 foot candles and a corner post mounted UL/CSA approved switch.
- Two UL/CSA approved duplex receptacles for 120 volt service - one receptacle on each corner post.
- Both corner posts pre-punched to accept a nominal of 5 plumbing fittings per post.
- Removable interior access panel in each side wall, two per side.
- Removable exterior side panels.
- Floor mounted fume hoods are designed to operate with only one sash open.



HORIZONTAL PANELS ON SLIDING SASH		
Hood Width	Sash Width	# of Panels
48"	19-13/16"	2
60"	13-3/8"	4
72"	16-3/8"	4
96"	22-3/8"	4
120"	19-1/4"	6
144"	23-1/4"	6
1513mm	13-3/8"	4
2000mm	18-1/8"	4

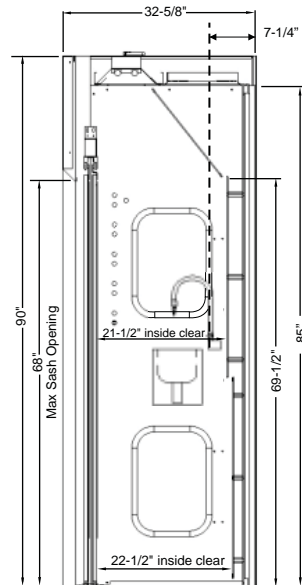

Cup sink location suits a gooseneck only.

Width	STAINLESS STEEL HORIZONTAL SLIDING SASH				
	FRP	PVC	Epoxy	316 S/S Sq. Cor	316 S/S Rad. Cor
48"	7221021	7223021	7226021	7224021	7225021
60"	7321021	7323021	7326021	7324021	7325021
72"	7421021	7423021	7426021	7424021	7425021
96"	7521021	7523021	7526021	7524021	7525021
120"	7621021	7623021	7626021	7624021	7625021
144"	7H21021	7H23021	7H26021	7H24021	7H25021
1513mm	7C21021	7C23021	7C26021	7C24021	7C25021
2000mm	7D21021	7D23021	7D26021	7D24021	7D25021

Exhaust Parameters		80 FPM		100 FPM	
		1/2 Sliding Doors Open		1/2 Sliding Doors Open	
Hood Size	Duct Dia.	CFM	SP	CFM	SP
48"	10"	680	0.20	849	0.25
60"	12"	890	0.15	1113	0.20
72"	12"	1102	0.20	1378	0.35
96"	2@10"	1525	0.20	1907	0.35
120"	2@12"	1950	0.15	2436	0.25
144"	2@12"	2373	0.25	2965	0.35
1513mm	12"	884	0.15	1104	0.20
2000mm	12"	1221	0.25	1527	0.40

*FUME HOODS*  
*OPTIMA™ FLOOR MOUNTED - VERTICAL SASH*

**Features**

Optima™ fume hoods have been specifically designed to meet the demanding safety, operational and ergonomic requirements of the modern laboratory. With its adjustable work surface and ADA features the Optima™ fume hood brings flexibility to the laboratory environment. This hood is designed to meet most laboratory constant air volume (CAV) and variable air volume (VAV) requirements.

The Optima™ fume hood is supplied with the following standard features:



- Optimized interior working area is achieved through sleek side posts and a minimized frame.
- Chain drive sash delivers the easiest and most reliable sash operation available with an exceptionally long life span.
- Restricted upper by-pass is standard.
- Vertical rising sash.
- Electro-hydraulic height adjustable work surface (work top included) with electric motor has the flexibility to be raised or lowered from 30" to 36" to accommodate the requirements for individual users, different procedures or equipment. Ideal for ADA applications.
- White dished epoxy work top is standard, black epoxy work top an available option.
- Low profile hinged airfoil is flush with work surface to provide easy access by keeping the work area open to accommodate equipment and procedures.
- Spill trough is designed to provide secondary containment in the event a spill.
- Self-Lowering Sash System automatically lowers the sash to the chosen working height. A latch shall be provided to hold the sash fully open for setup/teardown of experiments.
- Fixture holes are not pre-punched and punched only as ordered. For ADA applications a maximum of three fixtures per side only if the bottom fixture is for cold water. For standard applications corner posts can accept a maximum of five fixtures per side.
- Fixed baffle system that adjusts with the work surface for improved airflow through the fume hood.
- If cup sink is required, telescoping drain with a fixed drain cover is provided.
- Sash is made of 6mm laminated safety glass.
- Standard fiberglass reinforced polyester liner has excellent strength, chemical resistance, additional liner materials are also available.
- Gasketed access panels provide convenient access and prevent fume leakage outside the fume hood.
- The self-supporting structure allows for slide-in or mobile cabinets for easy relocation.
- Designed for 80-100 feet per minute face velocities.
- Meets all ASHRAE guidelines.
- CSA Certified.
- Two UL/CSA approved receptacles for 120 volt service - one receptacle on each end of the apron.
- A UL/CSA approved fluorescent light fixture complete with bulbs that provide a minimum work surface luminescence of 80 foot candles and an apron mounted UL/CSA approved switch.

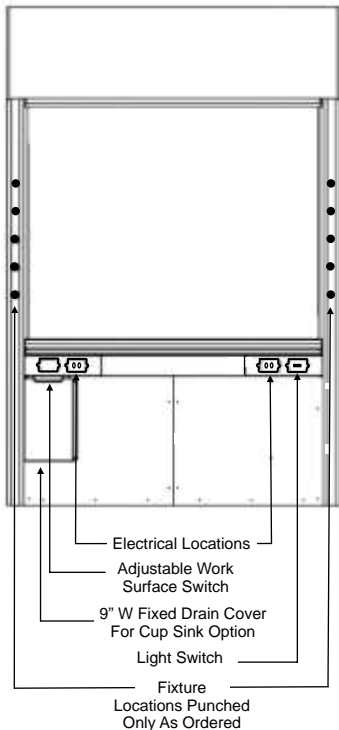

FRP LINER (Chain and Sprocket system)	
Width	Vertical Raising Sash
48"	72D1040
60"	73D1040
72"	74D1040

EXHAUST PARAMETERS		80 FPM		100 FPM	
		18" MAX SASH OPENING		18" MAX SASH OPENING	
Hood Width	Duct Dia.	CFM	SP	CFM	SP
48"	10"	465	0.07	581	0.11
60"	10"	591	0.11	739	0.18
72"	12"	718	0.18	897	0.27

**NOTE:** Fully open sash is for set-up and teardown of experiments only. Work should not be performed in the set-up position.



*FUME HOODS*  
*OPTIMA™ FLOOR MOUNTED - COMBINATION SASH*

**Features**

Optima™ fume hoods have been specifically designed to meet the demanding safety, operational and ergonomic requirements of the modern laboratory. With its adjustable work surface and ADA features the Optima™ fume hood brings flexibility to the laboratory environment. This hood is designed to meet most laboratory constant air volume (CAV) and variable air volume (VAV) requirements.

The Optima™ fume hood is supplied with the following standard features:



- Optimized interior working area is achieved through sleek side posts and a minimized frame.
- Chain drive sash delivers the easiest and most reliable sash operation available with an exceptionally long life span.
- Restricted upper by-pass is standard.
- Top hung frameless combination vertical rising sash and horizontal sliding sash.
- Electro-hydraulic height adjustable work surface (work top included) with electric motor has the flexibility to be raised or lowered from 30" to 36" to accommodate the requirements for individual users, different procedures or equipment. Ideal for ADA applications.
- White dished epoxy work top is standard, black epoxy work top an available option.
- Low profile hinged airfoil is flush with work surface to provide easy access by keeping the work area open to accommodate equipment and procedures.
- Spill trough is designed to provide secondary containment in the event a spill.
- Self-Lowering Sash System automatically lowers the sash to the chosen working height. A latch shall be provided to hold the sash fully open for setup/teardown of experiments.
- Fixture holes are not pre-punched and punched only as ordered. For ADA applications a maximum of three fixtures per side only if the bottom fixture is for cold water. For standard applications corner posts can accept a maximum of five fixtures per side.
- Fixed baffle system that adjusts with the work surface for improved airflow through the fume hood.
- If cup sink is required, telescoping drain with a fixed drain cover is provided.
- Sash is made of 6mm laminated safety glass.
- Standard fiberglass reinforced polyester liner has excellent strength, chemical resistance, additional liner materials are also available.
- Upper gasketed access panels provide convenient access and prevent fume leakage outside the fume hood.
- The self-supporting structure allows for slide-in or mobile cabinets for easy relocation.
- Designed for 80-100 feet per minute face velocities.
- Meets all ASHRAE guidelines.
- CSA Certified.
- Two UL/CSA approved receptacles for 120 volt service - one receptacle on each end of the apron.
- A UL/CSA approved fluorescent light fixture complete with bulbs that provide a minimum work surface luminescence of 80 foot candles and an apron mounted UL/CSA approved switch.

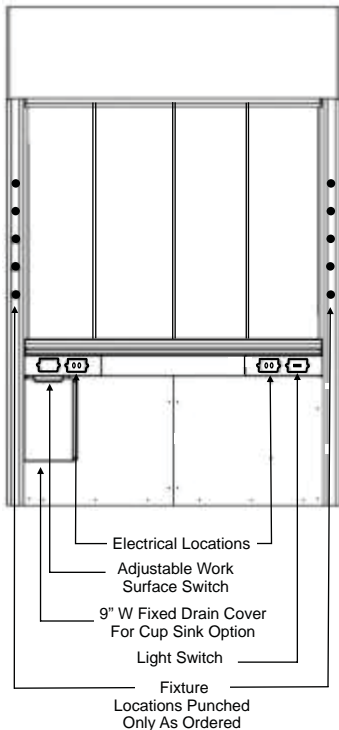

FRP LINER (Chain and Sprocket system)	
Width	Combination Sash
48"	72D1050
60"	73D1050
72"	74D1050

HORIZONTAL PANELS ON COMBINATION SASH		
Hood Width	Sash Width	# of Panels
48"	10-5/8"	4
60"	13-5/8"	4
72"	16-5/8"	4

EXHAUST PARAMETERS		100 FPM		100 FPM	
		SASH OPEN HORIZONTALLY ONLY		18" MAX SASH OPENING	
Hood Width	Duct Dia.	CFM	SP	CFM	SP
48"	10"	585	0.12	525	0.1
60"	10"	750	0.19	675	0.16
72"	12"	917	0.14	825	0.11

**NOTE:** Fully open sash is for set-up and teardown of experiments only. Work should not be performed in the set-up position.

**FUME HOODS**
**39-1/4" DEEP HOPEC IV FULLY ACCESSIBLE COMBINATION SASH**
**Features**

This fume hood is designed to be accessed from standing and sitting positions. Suitable for Constant Air Volume (CAV) and Variable Air Volume (VAV) requirements. Designed to mount on a 30" deep counter top. The Pro bench mounted fume hood is supplied with the following standard features:

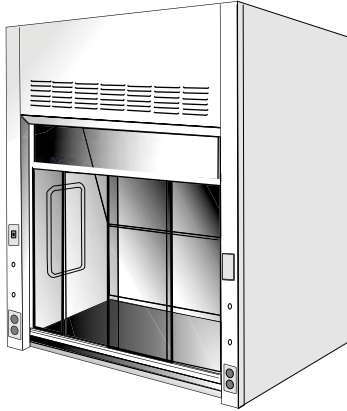

- Restricted upper by-pass is standard.
- Combination vertical rising and horizontal sliding sash.
- Spring loaded stainless steel sash stop at 18" and 0".
- An automatic compensating restricted upper by-pass.
- A lower airfoil by-pass with stainless steel spill trough.
- CSA Certified and UL Classified.
- A UL/CSA approved fluorescent light fixture complete with bulbs that provide a minimum work surface luminescence of 80 foot candles and a corner post mounted UL/CSA approved switch.
- Two UL/CSA approved duplex receptacles for 120 volt service - one receptacle on each corner post.
- Both corner posts pre-punched to accept a maximum of 2 plumbing fittings per post.
- Removable interior access panel in each side wall.
- Removable exterior side panels.
- Fume hoods with type 316 stainless steel radiused corner interiors are manufactured with an integral stainless steel wood core top.
- Front mounted safety glass shield.

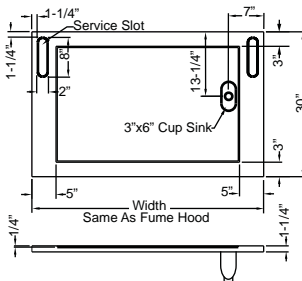
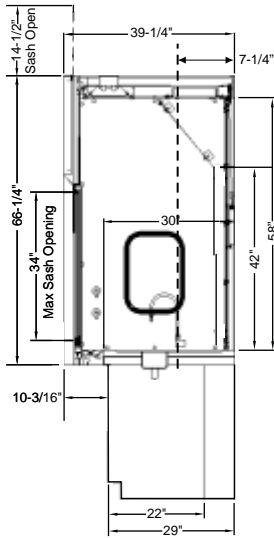

Cup sink location suits a rear mounted gooseneck only.

HORIZONTAL PANELS ON COMBINATION SASH		
Hood Width	Sash Width	# of Panels
48"	9-3/4"	4
60"	12-3/4"	4
72"	15-3/4"	4
96"	14-13/16"	6

VERTICAL RAISING SASH (Cable sash system)					
Width	FRP	PVC	Epoxy	316 S/S Sq. Cor	316 S/S Rad. Cor
48"	7291010	7293010	7296010	7294010	7295010
60"	7391010	7393010	7396010	7394010	7395010
72"	7491010	7493010	7496010	7494010	7495010
96"	7591010	7593010	7596010	7594010	7595010
1513mm	7C91010	7C93010	7C96010	7C94010	7C95010
2000mm	7D91010	7D93010	7D96010	7D94010	7D95010

VERTICAL RAISING SASH (Chain & Sprocket sash system)					
Width	FRP	PVC	Epoxy	316 S/S Sq. Cor	316 S/S Rad. Cor
48"	7291050	7293050	7296050	7294050	7295050
60"	7391050	7393050	7396050	7394050	7395050
72"	7491050	7493050	7496050	7494050	7495050
96"	7591050	7593050	7596050	7594050	7595050
1513mm	7C91050	7C93050	7C96050	7C94050	7C95050
2000mm	7D91050	7D93050	7D96050	7D94050	7D95050

Exhaust Parameters		80 FPM		100 FPM		80 FPM		100 FPM	
		28-1/2 Max Sash Opening		28-1/2 Max Sash Opening		18 Max Sash Opening		18 Max Sash Opening	
Hood Size	Duct Dia.	CFM	SP	CFM	SP	CFM	SP	CFM	SP
48"	10"	630	0.15	789	0.20	407	0.06	508	0.09
60"	12"	830	0.15	1035	0.20	533	0.05	667	0.07
72"	12"	1025	0.20	1280	0.25	660	0.07	825	0.11
96"	2@10"	1418	0.20	1772	0.25	913	0.07	1142	0.11
1513mm	12"	820	0.15	1025	0.20	528	0.05	660	0.07
2000mm	12"	1135	0.20	1419	0.30	731	0.09	914	0.14



**FUME HOODS**  
**32-5/8" DEEP FULLY ACCESSIBLE COMBINATION SASH**

**Features**

This fume hood is designed to be accessed from standing and sitting positions. Suitable for Constant Air Volume (CAV) and Variable Air Volume (VAV) applications. Designed to mount on a 23-3/8" deep counter top. The Pro bench mounted fume hood is supplied with the following standard features:



- Restricted upper by-pass is standard.
- Combination vertical rising and horizontal sliding sash.
- Spring loaded stainless steel sash stop at 18" and 0".
- An automatic compensating restricted upper by-pass.
- A lower airfoil by-pass with stainless steel spill trough.
- CSA Certified and UL Classified.
- A UL/CSA approved fluorescent light fixture complete with bulbs that provide a minimum work surface luminescence of 80 foot candles and a corner post mounted UL/CSA approved switch.
- Two UL/CSA approved duplex receptacles for 120 volt service - one receptacle on each corner post.
- Both corner posts pre-punched to accept a maximum of 2 plumbing fittings per post.
- Removable interior access panel in each side wall.
- Removable exterior side panels.
- Fume hoods with type 316 stainless steel radiused corner interiors are manufactured with an integral stainless steel wood core top.
- Front mounted safety glass shield.

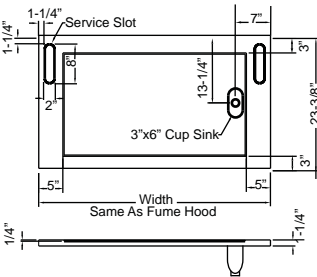
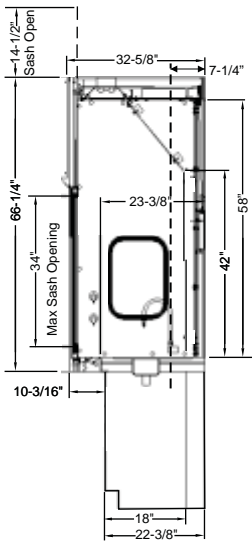

Cup sink location suits a rear mounted gooseneck only.

HORIZONTAL PANELS ON COMBINATION SASH		
Hood Width	Sash Width	# of Panels
48"	9-3/4"	4
60"	12-3/4"	4
72"	15-3/4"	4
96"	14-13/16"	6

COMBINATION SASH (Cable sash system)					
Width	FRP	PVC	Epoxy	316 S/S Sq. Cor	316 S/S Rad. Cor
48"	7241010	7243010	7246010	7244010	7245010
60"	7341010	7343010	7346010	7344010	7345010
72"	7441010	7443010	7446010	7444010	7445010
96"	7541010	7543010	7546010	7544010	7545010
1513mm	7C41010	7C43010	7C46010	7C44010	7C45010
2000mm	7D41010	7D43010	7D46010	7D44010	7D45010

COMBINATION SASH (Chain & sprocket sash system)					
Width	FRP	PVC	Epoxy	316 S/S Sq. Cor	316 S/S Rad. Cor
48"	7241050	7243050	7246050	7244050	7245050
60"	7341050	7343050	7346050	7344050	7345050
72"	7441050	7443050	7446050	7444050	7445050
96"	7541050	7543050	7546050	7544050	7545050
1513mm	7C41050	7C43050	7C46050	7C44050	7C45050
2000mm	7D41050	7D43050	7D46050	7D44050	7D45050

Exhaust Parameters		80 FPM		100 FPM		80 FPM		100 FPM	
		28-1/2 Max Sash Opening		28-1/2 Max Sash Opening		18 Max Sash Opening		18 Max Sash Opening	
Hood Size	Duct Dia.	CFM	SP	CFM	SP	CFM	SP	CFM	SP
48"	10"	630	0.15	789	0.20	407	0.06	508	0.09
60"	12"	830	0.15	1035	0.20	533	0.05	667	0.07
72"	12"	1025	0.20	1280	0.25	660	0.07	825	0.11
96"	2@10"	1418	0.20	1772	0.25	913	0.07	1142	0.11
1513mm	12"	820	0.15	1025	0.20	528	0.05	660	0.07
2000mm	12"	1135	0.20	1419	0.30	731	0.09	914	0.14

*FUME HOODS  
PRO PERCHLORIC ACID BENCH - VERTICAL SASH*

**Features**

Designed to meet the stringent requirements of perchloric acid applications and suitable for Constant Air Volume (CAV) requirements only. Complete with 30" deep seamlessly welded counter top of the same material as liner. The Pro bench mounted fume hood is supplied with the following standard features:



- Vertical rising sash.
- An automatic compensating upper by-pass .
- A lower airfoil by-pass with electrical cord notches.
- Removable baffle.
- CSA Certified and UL Classified.
- A UL/CSA approved fluorescent light fixture complete with bulbs that provide a minimum work surface luminescence of 80 foot candles and a corner post mounted UL/CSA approved switch.
- Two UL/CSA approved duplex receptacles for 120 volt service - one receptacle on each corner post.
- Both corner posts pre-punched to accept a maximum of 5 plumbing fittings per post.
- Removable exterior side panels.
- Two liner materials are available.
- Pre plumbed internal wash down system with rear spray bar, control valve to match plumbing, trough and drain.
- All type 316 stainless steel hoods with radiused corners are manufactured with hat channel top construction.
- Perchloric acid hood must be connected to a dedicated exhaust system designed specifically for perchloric acid use.
- Stainless steel liner suitable for straight perchloric acid only. For other acids, please contact Mott Manufacturing for details.

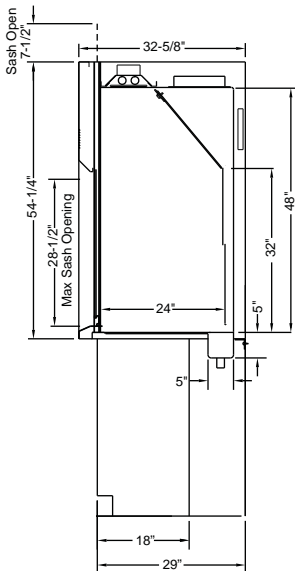

VERTICAL RAISING SASH (Cable sash system)		
Width	316 S/S Rad. Cor	PVC Rad. Cor
36"	7127000	7129000
48"	7227000	7229000
60"	7327000	7329000
72"	7427000	7429000
96"	7527000	7529000
1000mm	7B27000	7B29000
1513mm	7C27000	7C29000
2000mm	7D27000	7D29000

Exhaust Parameters		80 FPM		100 FPM		80 FPM		100 FPM	
		28-1/2 Max Sash Opening		28-1/2 Max Sash Opening		18 Max Sash Opening		18 Max Sash Opening	
Hood Size	Duct Dia.	CFM	SP	CFM	SP	CFM	SP	CFM	SP
36"	10"	434	0.05	543	0.10	280	0.03	350	0.04
48"	10"	630	0.15	789	0.20	407	0.06	508	0.09
60"	12"	830	0.15	1035	0.20	533	0.05	667	0.07
72"	12"	1025	0.20	1280	0.25	660	0.07	825	0.11
96"	2@10"	1418	0.20	1772	0.25	913	0.07	1142	0.11
1000mm	10"	490	0.10	612	0.15	316	0.04	395	0.05
1513mm	12"	820	0.15	1025	0.20	528	0.05	660	0.07
2000mm	12"	1135	0.20	1419	0.30	731	0.09	914	0.14

*FUME HOODS  
PRO RADIOISOTOPE BENCH - VERTICAL SASH*

**Features**

Designed to meet the stringent requirements of radioisotope applications and meet most laboratory Constant Air Volume (CAV) or Variable Air Volume (VAV) requirements. For VAV use add option S2. Complete with 30" deep seamlessly welded stainless steel counter top. The Pro bench mounted fume hood is supplied with the following standard features:



- Vertical rising sash .
- An automatic compensating upper by-pass .
- Add option code S2 for a restricted damper by-pass.
- A lower airfoil by-pass with electrical cord notches.
- CSA Certified UL Classified.
- A UL/CSA approved fluorescent light fixture complete with bulbs that provide a minimum work surface luminescence of 80 foot candles and a corner post mounted UL/CSA approved switch.
- Two UL/CSA approved duplex receptacles for 120 volt service - one receptacle on each corner post.
- Both corner posts pre-punched to accept a maximum of 5 plumbing fittings per post.
- All weld joints are ground smooth and polished.
- Integral work surface reinforced with galvanized steel hat channels.
- All type 316 stainless steel hoods with radiused corners are manufactured with hat channel top construction.

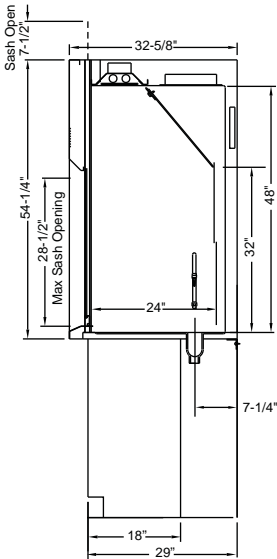

VERTICAL RAISING SASH (Cable sash system)		VERTICAL RAISING SASH (Chain sash system)	
Width	316 S/S RAD. COR	Width	316 S/S RAD. COR
36"	7128000	36"	7128040
48"	7228000	48"	7228040
60"	7328000	60"	7328040
72"	7428000	72"	7428040
96"	7528000	96"	7528040
1000mm	7B28000	1000mm	7B28040
1513mm	7C28000	1513mm	7C28040
2000mm	7D28000	2000mm	7D28040

Exhaust Parameters		80 FPM		100 FPM		80 FPM		100 FPM	
		28-1/2 Max Sash Opening		28-1/2 Max Sash Opening		18 Max Sash Opening		18 Max Sash Opening	
Hood Size	Duct Dia.	CFM	SP	CFM	SP	CFM	SP	CFM	SP
36"	10"	434	0.05	543	0.10	280	0.03	350	0.04
48"	10"	630	0.15	789	0.20	407	0.06	508	0.09
60"	12"	830	0.15	1035	0.20	533	0.05	667	0.07
72"	12"	1025	0.20	1280	0.25	660	0.07	825	0.11
96"	2@10"	1418	0.20	1772	0.25	913	0.07	1142	0.11
1000mm	10"	490	0.10	612	0.15	316	0.04	395	0.05
1513mm	12"	820	0.15	1025	0.20	528	0.05	660	0.07
2000mm	12"	1135	0.20	1419	0.30	731	0.09	914	0.14

*FUME HOODS*  
*PRO DEMONSTRATION BENCH - VERTICAL SASH*

**Features**

Designed to permit demonstration and observation from both sides and meets most laboratory Variable Air Volume (VAV) requirements. Can be used either free standing or positioned within a wall between a classroom and a prep room. Mounts on a 30" deep counter top. The Pro bench mounted fume hood is supplied with the following standard features:

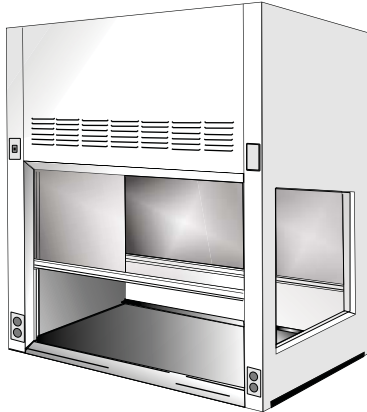

Fume hood shown with option W1

- Two separate vertical rising sashes.
- Restricted upper by-pass is standard.
- A lower airfoil by-pass with electrical cord notches.
- Optional upper baffle configuration.
- CSA Certified and UL Classified.
- A UL/CSA approved fluorescent light fixture complete with bulbs that provide a minimum work surface luminescence of 80 foot candles and a corner post mounted UL/CSA approved switch.
- Four UL/CSA approved duplex receptacles for 120 volt service - one receptacle on each corner post.
- Two corner posts pre-punched to accept a maximum of 5 plumbing fittings per post, at one end, opposite end reserved for counter weights.
- Removable interior access panel on same side wall as plumbing.
- Removable exterior side panels.
- Corner post mounted UL/CSA approved three-way light switch on both sides of hood.
- Alarm mounting recommended on end with plumbing.
- Special airflow consideration required when installing between two rooms - Please contact Mott Manufacturing for more information.

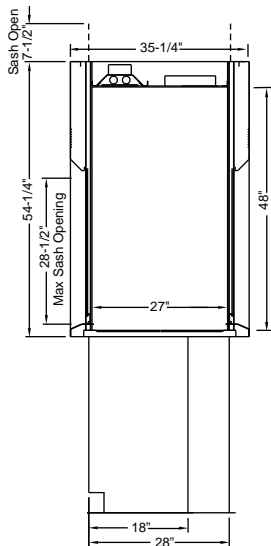

VERTICAL RAISING SASH (Cable sash system)	
Width	FRP
36"	7121002
48"	7221002
60"	7321002
72"	7421002
96"	7521002
1000mm	7B21002
1513mm	7C21002
2000mm	7D21002

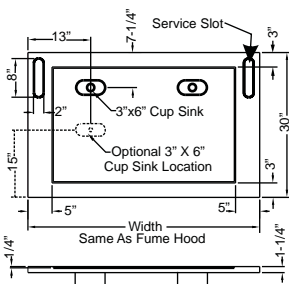

Typical fume hood work top showing optional cup sinks located for 18" deep cabinets.

Optional cup sink location if sink cabinet is located below fume hood.

Cup sink location suits a gooseneck only.

Exhaust Parameters		80 FPM		100 FPM		80 FPM		100 FPM	
		28-1/2 Max Sash Opening		28-1/2 Max Sash Opening		18 Max Sash Opening		18 Max Sash Opening	
Hood Size	Duct Dia.	CFM	SP	CFM	SP	CFM	SP	CFM	SP
36"	10"	434	0.05	543	0.10	280	0.03	350	0.04
48"	10"	630	0.15	789	0.20	407	0.06	508	0.09
60"	12"	830	0.15	1035	0.20	533	0.05	667	0.07
72"	12"	1025	0.20	1280	0.25	660	0.07	825	0.11
96"	2@10"	1418	0.20	1772	0.25	913	0.07	1142	0.11
1000mm	10"	490	0.10	612	0.15	316	0.04	395	0.05
1513mm	12"	820	0.15	1025	0.20	528	0.05	660	0.07
2000mm	12"	1135	0.20	1419	0.30	731	0.09	914	0.14

**Note :** Only one sash is open in CFM calculations.

**Note :** Special airflow consideration required when installing between two rooms. Please contact Mott Manufacturing for more information.

**OPTIONS**

- S8** Sash Interlock (Allows only one sash to be opened at a time)
- S9** Sash Key Lock on both doors (Sash stop with key to lock sash in place)
- W1** End window (One end only. Note services must be work surface mounted)

**FUME HOODS**  
**RFV2™ BENCH - VERTICAL SASH**

**Features**

Designed to deliver competitive containment performance and energy efficiency. The RFV2™ operates with exhaust volumes significantly lower than conventional fume hoods. Providing the fume hood operator with a secure and reliable operation environment while providing considerable capital and operating cost savings. Suitable for Constant Air Volume (CAV) and Variable Air Volume (VAV) requirements. The RFV2™ bench mounted fume hood is supplied with the following standard features:

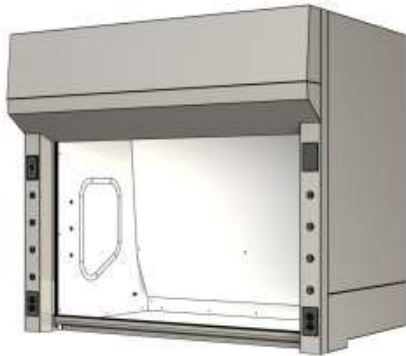

- Excellent containment performance at low face velocities. The RFV2™ fume hood has been tested to both standard and modified ASHRAE procedures at face velocities as low as 50 fpm.
- Vertical rising sash.
- Chain and sprocket sash counterbalance system.
- Downflow rear baffle is biased to the bottom, drawing fumes downward away from the user and counteracts the normal upward flow of vapors.
- Downwardly vectored upper by-pass prevents contaminated air build up behind the open sash.
- Supplementary mechanical fans, baffle actuators and controls not required.
- Full viewing sash provides a clear and unobstructed side to side view of fume hood interior, with a 34" high viewing area.
- Auto sash leveler automatically closes to the 18" height which decreases exhaust air and offers extra protection to the operator.
- Self-lowering sash system provides a sash latch to temporarily secure the sash in the full open position for set-up and tear down operations. When the lock is freed, the sash automatically returns to the operational position.
- Hinged powder coated, type 316 stainless steel airfoil is flush with work surface for easy cleaning.
- CSA certified.
- A UL/CSA approved fluorescent light fixture complete with bulbs that provide a minimum work surface luminescence of 80 foot candles and a corner post mounted UL/CSA approved switch.
- Two UL/CSA approved duplex receptacles for 120 volt service - one receptacle on each corner post.
- Two corner posts pre-punched to accept a maximum of 4 plumbing fittings per post.
- Removable interior and exterior access panels.
- Rectangular exhaust collar.

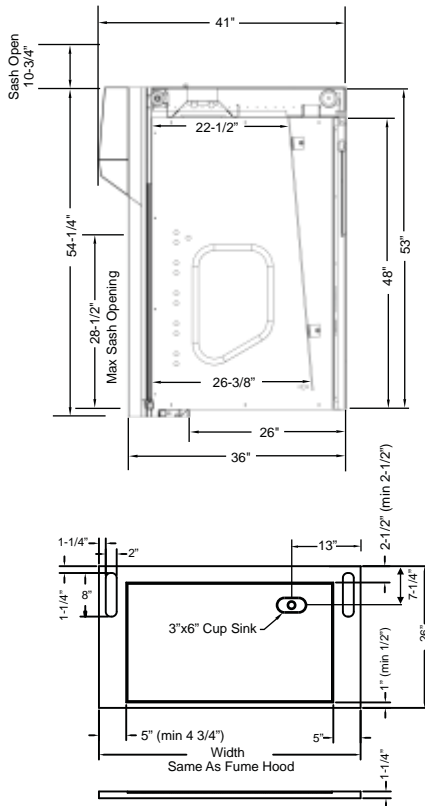

VERTICAL RAISING SASH (Chain sash system)					
Width	FRP	PVC	Epoxy	316 S/S Sq. Cor	316 S/S Rad. Cor
48"	72F1040	72F3040	72F6040	72F4040	72F5040
60"	73F1040	73F3040	73F6040	73F4040	73F5040
72"	74F1040	74F3040	74F6040	74F4040	74F5040
96"	75F1040	75F3040	75F6040	75F4040	75F5040

Exhaust Parameters		60 FPM		95 FPM		60 FPM	
		28-1/2 Max Sash Opening		18 Max Sash Opening		18 Max Sash Opening	
Hood Size	Duct Size	CFM	SP*	CFM	SP*	CFM	SP*
48"	3" x 36"	457	0.05	457	0.05	289	0.02
60"	3" x 36"	600	0.07	600	0.07	379	0.03
72"	3" x 36"	742	0.1	742	0.1	469	0.04
96"	3" x 36"	1027	0.2	1027	0.2	649	0.08

Note: \* Does not include transition

EXHAUST TRANSITION		
Hood Width	Item Number	Duct Size
48", 60", 72"	EXT0036	10"
96"	EXT2336	12"

- ∞ Fits over vent collar on RFV2™ fume hoods.
- ∞ Exhaust transitions (rectangular duct to round duct) are available in 20 gauge, Type 316 stainless steel or powder coated galvanized steel and fits over vent collar.
- ∞ Base Size 3" x 36".

**FUME HOODS**  
**RFV2™ BENCH - COMBINATION SASH**

**Features**

Designed to deliver competitive containment performance and energy efficiency. The RFV2™ operates with exhaust volumes significantly lower than conventional fume hoods. Providing the fume hood operator with a secure and reliable operation environment while providing considerable capital and operating cost savings. Suitable for Constant Air Volume (CAV) and Variable Air Volume (VAV) requirements. The RFV2™ bench mounted fume hood is supplied with the following standard features:

- Excellent containment performance at low face velocities. The RFV2™ fume hood has been tested to both standard and modified ASHRAE procedures at face velocities as low as 50 fpm.
- Combination vertical rising and horizontal sliding sash.
- Chain and sprocket sash counterbalance system.
- Downflow rear baffle is biased to the bottom, drawing fumes downward away from the user and counteracts the normal upward flow of vapors.
- Downwardly vectored upper by-pass prevents contaminated air build up behind the open sash.
- Supplementary mechanical fans, baffle actuators and controls not required.
- Full viewing sash provides a clear and unobstructed side to side view of fume hood interior, with a 34" high viewing area.
- Auto sash leveler automatically closes to the 18" height which decreases exhaust air and offers extra protection to the operator.
- Self-lowering sash system provides a sash latch to temporarily secure the sash in the full open position for set-up and tear down operations. When the lock is freed, the sash automatically returns to the operational position.
- Hinged powder coated, type 316 stainless steel airfoil is flush with work surface for easy cleaning.
- UL1805 classified and CSA certified.
- A UL/CSA approved fluorescent light fixture complete with bulbs that provide a minimum work surface luminescence of 80 foot candles and a corner post mounted UL/CSA approved switch.
- Two UL/CSA approved duplex receptacles for 120 volt service - one receptacle on each corner post.
- Two corner posts pre-punched to accept a maximum of 4 plumbing fittings per post.
- Removable interior and exterior access panels.
- Rectangular exhaust collar.

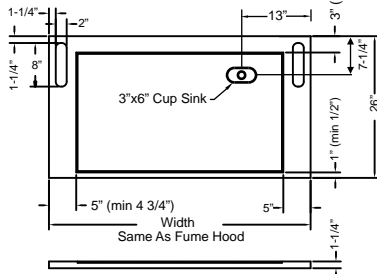
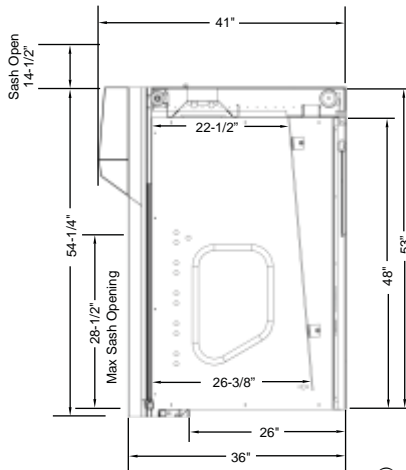
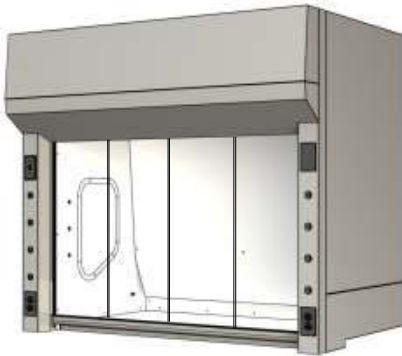

Note: Cup sink location suits a gooseneck only.

COMBINATION SASH (Chain sash system)					
Width	FRP	PVC	Epoxy	316 S/S Sq. Cor	316 S/S Rad. Cor
48"	72F1050	72F3050	72F6050	72F4050	72F5050
60"	73F1050	73F3050	73F6050	73F4050	73F5050
72"	74F1050	74F3050	74F6050	74F4050	74F5050
96"	75F1050	75F3050	75F6050	75F4050	75F5050

Exhaust Parameters		60 FPM		100 FPM	
		28-1/2" Max Sash Opening		Sash Open Horizontally Only	
Hood Size	Duct Size	CFM	SP*	CFM	SP*
48"	3" x 36"	457	0.05	457	0.05
60"	3" x 36"	600	0.07	600	0.07
72"	3" x 36"	742	0.1	742	0.1
96"	3" x 36"	1027	0.2	1027	0.2

Note: \* Does not include transition

EXHAUST TRANSITION		
Hood Width	Item Number	Duct Size
48", 60", 72"	EXT0036	10"
96"	EXT2336	12"

HORIZONTAL PANELS ON COMBINATION SASH		
Hood Width	Sash Width	# of Panels
48"	9-3/4"	4
60"	12-3/4"	4
72"	15-3/4"	4
96"	14-13/16"	6

- ∞ Fits over vent collar on RFV2™ fume hoods.
- ∞ Exhaust transitions (rectangular duct to round duct) are available in 20 gauge, Type 316 stainless steel or powder coated galvanized steel and fits over vent collar.
- ∞ Base Size 3" x 36".



*FUME HOODS*  
*SAFEGUARD™ BENCH - VERTICAL SASH*

**Features**

The SafeGuard™ fume hood represents a balance of key safety elements and new design. The SafeGuard™ Constant Air Volume (CAV) or Variable Air Volume (VAV) fume hood has been developed to meet the challenging safety, energy conservation, and operational requirements of today's laboratory. The new contemporary design creates a stylish image for today's modern lab environment. For VAV use add option S2. The SafeGuard™ bench mounted fume hood is supplied with the following standard features:

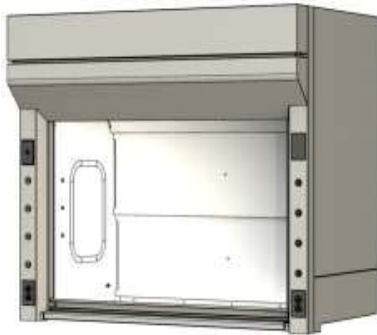

- Vertical rising sash.
- Chain and sprocket sash counterbalance system.
- For variable air volume (VAV) requirements, use optional Restricted By-Pass Plate (option code S2).
- Low profile powder coated, type 316 stainless steel hinged airfoil is flush with work surface to provide easy access by keeping the work surface open to accommodate equipment and procedures and for easy cleaning.
- The airfoil allows for the safe introduction of electrical wiring into the fume hood in a manner that still allows the full closure of the sash.
- 34" high sash glass allows for superior visibility of the fume hood interior.
- Air flows through the downward directed bypass.
- UL/CSA approved fluorescent light fixture complete with bulbs that provide a minimum work surface luminescence of 80 foot candles and a corner post mounted UL/CSA approved switch.
- Two UL/CSA approved duplex receptacles for 120 volt service - one receptacle on each corner post.
- Two corner posts pre-punched to accept a maximum of 4 plumbing fittings per post.
- Removable interior access panels.
- Removable exterior side panels.
- Auto sash leveler automatically closes to the 18" height which decreases exhaust air and offers extra protection to the operator.
- Plastic latch is available to temporarily secure the sash in the full open position for setup and teardown operations. When the lock is freed, the sash automatically returns to the operational position.
- Designed for 60-100 feet per minute face velocities.
- Meets all ASHRAE 110-95 Standards.
- UL 1805 Classified.
- Round exhaust collar.

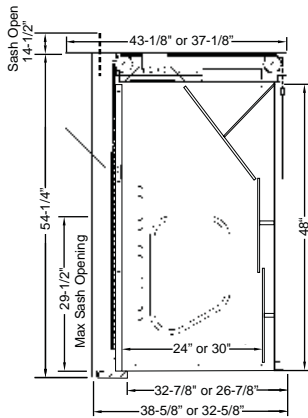

32-5/8" DEEP VERTICAL RAISING SASH (Chain sash system)					
Width	FRP	PVC	Epoxy	316 S/S Sq. Cor	316 S/S Rad. Cor
48"	7271040	7273040	7276040	7274040	7275040
60"	7371040	7373040	7376040	7374040	7375040
72"	7471040	7473040	7476040	7474040	7475040
96"	7571040	7573040	7576040	7574040	7575040

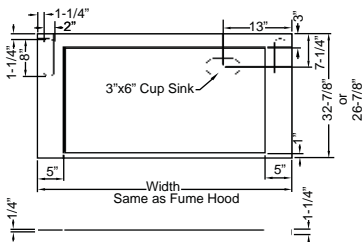

38-5/8" DEEP VERTICAL RAISING SASH (Chain sash system)					
Width	FRP	PVC	Epoxy	316 S/S Sq. Cor	316 S/S Rad. Cor
48"	7271040-ED	7273040-ED	7276040-ED	7274040-ED	7275040-ED
60"	7371040-ED	7373040-ED	7376040-ED	7374040-ED	7375040-ED
72"	7471040-ED	7473040-ED	7476040-ED	7474040-ED	7475040-ED
96"	7571040-ED	7573040-ED	7576040-ED	7574040-ED	7575040-ED

Typical fume hood work top showing optional cup sinks located for 18" deep cabinets.

Cup sink location suits a gooseneck only.

Exhaust Parameters		60 FPM		80 FPM		100 FPM	
		29-1/2" Max Sash Opening		18" Max Sash Opening		18" Max Sash Opening	
Hood Size	Duct Dia.	CFM	SP	CFM	SP	CFM	SP
48"	10"	481	0.08	385	0.05	481	0.08
60"	12"	631	0.07	505	0.04	631	0.07
72"	12"	781	0.1	625	0.06	781	0.1
96"	2@10"	1082	0.1	865	0.06	1082	0.1



## FUME HOODS SAFEGUARD™ BENCH - COMBINATION SASH

### Features

The SafeGuard™ fume hood represents a balance of key safety elements and new design. The SafeGuard™ is designed to meet most laboratory Constant Air Volume (CAV) and Variable Air Volume (VAV) requirements. Developed to meet the challenging safety, energy conservation, and operational requirements of today's laboratory, the new contemporary design creates a stylish image for today's modern lab environment. The SafeGuard™ bench mounted fume hood is supplied with the following standard features:

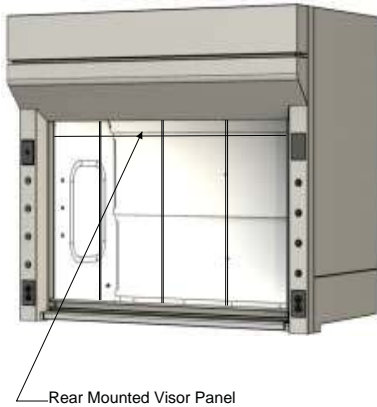

- Combination vertical rising and horizontal sliding sash.
- Chain and sprocket sash counterbalance system.
- Restricted upper by-pass is standard.
- Low profile powder coated, type 316 stainless steel hinged airfoil is flush with work surface to provide easy access by keeping the work surface open to accommodate equipment and procedures and for easy cleaning.
- The airfoil allows for the safe introduction of electrical wiring into the fume hood in a manner that still allows the full closure of the sash.
- 34" high sash glass allows for superior visibility of the fume hood interior.
- Air flows through the downward directed bypass.
- UL/CSA approved fluorescent light fixture complete with bulbs that provide a minimum work surface luminescence of 80 foot candles and a corner post mounted UL/CSA approved switch.
- Two UL/CSA approved duplex receptacles for 120 volt service - one receptacle on each corner post.
- Two corner posts pre-punched to accept a maximum of 4 plumbing fittings per post.
- Removable interior access panels.
- Removable exterior side panels.
- Auto sash leveler automatically closes to the 18" height which decreases exhaust air and offers extra protection to the operator.
- Plastic latch is available to temporarily secure the sash in the full open position for setup and teardown operations. When the lock is freed, the sash automatically returns to the operational position.
- Designed for 60-100 feet per minute face velocities.
- Meets all ASHRAE 110-95 Standards.
- UL 1805 Classified.
- Round exhaust collar.

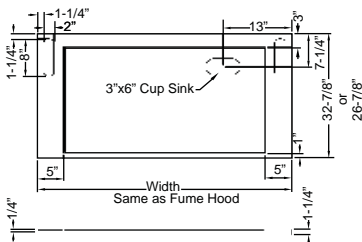
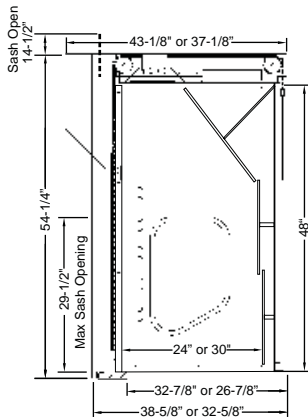

Typical fume hood work top showing optional cup sinks located for 18" deep cabinets.

Cup sink location suits a gooseneck only.

32-5/8" DEEP COMBINATION SASH (Chain sash system)					
Width	FRP	PVC	Epoxy	316 S/S Sq. Cor	316 S/S Rad. Cor
48"	7271050	7273050	7276050	7274050	7275050
60"	7371050	7373050	7376050	7374050	7375050
72"	7471050	7473050	7476050	7474050	7475050
96"	7571050	7573050	7576050	7574050	7575050

38-5/8" DEEP COMBINATION SASH (Chain sash system)					
Width	FRP	PVC	Epoxy	316 S/S Sq. Cor	316 S/S Rad. Cor
48"	7271050-ED	7273050-ED	7276050-ED	7274050-ED	7275050-ED
60"	7371050-ED	7373050-ED	7376050-ED	7374050-ED	7375050-ED
72"	7471050-ED	7473050-ED	7476050-ED	7474050-ED	7475050-ED
96"	7571050-ED	7573050-ED	7576050-ED	7574050-ED	7575050-ED

Exhaust Parameters		100 FPM		100 FPM		80 FPM		80 FPM	
		Combo Sash Open Horizontally		18" Max Sash Opening		Combo Sash Open Horizontally		18" Max Sash Opening	
Hood Size	Duct Dia.	CFM	SP	CFM	SP	CFM	SP	CFM	SP
48"	10"	376	0.05	481	0.08	305	0.03	385	0.05
60"	12"	495	0.04	631	0.07	400	0.03	505	0.04
72"	12"	613	0.06	781	0.1	495	0.04	625	0.06
96"	2@10"	856	0.06	1082	0.1	685	0.04	865	0.06

Exhaust Parameters		60 FPM	
		29-1/2" Max Sash Opening	
Hood Size	Duct Dia.	CFM	SP
48"	10"	481	0.08
60"	12"	631	0.07
72"	12"	781	0.1
96"	2@10"	1082	0.1

HORIZONTAL PANELS ON COMBINATION SASH		
Hood Width	Sash Width	# of Panels
48"	9-3/4"	4
60"	12-3/4"	4
72"	15-3/4"	4
96"	14-13/16"	6

**FUME HOODS**  
**OBSERVATION2™ CONSTANT VOLUME DOUBLE-FACED BENCH**

**Features**

Double-faced fume hoods are designed to provide the greatest visibility with full viewing side and back glass panels. This allows the instructor or supervisor to spot any hazardous situations that may occur. This hood is suitable for Constant Air Volume (CAV) requirements only. The Observation2™ bench mounted fume hood is supplied with the following standard features:



Hood shown with vertical rising sashes.

- The Observation2 fume hood has been tested to ASHRAE standards at face velocities as low as 60 fpm.
- Powder coated galvanized steel interior liner. Not suitable for highly corrosive situations.
- Available with two separate vertical rising sashes or two combination vertical rising and horizontal sliding sashes with chain and sprocket sash counterbalance systems.
- Low profile, powder coated, type 316 stainless steel hinged airfoil is flush with work surface making it easier to load equipment and simple to clean.
- Secondary spill containment trough along the front edge of work surface provides more protection from hazardous chemical spills.
- Auto sash leveler automatically closes to the 18" height which offers extra protection to the operator.
- Full viewing sash provides a clear and unobstructed side to side view of fume hood interior, with a 36" high viewing area. Narrow post design allows for more usable interior width.
- Combination sashes have glass visor panel on upper portion to restrict opening to 28" high.
- UL/CSA approved fluorescent light fixture complete with bulbs that provide a minimum work surface luminescence of 80 foot candles.
- Two white (one set on each face) UL/CSA approved combination USB charger/duplex receptacles for 120 volt service on one corner post and two white (one set on each face) UL/CSA approved combination light switch/receptacles for 120 volt service provided on the other corner post. Note: USB plug not available with GFI receptacles.
- Snap on front panels allows for easily access to light fixtures.
- All corner posts pre-punched to accept a maximum of 4 front load plumbing fittings per side. If more than 4 plumbing fixtures per side, service controls will need to be base cabinet mounted and services will ship loose. If ordering steel base cabinets, Mott can mount control handles if drawings are supplied.
- Plumbing supply lines provided are crosslinked polyethylene (PEX) for all services except stainless steel tubing provided for natural gas. Black pipe not an available option with this hood.
- Only available with plumbing pre-piped to the top of the hood.
- Exhaust slots on bottom of back panel improved airflow through the fume hood.
- Rectangular duct collar.
- 1/4" laminated safety glass is supplied on center, side and sash panels.
- Fume hood offers limited space to pass pipes from above to below counter. Contact Mott Manufacturing for details.
- If sash stop is required, stainless steel metal sash pin (SASHSTP) will be provided.
- Observation2™ Double-Faced Bench fume hood ships in three pieces to pass through doors.
- UL 1805 Classified.

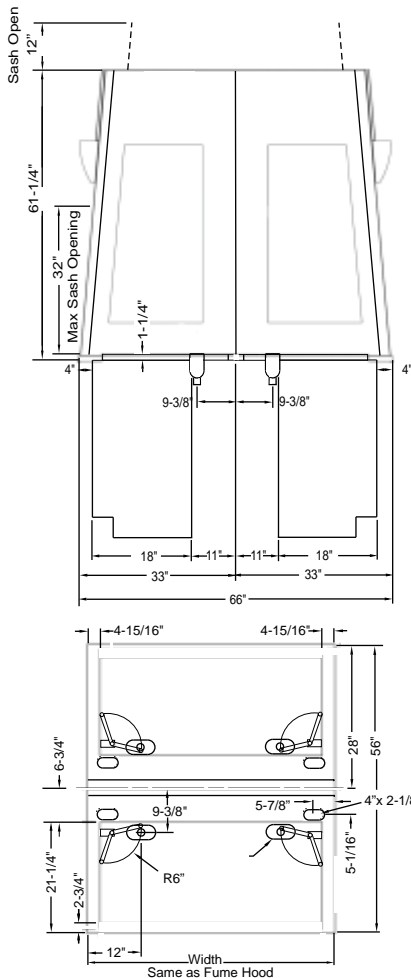

**Note:** 3 piece counter top, contact Mott for epoxy top ordering details.

VERTICAL RAISING SASH (Chain sash system)		COMBINATION SASH (Chain drive system)	HORIZONTAL PANELS ON COMBINATION SASH	
Width	Part Number	Part Number	Sash Width	# of Panels
48"	72CV042-NV	72CV052-NV	10-5/8"	4
60"	73CV042-NV	73CV052-NV	13-5/8"	4
72"	74CV042-NV	74CV052-NV	16-5/8"	4

**OPTIONS**

- H1** Solid End Panels on Left Side of Double-Faced Fume Hood - replaces glass end panels on left with solid end panels when hood is located against a wall.
- H2** Solid End Panels on Right Side of Double-Faced Fume Hood - replaces glass end panels on right with solid end panels when hood is located against a wall.

Exhaust Parameters		100 FPM		60 FPM		100 FPM	
		18" Sash Opening		18" Max Sash Opening		Combo Sash Opens Horizontally Only	
Hood Size	Duct Dia.	CFM	SP	CFM	SP	CFM	SP
48"	6" X 24"	1050	0.4	630	0.3	816	0.35
60"	6" X 24"	1350	0.45	810	0.35	1050	0.4
72"	6" X 24"	1650	0.5	990	0.4	1284	0.45

**Note:** Single duct connection distributes air flow (volume) equally to both sides of hood regardless of sash position. See page C for Double-Faced Bench VAV applications.

EXHAUST TRANSITION		
Hood Width	Item Number	Duct Size
48", 60", 72"	EXT2624	12"

- ∞ Fits over vent collar on Observation2™ fume hoods.
- ∞ Exhaust transitions (rectangular duct to round duct) are available in 20 gauge, Type 316 stainless steel or powder coated galvanized steel and fits over vent collar.
- ∞ One exhaust transition required for Observation2™ CAV Double-Faced model.

*FUME HOODS*  
*OBSERVATION2™ VARIABLE AIR VOLUME DOUBLE-FACED BENCH*

**Features**

Double-faced island fume hoods are designed to provide the greatest visibility with full viewing side and back glass panels. This allows the instructor or supervisor to spot any hazardous situations that may occur. This hood is suitable for Variable Air Volume (VAV) requirements. The Observation2™ bench mounted fume hood is supplied with the following standard features:



Hood shown with vertical rising sashes.

- The Observation2 fume hood has been tested to ASHRAE standards at face velocities as low as 60 fpm.
- Power coated galvanized steel interior liner. Not suited to highly corrosive situations.
- Available with two separate vertical rising sashes or two combination vertical rising and horizontal sliding sashes with chain and sprocket sash counterbalance systems.
- Restricted upper by-pass is standard for VAV applications.
- Low profile, powder coated, type 316 stainless steel hinged airfoil is flush with work surface making it easier to load equipment and simple to clean.
- Secondary spill containment trough along the front edge of work surface provides more protection from hazardous chemical spills.
- Auto sash leveler automatically closes to the 18" height which offers extra protection to the operator.
- Full viewing sash provides a clear and unobstructed side to side view of fume hood interior, with a 36" high viewing area. Narrow post design allows for more usable interior width.
- Combination sashes have glass visor panel on upper portion to restrict opening to 28" high.
- Snap on front panels allows for easily access to light fixtures.
- UL/CSA approved fluorescent light fixture complete with bulbs that provide a minimum work surface luminescence of 80 foot candles.
- Two white (one set on each face) UL/CSA approved combination USB charger/duplex receptacles for 120 volt service on one corner post and two white (one set on each face) UL/CSA approved combination light switch/receptacles for 120 volt service provided on the other corner post. Note: USB plug not available with GFI receptacles.
- All corner posts pre-punched to accept a maximum of 4 front load plumbing fittings per side. If more than 4 plumbing fixtures per side, service controls will need to be base cabinet mounted and services will ship loose. If ordering steel base cabinets, Mott can mount control handles if drawings are supplied.
- Plumbing supply lines provided are crosslinked polyethylene (PEX) for all services except stainless steel tubing provided for natural gas. Black pipe not an available option with this hood.
- Only available with plumbing pre-piped to the top of the hood.
- Exhaust slots on bottom of back panel improved airflow through the fume hood.
- Two rectangular duct collars and divided plenums.
- 1/4" laminated safety glass is supplied on center, side and sash panels.
- Fume hood offers limited space to pass pipes from above to below counter. Contact Mott Manufacturing for details.
- If sash stop is required, stainless steel metal sash pin (SASHSTP) will be provided.
- Observation2™ Double-Faced Bench fume hood ships in three pieces to pass through doors.
- UL 1805 Classified.

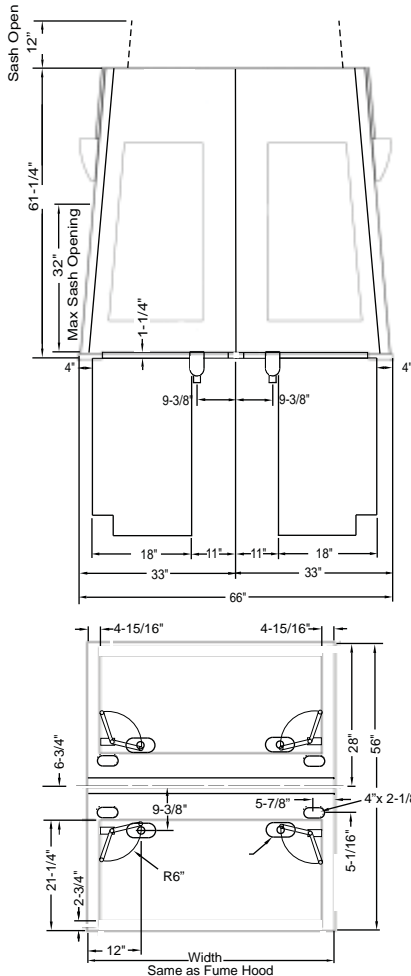

**Note:** 3 piece counter top, contact Mott for epoxy top ordering details.

VERTICAL RAISING SASH (Chain sash system)		COMBINATION SASH (Chain drive system)	HORIZONTAL PANELS ON COMBINATION SASH	
Width	Part Number	Part Number	Sash Width	# of Panels
48"	72CA042-NV	72CA052-NV	10-5/8"	4
60"	73CA042-NV	73CA052-NV	13-5/8"	4
72"	74CA042-NV	74CA052-NV	16-5/8"	4

**OPTIONS**

- H1** Solid End Panels on Left Side of Double-Faced Fume Hood - replaces glass end panels on left with solid end panels when hood is located against a wall.
- H2** Solid End Panels on Right Side of Double-Faced Fume Hood - replaces glass end panels on right with solid end panels when hood is located against a wall.

Exhaust Parameters		100 FPM		60 FPM		100 FPM	
		18" Sash Opening		18" Max Sash Opening		Combo Sash Opens Horizontally Only	
Hood Size	Duct Dia.	CFM	SP	CFM	SP	CFM	SP
48"	2 @ 3" X 24"	2 @ 525	2 @ 0.4	2 @ 315	2 @ 0.3	2 @ 408	2 @ 0.35
60"	2 @ 3" X 24"	2 @ 675	2 @ 0.45	2 @ 405	2 @ 0.35	2 @ 525	2 @ 0.4
72"	2 @ 3" X 24"	2 @ 825	2 @ 0.5	2 @ 495	2 @ 0.4	2 @ 642	2 @ 0.45

**Note:** See page B for Double-Faced Bench CAV applications.

EXHAUST TRANSITION		
Hood Width	Item Number	Duct Size
48", 60", 72"	EXT0324	10"

- ∞ Fits over the vent collars on Observation2™ fume hoods.
- ∞ Exhaust transitions (rectangular duct to round duct) are available in 20 gauge, Type 316 stainless steel or powder coated galvanized steel and fits over vent collar.
- ∞ Two exhaust transitions are required for the Observation2™ VAV Double-Faced model.

**QUALITY BY DESIGN**

*FUME HOODS*  
*OBSERVATION2™ CONSTANT VOLUME SINGLE-FACED BENCH*

**Features**

This single-faced fume hood is designed to provide the greatest visibility with full viewing side panels. This allows the instructor or supervisor to spot any hazardous situations that may occur. This hood is suitable for Constant Air Volume (CAV) requirements only. The Observation2™ bench mounted fume hood is supplied with the following standard features:



Hood shown with option GB (glass back viewing panel) and vertical rising sash.

- The Observation2 fume hood has been tested to ASHRAE standards at face velocities as low as 60 fpm.
- Powder coated galvanized steel interior liner. Not suited to highly corrosive situations.
- Available with vertical rising sash or combination vertical rising and horizontal sliding sashes with chain and sprocket sash counterbalance system.
- Low profile, powder coated, type 316 stainless steel hinged airfoil is flush with work surface making it easier to load equipment and simple to clean.
- Secondary spill containment trough along the front edge of work surface provides more protection from hazardous chemical spills.
- Auto sash leveler automatically closes to the 18" height which offers extra protection to the operator.
- Full viewing sash provides a clear and unobstructed side to side view of fume hood interior, with a 36" high viewing area. Narrow post design allows for more usable interior width.
- Combination sashes have glass visor panel on upper portion to restrict opening to 28" high.
- UL/CSA approved fluorescent light fixture complete with bulbs that provide a minimum work surface luminescence of 80 foot candles.
- One white UL/CSA approved combination USB charger/duplex receptacle for 120 volt service on one corner post and one white UL/CSA approved combination light switch/receptacle for 120 volt service provided on other corner post. Note: USB plug not available with GFI receptacles.
- Snap on front panel allows for easily access to light fixtures.
- Two corner posts pre-punched to accept a maximum of 4 front load plumbing fittings per side. If more than 4 plumbing fixtures per side, service controls will need to be base cabinet mounted and services will ship loose. If ordering steel base cabinets, Mott can mount control handles if drawings are supplied.
- Plumbing supply lines provided are crosslinked polyethylene (PEX) for all services except stainless steel tubing provided for natural gas. Black pipe not an available option with this hood.
- Only available with plumbing pre-piped to the top of the hood.
- Rectangular duct collar.
- Exhaust slots on bottom of back panel improves airflow through the hood.
- 1/4" laminated safety glass is supplied on side and sash panels. Optional glass back viewing panel available, use option code GB.
- Fume hood offers limited space to pass pipes from above to below counter. Contact Mott Manufacturing for details.
- If sash stop is required, stainless steel metal sash pin (SASHSTP) will be provided.
- UL 1805 Classified.

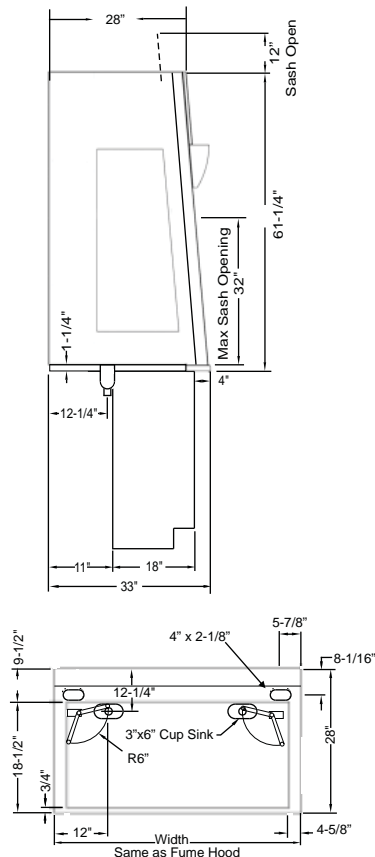

VERTICAL RAISING SASH (Chain sash system)		COMBINATION SASH (Chain drive system)	HORIZONTAL PANELS ON COMBINATION SASH	
Width	Part Number	Part Number	Sash Width	# of Panels
48"	72CV040-NV	72CV050-NV	10-5/8"	4
60"	73CV040-NV	73CV050-NV	13-5/8"	4
72"	74CV040-NV	74CV050-NV	16-5/8"	4

**OPTIONS**

- H3** Solid End Panel on Left Side of Single-Faced Fume Hood - Replaces glass end panel on left with solid end panel when hood is located against a wall.
- H4** Solid End Panel on Right Side of Single-Faced Fume Hood - Replaces glass end panel on right with solid end panel when hood is located against a wall.
- GB** Glass Back Panel - Replaces solid back panel with glass.

Exhaust Parameters		100 FPM		60 FPM		100 FPM	
		18" Sash Opening		18" Max Sash Opening		Combo Sash Opens Horizontally Only	
Hood Size	Duct Dia.	CFM	SP	CFM	SP	CFM	SP
48"	3" X 24"	525	0.4	315	0.3	408	0.35
60"	3" X 24"	675	0.45	405	0.35	525	0.4
72"	3" X 24"	825	0.5	495	0.4	642	0.45

**Note:** See page E for Single-Faced Bench VAV applications.

EXHAUST TRANSITION		
Hood Width	Item Number	Duct Size
48", 60", 72"	EXT0324	10"

- ∞ Fits over vent collar on Observation2™ fume hoods.
- ∞ Exhaust transitions (rectangular duct to round duct) are available in 22 gauge, Type 304 stainless steel or powder coated galvanized steel and fits over vent collar.
- ∞ One exhaust transition is required for the Observation2™ CAV Single-Faced model.

**Note:** 2 piece top, contact Mott for epoxy top ordering details.



*FUME HOODS*  
*OBSERVATION2™ VARIABLE AIR VOLUME SINGLE-FACED BENCH*

**Features**

This single-faced fume hood is designed to provide the greatest visibility with full viewing side panels. This allows the instructor or supervisor to spot any hazardous situations that may occur. This hood is suitable for Variable Air Volume (VAV) requirements. The Observation2™ bench mounted fume hood is supplied with the following standard features:



Hood shown with option GB (glass back viewing panel) and vertical rising sash.

- The Observation2 fume hood has been tested to ASHRAE standards at face velocities as low as 60 fpm.
- Powder coated galvanized steel interior liner. Not suited to highly corrosive situations.
- Available with vertical rising sash or combination vertical rising and horizontal sliding sashes with chain and sprocket sash counterbalance system.
- Restricted upper by-pass is standard for VAV applications.
- Low profile, powder coated, type 316 stainless steel hinged airfoil is flush with work surface making it easier to load equipment and simple to clean.
- Secondary spill containment trough along the front edge of work surface provides more protection from hazardous chemical spills.
- Auto sash leveler automatically closes to the 18" height which offers extra protection to the operator.
- Full viewing sash provides a clear and unobstructed side to side view of fume hood interior, with a 36" high viewing area. Narrow post design allows for more usable interior width.
- Combination sashes have glass visor panel on upper portion to restrict opening to 28" high.
- UL/CSA approved fluorescent light fixture complete with bulbs that provide a minimum work surface luminescence of 80 foot candles.
- One white UL/CSA approved combination USB charger/duplex receptacle for 120 volt service on one corner post and one white UL/CSA approved combination light switch/receptacle for 120 volt service provided on other corner post. Note: USB plug not available with GFI receptacles.
- Snap on front panel allows for easily access to light fixtures.
- Two corner posts pre-punched to accept a maximum of 4 front load plumbing fittings per side. If more than 4 plumbing fixtures per side, service controls will need to be base cabinet mounted and services will ship loose. If ordering steel base cabinets, Mott can mount control handles if drawings are supplied.
- Plumbing supply lines provided are crosslinked polyethylene (PEX) for all services except stainless steel tubing provided for natural gas. Black pipe not an available option with this hood.
- Only available with plumbing pre-piped to the top of the hood.
- Rectangular duct collar.
- Exhaust slots on bottom of back panel improves airflow through the hood.
- 1/4" laminated safety glass is supplied on side and sash panels. Optional glass back viewing panel available, use option code GB.
- Fume hood offers limited space to pass pipes from above to below counter. Contact Mott Manufacturing for details.
- If sash stop is required, stainless steel metal sash pin (SASHSTP) will be provided.
- UL 1805 Classified.

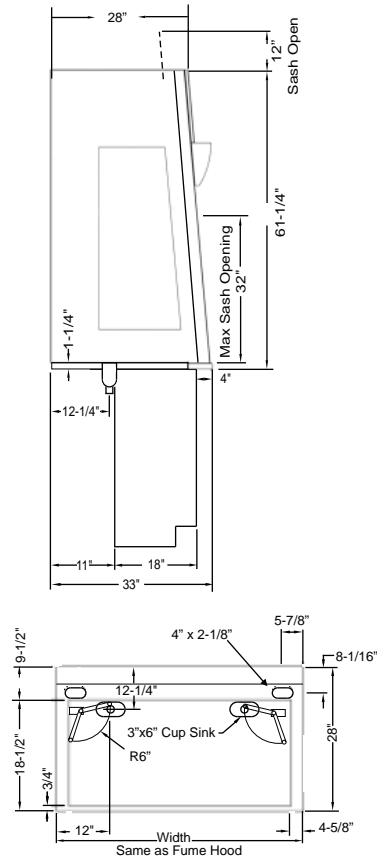

VERTICAL RAISING SASH (Chain sash system)		COMBINATION SASH (Chain drive system)		HORIZONTAL PANELS ON COMBINATION SASH	
Width	Part Number	Part Number	Sash Width	# of Panels	
48"	72CA040-NV	72CA050-NV	10-5/8"	4	
60"	73CA040-NV	73CA050-NV	13-5/8"	4	
72"	74CA040-NV	74CA050-NV	16-5/8"	4	

**OPTIONS**

- H3** Solid End Panel on Left Side of Single-Faced Fume Hood - Replaces glass end panel on left with solid end panel when hood is located against a wall.
- H4** Solid End Panel on Right Side of Single-Faced Fume Hood - Replaces glass end panel on right with solid end panel when hood is located against a wall.
- GB** Glass Back Panel - Replaces solid back panel with glass.

Exhaust Parameters		100 FPM		60 FPM		100 FPM	
		18" Sash Opening		18" Max Sash Opening		Combo Sash Opens Horizontally Only	
Hood Size	Duct Dia.	CFM	SP	CFM	SP	CFM	SP
48"	3" X 24"	525	0.4	315	0.3	408	0.35
60"	3" X 24"	675	0.45	405	0.35	525	0.4
72"	3" X 24"	825	0.5	495	0.4	642	0.45

**Note:** See page D for Single-Faced Bench CAV applications.

EXHAUST TRANSITION		
Hood Width	Item Number	Duct Size
48", 60", 72"	EXT0324	10"

- ∞ Fits over vent collar on Observation2™ fume hoods.
- ∞ Exhaust transitions (rectangular duct to round duct) are available in 22 gauge, Type 304 stainless steel or powder coated galvanized steel and fits over vent collar.
- ∞ One exhaust transition is required for the Observation2™ VAV Single-Faced model.

Note: 2 piece counter top, contact Mott for epoxy top ordering details.

*FUME HOODS*  
*OBSERVATION™ CONSTANT VOLUME ISLAND BENCH*

**Features**

The double-faced island fume hoods are designed to provide the greatest visibility with full viewing side and back glass panels. This allows the teacher or supervisor to spot any hazardous situations that may occur. This hood is suitable for Constant Air Volume (CAV) requirements only. The Observation™ bench mounted fume hood is supplied with the following standard features:



- Not suitable for highly corrosive situations.
- Two separate vertical rising sashes.
- Epoxy coated steel interior liner.
- Low profile powder coated, type 316 stainless steel hinged airfoil is flush with work surface to provide easy access by keeping the work surface open to accommodate equipment and procedures and for easy cleaning.
- Secondary spill containment trough along the front edge of work surface provides more protection from hazardous chemical spills.
- Auto sash leveler automatically closes to the 18" height which decreases exhaust air and offers extra protection to the operator.
- Full viewing sash provides a clear and unobstructed side to side view of fume hood interior, with a 36" high viewing area.
- A UL/CSA approved fluorescent light fixture complete with bulbs that provide a minimum work surface luminescence of 80 foot candles. Light switch is base cabinet mounted and shipped loose. If ordering metal base cabinets, Mott can mount switch if drawings are supplied.
- Hinged front panel allows for easily access to light fixtures.
- Inside corner posts pre-punched to accept a maximum of 4 plumbing fittings per side. Service controls are base cabinet mounted and are shipped loose. If ordering metal base cabinets, Mott can mount control handles if drawings are supplied.
- Exhaust slots on bottom of back panel improved airflow through the fume hood.
- Narrow post design allows for more usable interior width.
- Rectangular duct collar.
- 1/4" laminated safety glass is supplied on back, side and sash panels.
- Fume hood offers limited service space and does not allow for waste vents.
- If sash stop is required stainless steel metal sash pin (SASHSTP) will be provided.
- Add option S2 for a restricted by-pass damper.
- Plumbing supply lines must be located below the bench and must be 3/8" OD soft copper lines only.
- Observation™ Island Bench fume hood ships in three pieces to pass through doors.

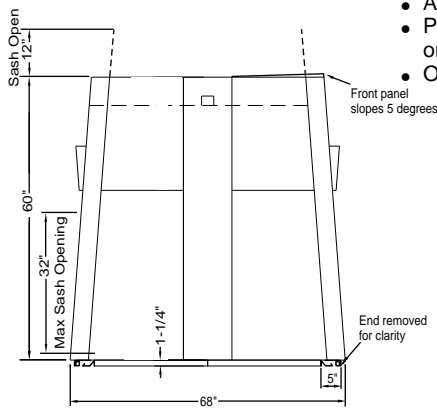

VERTICAL RAISING SASH (Cable sash system)	
Width	Part Number
48"	72CV002
60"	73CV002
72"	74CV002

**OPTIONS**

- H1** Solid End Panels on Left Side of Double-Faced Fume Hood - replaces glass end panels on left with solid end panels when hood is located against a wall.
- H2** Solid End Panels on Right Side of Double-Faced Fume Hood - replaces glass end panels on right with solid end panels when hood is located against a wall.

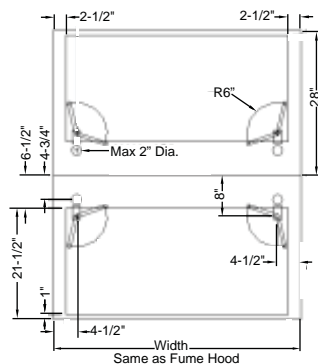

Exhaust Parameters		100 FPM	
		18" Sash Opening Both Sides	
Hood Size	Duct Dia.	CFM	SP
48"	6"X24"	1100	0.4
60"	6"X24"	1400	0.45
72"	6"X24"	1700	0.5

**Note:** Single duct connection distributes air flow (volume) equally to both sides of hood regardless of sash position. See page P35 for VAV applications.

EXHAUST TRANSITION		
Hood Width	Item Number	Duct Size
48", 60", 72"	EXT2624	12"

- ∞ Fits over vent collar on Observation™ fume hoods.
- ∞ Exhaust transitions (rectangular duct to round duct) are available in 20 gauge, Type 316 stainless steel or powder coated galvanized steel and fits over vent collar.
- ∞ One exhaust transition required for Observation™ CAV island model.

*FUME HOODS*  
*OBSERVATION™ VARIABLE AIR VOLUME ISLAND BENCH*

**Features**

The double-faced island fume hoods are designed to provide the greatest visibility with full viewing side and back glass panels. This allows the teacher or supervisor to spot any hazardous situations that may occur. This hood is suitable for Variable Air Volume (VAV) requirements. The Observation™ bench mounted fume hood is supplied with the following standard features:



- Not suited to highly corrosive situations.
- Two separate vertical rising sashes.
- Epoxy coated steel interior liner.
- Low profile powder coated, type 316 stainless steel hinged airfoil is flush with work surface to provide easy access by keeping the work surface open to accommodate equipment and procedures and for easy cleaning.
- Secondary spill containment trough along the front edge of work surface provides more protection from hazardous chemical spills.
- Auto sash leveler automatically closes to the 18" height which decreases exhaust air and offers extra protection to the operator.
- Full viewing sash provides a clear and unobstructed side to side view of fume hood interior, with a 36" high viewing area.
- A UL/CSA approved fluorescent light fixture complete with bulbs that provide a minimum work surface luminescence of 80 foot candles. Light switch is base cabinet mounted and shipped loose. If ordering metal base cabinets, Mott can mount switch if drawings are supplied.
- Hinged front panel allows for easily access to light fixtures.
- Inside corner posts pre-punched to accept a maximum of 4 plumbing fittings per side. Service controls are base cabinet mounted and are shipped loose. If ordering metal base cabinets, Mott can mount control handles if drawings are supplied.
- Exhaust slots on bottom of back panel improved airflow through the fume hood.
- Narrow post design allows for more usable interior width.
- Two rectangular duct collars and divided plenums.
- 1/4" laminated safety glass is supplied on back, side and sash panels.
- Fume hood offers limited service space and does not allow for waste vents.
- If sash stop is required stainless steel metal sash pin (SASHSTP) will be provided.
- Add option S2 for a restricted by-pass damper.
- Plumbing supply lines must be located below the bench and must be 3/8" OD soft copper lines only.
- Observation™ Island Bench fume hood ships in three pieces to pass through doors.

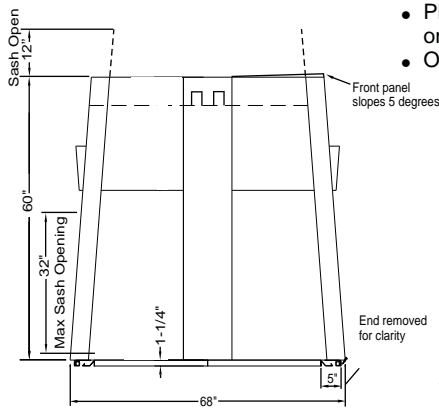

VERTICAL RAISING SASH (Cable sash system)	
Width	Part Number
48"	72CA002
60"	73CA002
72"	74CA002

**OPTIONS**

- H1** Solid End Panels on Left Side of Double-Faced Fume Hood - replaces glass end panels on left with solid end panels when hood is located against a wall.
- H2** Solid End Panels on Right Side of Double-Faced Fume Hood - replaces glass end panels on right with solid end panels when hood is located against a wall.

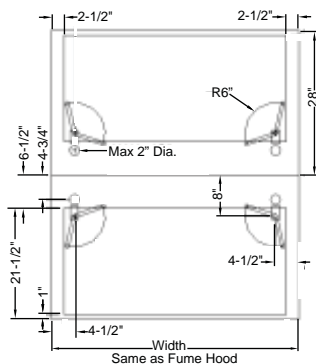

Exhaust Parameters		100 FPM 18" Sash Opening Each Side	
		CFM	SP
Hood Size	Duct Dia.	2 @ 550	0.4
48"	2 @ 3"X24"	2 @ 700	0.45
60"	2 @ 3"X24"	2 @ 850	0.5
72"	2 @ 3"X24"		

**Note:** See page P34 for CAV applications.

EXHAUST TRANSITION		
Hood Width	Item Number	Duct Size
48", 60", 72"	EXT0324	10"

- ∞ Fits over the vent collars on Observation™ fume hoods.
- ∞ Exhaust transitions (rectangular duct to round duct) are available in 20 gauge, Type 316 stainless steel or powder coated galvanized steel and fits over vent collar.
- ∞ Two exhaust transitions are required for the Observation™ VAV island model.



*FUME HOODS*  
*OBSERVATION™ SINGLE-FACED BENCH*

**Features**

This single-faced fume hood is designed to provide the greatest visibility with full viewing side panels. This allows the teacher or supervisor to spot any hazardous situations that may occur. This hood is designed to meet most laboratory Constant Air Volume (CAV) or Variable Air Volume (VAV) requirements. For VAV use add option S2.

The Observation™ bench mounted fume hood is supplied with the following standard features:



- Not suited to highly corrosive situations.
- Vertical rising sash.
- Epoxy coated steel interior liner.
- Low profile powder coated, type 316 stainless steel hinged airfoil is flush with work surface to provide easy access by keeping the work surface open to accommodate equipment and procedures and for easy cleaning.
- Secondary spill containment trough along the front edge of work surface provides more protection from hazardous chemical spills.
- Auto sash leveler automatically closes to the 18" height which decreases exhaust air and offers extra protection to the operator.
- Full viewing sash provides a clear and unobstructed side to side view of fume hood interior, with a 36" high viewing area.
- Optional glass back viewing panel available, use option code GB.
- A UL/CSA approved fluorescent light fixture complete with bulbs that provide a minimum work surface luminescence of 80 foot candles. Light switch is base cabinet mounted and shipped loose. If ordering metal base cabinets, Mott can mount switch if drawings are supplied.
- Hinged front panel allows for easily access to light fixtures.
- Inside corner posts pre-punched to accept a maximum of 4 plumbing fittings per side. Service controls are base cabinet mounted and are shipped loose. If ordering metal base cabinets, Mott can mount control handles if drawings are supplied.
- Rectangular duct collar.
- Narrow post design allows for more usable interior width.
- Exhaust slots on bottom of back panel improves airflow through the hood.
- 1/4" laminated safety glass is supplied on back, side and sash panels.
- Fume hood offers limited service space and does not allow for waste vents.
- If sash stop is required stainless steel metal sash pin (SASHSTP) will be provided.
- Add option S2 for a restricted by-pass damper.
- Plumbing supply lines must be located below the bench and must be 3/8" OD soft copper lines only.

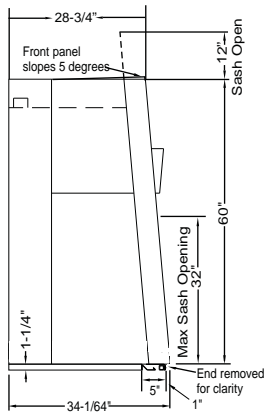

VERTICAL RAISING SASH (Cable sash system)	
Width	Part Number
48"	72CV000
60"	73CV000
72"	74CV000

**OPTIONS**

- H3** Solid End Panel on Left Side of Single-Faced Fume Hood - Replaces glass end panel on left with solid end panel when hood is located against a wall.
- H4** Solid End Panel on Right Side of Single-Faced Fume Hood - Replaces glass end panel on right with solid end panel when hood is located against a wall.
- GB** Glass Back Panel - Replaces solid back panel with glass.

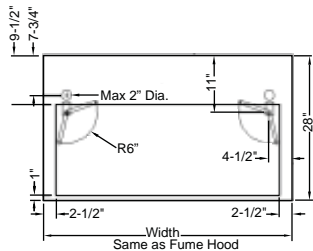

Exhaust Parameters		100 FPM 18" Sash Opening	
		CFM	SP
Hood Size	Duct Dia.		
48"	3" X 24"	550	0.4
60"	3" X 24"	700	0.45
72"	3" X 24"	850	0.5

EXHAUST TRANSITION		
Hood Width	Item Number	Duct Size
48", 60", 72"	EXT0324	10"

- ∞ Fits over vent collar on Observation™ fume hoods.
- ∞ Exhaust transitions (rectangular duct to round duct) are available in 22 gauge, Type 304 stainless steel or powder coated galvanized steel and fits over vent collar.

*FUME HOODS  
SELECT VENTILATED WORK STATION - VERTICAL SASH*

**Features**

This cost effective ventilation work station is designed to meet the requirements of some school laboratory applications. Designed to mount on a 30" deep counter top. This hood is designed to meet most laboratory Constant Air Volume (CAV) or Variable Air Volume (VAV) requirements. For VAV use add option S2.

The Select bench mounted work station is supplied with the following standard features:

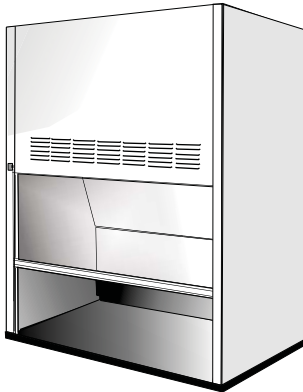

- A vertical rising sash.
- For variable air volume (VAV) requirements, use optional Restricted By-Pass Plate (option code S2).
- 2" wide thin wall construction.
- An automatic compensating upper by-pass.
- Sash closes to within 1" of the counter top.
- A UL/CSA approved fluorescent light fixture complete with bulbs that provide a minimum work surface luminescence of 80 foot candles and a corner post mounted UL/CSA approved switch.
- Removable exterior side panels.
- Not CSA or UL approved as a unit.

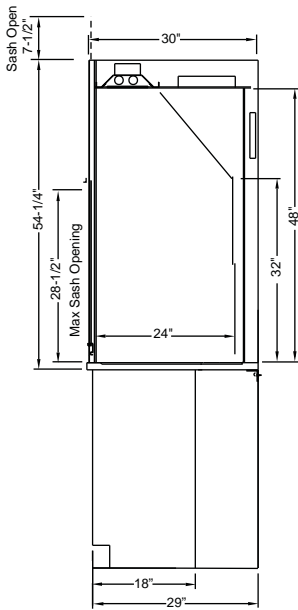

VERTICAL RAISING SASH (Cable sash system)	
Width	FRP
36"	VWS0036
48"	VWS0048
60"	VWS0060
72"	VWS0072
96"	VWS0096
1000mm	VWS000B
1513mm	VWS000C

Exhaust Parameters		80 FPM		100 FPM		80 FPM		100 FPM	
		28-1/2 Max Sash Opening		28-1/2 Max Sash Opening		18 Max Sash Opening		18 Max Sash Opening	
Hood Size	Duct Dia.	CFM	SP	CFM	SP	CFM	SP	CFM	SP
36"	10"	507	0.09	633	0.14	320	0.04	400	0.05
48"	10"	697	0.17	871	0.25	440	0.06	550	0.1
60"	12"	887	0.13	1109	0.2	560	0.05	700	0.08
72"	12"	1077	0.19	1346	0.3	680	0.08	850	0.12
96"	2@10"	1457	0.18	1821	0.28	920	0.07	1150	0.12
1000mm	10"	560	0.1	700	0.17	354	0.05	442	0.07
1513mm	12"	879	0.13	1099	0.2	555	0.05	693	0.08

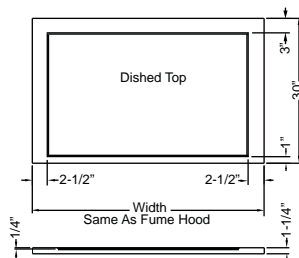

Typical ventilated work station work top.

*FUME HOODS  
WALL AND ISLAND CANOPIES*

**Features**

Exhaust canopies are primarily used to exhaust steam, odors and heat. In a work area where the expense and capabilities of a fume hood are not justified.

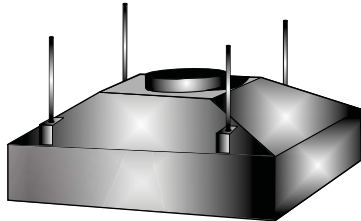

- Available in either wall or island configurations.
- Integrally welded construction.
- Integral continuous condensation catch edge.
- Integral duct stub.
- Steel rod suspension.
- Standard fixed baffle (not available with fluorescent light option).
- Optional UL/CSA approved fluorescent light fixture complete with bulbs.
- Several materials are available.

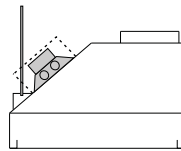

**Option E6 - Fluorescent Light**

- Complete with a light enclosure.
- Fixed baffle not available when ordering fluorescent light.
- Wire from light to junction box is not concealed.

**WALL CANOPY HOODS**

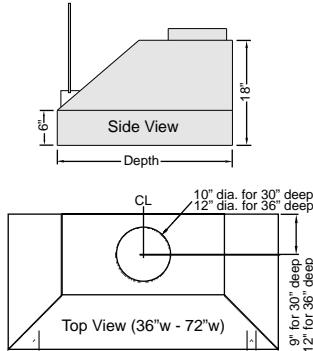

WALL CANOPY HOODS - 18" HIGH							
Width	Duct Dia.	30" Deep			36" Deep		
		Painted	304 S/S	316 S/S	Painted	304 S/S	316 S/S
36"	10"	CWP1236	CWR1236	CWS1236	CWP1336	CWR1336	CWS1336
48"	10"	CWP1248	CWR1248	CWS1248	CWP1348	CWR1348	CWS1348
60"	12"	CWP1260	CWR1260	CWS1260	CWP1360	CWR1360	CWS1360
72"	12"	CWP1272	CWR1272	CWS1272	CWP1372	CWR1372	CWS1372
96"	2 @ 10"	CWP1296	CWR1296	CWS1296	CWP1396	CWR1396	CWS1396
1000mm	10"	CWP120A	CWR120A	CWS120A	CWP130A	CWR130A	CWS130A
1513mm	12"	CWP120B	CWR120B	CWS120B	CWP130B	CWR130B	CWS130B
2000mm	12"	CWP120C	CWR120C	CWS120C	CWP130C	CWR130C	CWS130C

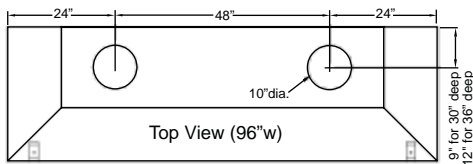

**ISLAND CANOPY HOODS**

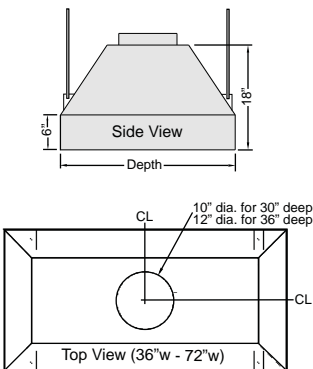

ISLAND CANOPY HOODS - 18" HIGH								
Width	Duct Dia.		30" Deep			36" Deep		
	30" Deep	36" Deep	Painted	304 S/S	316 S/S	Painted	304 S/S	316 S/S
36"	10"	10"	CIP1236	CIR1236	CIS1236	CIP1336	CIR1336	CIS1336
48"	10"	10"	CIP1248	CIR1248	CIS1248	CIP1348	CIR1348	CIS1348
60"	12"	12"	CIP1260	CIR1260	CIS1260	CIP1360	CIR1360	CIS1360
72"	12"	12"	CIP1272	CIR1272	CIS1272	CIP1372	CIR1372	CIS1372
96"	2 @ 10"	2 @ 10"	CIP1296	CIR1296	CIS1296	CIP1396	CIR1396	CIS1396
1000mm	10"	10"	CIP120A	CIR120A	CIS120A	CIP130A	CIR130A	CIS130A
1513mm	12"	12"	CIP120B	CIR120B	CIS120B	CIP130B	CIR130B	CIS130B
2000mm	12"	12"	CIP120C	CIR120C	CIS120C	CIP130C	CIR130C	CIS130C

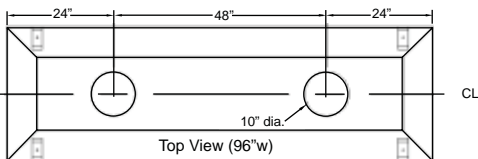

*FUME HOODS  
SPRAY BOOTHS*

**Features**

This spray booth is designed for simple nontoxic exhaust operations. Designed to mount on a 24" deep counter top. The spray booth bench mounted hood is supplied with the following standard features:

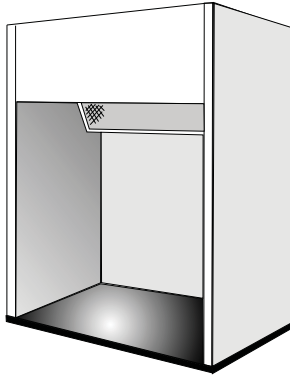

- 2" wide thin wall construction.
- 18 gauge steel construction with our thermosetting laboratory grade powder coating.
- Constant exhaust volume.
- Fiberglass air filter diffuser to promote more even face velocity.
- Vapor proof fluorescent light fixture and junction box.
- 24" models have incandescent light.
- Designed to wire to a remotely mounted light switch supplied by others.
- Not CSA or UL approved as a unit.

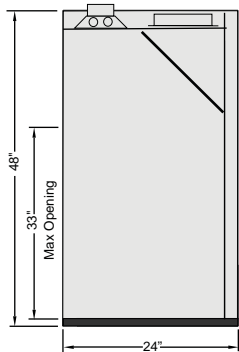

SPRAY BOOTH	
Width	Item Number
24"	8101000
30"	8201000
36"	8301000
48"	8401000
60"	8501000

Exhaust Parameters		100 FPM 33" Max Opening	
		CFM	SP
Hood Size	Duct Dia.		
24"	10"	505	0.05
30"	10"	642	0.80
36"	10"	780	0.80
48"	10"	1055	1.00
60"	10"	1330	1.00

*FUME HOODS*  
*FUME HOOD ELECTRICAL SERVICES*

**Parts**

Note: Specify NEMA Code when ordering.

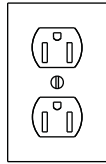

125 volts - 15 amps  
Polarized  
3 Grounding wire type  
NEMA 5-15R

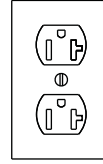

125 volts - 20amps  
Polarized  
3 Grounding wire type  
NEMA 5-20R

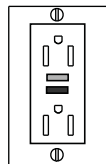

125 volts - 15 amps  
GFI Duplex  
3 Grounding wire type  
NEMA 5-15R

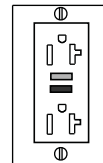

125 volts - 20 amps  
GFI Duplex  
3 Grounding wire type  
NEMA 5-20R

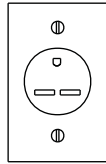

250 volts - 30 amps  
3 Grounding wire type  
NEMA 6-30R

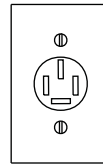

208/120 volts 3 Phase - 20 amps  
NEMA 18-20R

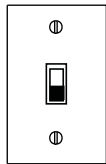

Light Switch 15 or 20 amp

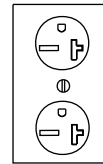

250 volts - 20 amps  
3 Grounding wire type  
NEMA 6-20R

Note: Also used for single phase 208V applications

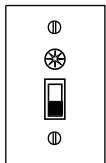

Fan Switch with Pilot Light 120 or 240 volts  
Note: This switch requires a heater to be installed. Heater must be selected to suit the load and is not included.

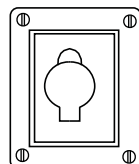

Explosion Resistant Receptacle  
120 volts-20 amps  
3-pole

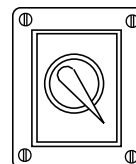

Explosion Resistant Switch  
120 volts-20 amps

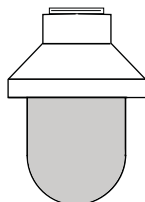

Explosion Resistant Light  
120 volt- 60 Hz

*FUME HOODS*  
*FUME HOOD FIXTURES*

**Fume Hood Angled Hose Cock**

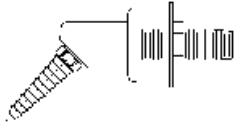

These fixtures are to be ordered if you require fixtures to be shipped loose.

**Item Number**

L022WSA

- Wall mounted valve unit color coded to match the valve handle.

**Fume Hood Remote Control Valves**

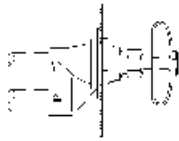

**Item Number**

L740N-PH

- Front access valve with color coded handle for gas, vacuum and air.
- C.G.A. & A.G.A. Approved for gas.

**Item Number**

L740W-PH

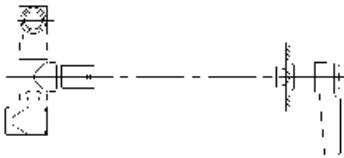

**Item Number**

L4285B

- Rod controlled valve with color coded index button.
- C.G.A. & A.G.A. Approved for gas.

**Fume Hood Gooseneck Faucet**



**Item Number**

L174VB-WSA

- Wall mounted rigid swivel gooseneck faucet color coded to match remote control valve handle.
- Complete with serrated tip and atmospheric vacuum breaker.



**Item Number**

L174WSA

- Wall mounted rigid swivel faucet color coded to match remote control valve handle.
- Complete with serrated tip



**Item Number**

L112

- Exposed atmospheric vacuum breaker for mounting to front corner panel.



**Item Number**

L100

- Atmospheric vacuum breaker to locate on roof of hood.



*FUME HOODS*  
*FUME HOOD ACCESSORIES*

**Audio/Visual Fume Hood Alarm**

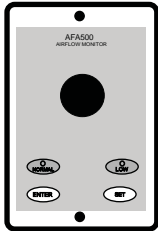

**Item Number**

ALARM05

- The fume hood velocity alarm is used to make sure that the face velocity does not drop below an unsafe level.

**Audio/Visual Fume Hood Alarm**

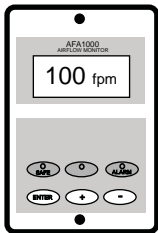

**Item Number**

ALARM04

- The fume hood velocity alarm is used to make sure that the face velocity does not drop below an unsafe level.
- Digital display of face velocity.

**Magnehelic Differential Pressure Gage**

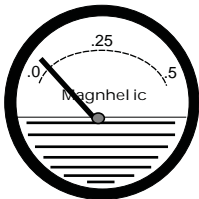

**Item Number**

MAGGAGE

- Used to monitor pressure drop across induct filters. Factory installed in upper front panel. Tubing connections made in field.

**Plastic Sash Stop**



**Item Number**

PLSHSTP

- The sash stop is designed to stop the sash at a pre-determined height.
- Can be manually overridden for apparatus setup.
- Sash stop is placed behind sash handle.
- Standard when option code S3 or S4 are selected .

**Stainless Steel Sash Stop**

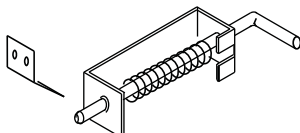

**Item Number**

SASHSTP

- The sash stop is designed to stop the sash at a pre determined height.
- Can be manually overridden for apparatus setup.
- Sash stop is hidden behind sash handle when factory installed.
- Optional only when noted.



### FUME HOODS FUME HOOD ACCESSORIES

#### Furring Panels

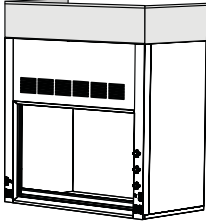

- Fume hood furring panels are used to close off the area between the top of a fume hood and the ceiling.
- Furring panels may be ordered with only one side panel or both.
- Based on 108" ceiling height.
- Furring panel is 19" high.
- Suitable for 32-5/8" deep Pro or SafeGuard™ hood.

Width	Front & Side Panel			Front Only
	Both	Left	Right	
36"	FPS9036	FPL9036	FPR9036	FPF9036
48"	FPS9048	FPL9048	FPR9048	FPF9048
60"	FPS9060	FPL9060	FPR9060	FPF9060
72"	FPS9072	FPL9072	FPR9072	FPF9072
96"	FPS9096	FPL9096	FPR9096	FPF9096
120"	FPS900L	FPL900L	FPR900L	FPF900L
144"	FPS900H	FPL900H	FPR900H	FPF900H

#### Furring Panels with Hinged Access

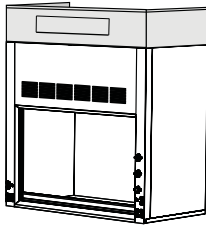

- Fume hood furring panels are used to close off the area between the top of a fume hood and the ceiling.
- Furring panels may be ordered with only one side panel or both.
- Based on 108" ceiling height.
- Furring panel is 19" high. Hinged access panel is 12" high.
- Suitable for 32-5/8" deep Pro or SafeGuard™ hood.

Width	Front & Side Panel			Front Only
	Both	Left	Right	
36"	FPS9236	FPL9236	FPR9236	FPF9236
48"	FPS9248	FPL9248	FPR9248	FPF9248
60"	FPS9260	FPL9260	FPR9260	FPF9260
72"	FPS9272	FPL9272	FPR9272	FPF9272
96"	FPS9296	FPL9296	FPR9296	FPF9296
120"	FPS920L	FPL920L	FPR920L	FPF920L
144"	FPS920H	FPL920H	FPR920H	FPF920H

#### Double Sided Demonstration Furring Panels

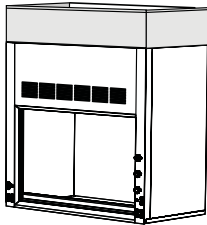

- Suitable for 35-1/4" deep double sided Demonstration fume hoods.
- Furring panels for double sided Demonstration Fume Hoods are used to close off the area between the top of a fume hood and the ceiling.
- Based on 108" ceiling height.
- Furring panels are 19" high X 35-1/4" deep.
- If Access Panel option is chosen one access panel is supplied (not shown).

Width	Without Access Panel	With Access Panel	With Hinged Access Panel
36"	FPD9036	FPD9136	FPD9236
48"	FPD9048	FPD9148	FPD9248
60"	FPD9060	FPD9160	FPD9260
72"	FPD9072	FPD9172	FPD9272
96"	FPD9096	FPD9196	FPD9296

#### Pro Series Furring Panels with Finished Back

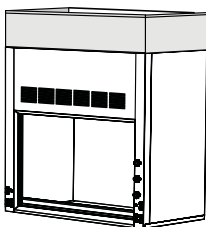

- Suitable for 32-5/8" deep Pro Series fume hoods with finished backs.
- Fume hood furring panels are used to close off the area between the top of the hood and ceiling.
- Based on 108" ceiling height.
- Furring panels are 19" high X 32-5/8" deep.
- If Access Panel option is chosen one access panel is supplied (not shown).

Width	Without Access Panel	With Access Panel	With Hinged Access Panel
36"	FPP9036	FPP9136	FPP9236
48"	FPP9048	FPP9148	FPP9248
60"	FPP9060	FPP9160	FPP9260
72"	FPP9072	FPP9172	FPP9272
96"	FPP9096	FPP9196	FPP9296

#### Observation™ Island Furring Panels

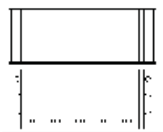

- Fume hood furring panels are used to close off the area between the top of a fume hood and the ceiling.
- Based on 108" ceiling height.
- Furring panel is 12" high, 54-3/4" deep.

Width	4 Sided Furring Panel	Front & Back Only
36"	FPB9036	FPB9136
48"	FPB9048	FPB9148
60"	FPB9060	FPB9160
72"	FPB9072	FPB9172
96"	FPB9096	FPB9196

**Recommendation For Installation:** When ceilings are suspended, it is recommended that the furring panel assembly extend to the underside of the ceiling. The floating ceiling should extend above the top of the fume hood and be cut around the mechanical connections to make certain correct room pressure control of the HVAC system.

## FUME HOODS FUME HOOD ACCESSORIES

### Observation™ Single-Faced Furring Panels

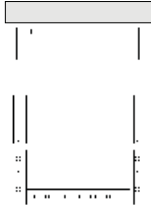

- Fume hood furring panels are used to close off the area between the top of a fume hood and the ceiling.
- Based on 108" ceiling height.
- Furring panel is 12" high, 27-3/8" deep.

Width	4 Sided Furring Panel	Front Only	Front & Both Side Panels
36"	FPB9236	FPB9336	FPB9436
48"	FPB9248	FPB9348	FPB9448
60"	FPB9260	FPB9360	FPB9460
72"	FPB9272	FPB9372	FPB9472
96"	FPB9296	FPB9396	FPB9496

### RFV2™ Furring Panels



- Fume hood furring panels are used to close off the area between the top of a fume hood and the ceiling.
- Furring panels may be ordered with only one side panel or both.
- Based on 108" ceiling height.
- Furring panel is 19" high, 36" deep.

Width	Front & Side Panels			Front Only
	Both	Left	Right	
48"	F2V9048	F2L9048	F2R9048	F2F9048
60"	F2V9060	F2L9060	F2R9060	F2F9060
72"	F2V9072	F2L9072	F2R9072	F2F9072
96"	F2V9096	F2L9096	F2R9096	F2F9096

### RFV2™ Furring Panels with Hinged Access



- Fume hood furring panels are used to close off the area between the top of a fume hood and the ceiling.
- Furring panels may be ordered with only one side panel or both.
- Based on 108" ceiling height.
- Furring panel is 19" high, 36" deep. Hinged access panel is 12" high.

Width	Front & Side Panels			Front Only
	Both	Left	Right	
48"	F2V9248	F2L9248	F2R9248	F2F9248
60"	F2V9260	F2L9260	F2R9260	F2F9260
72"	F2V9272	F2L9272	F2R9272	F2F9272
96"	F2V9296	F2L9296	F2R9296	F2F9296

### Furring Panel with Front Snap Off Panel



- Fume hood furring panels are used to close off the area between the top of a fume hood and the ceiling.
- Based on 108" ceiling height.
- Snap off front access panel with no exposed fasteners, mounts to top of the hood.
- Three sided furring panel includes rear wall mounting angles.



\*Furring panels shown on Pro Series

Width	3 Sided Furring Panel	
	Pro Series	RFV2 & SafeGuard
36"	FPM9336	-
48"	FPM9348	FPC9348
60"	FPM9360	FPC9360
72"	FPM9372	FPC9372
96"	FPM9396	FPC9396

Width	Double Sided Furring Panel		
	Pro Series	Demostration	RFV2 & SafeGuard
36"	FPG9436	FPH9436	-
48"	FPG9448	FPH9448	FPT9448
60"	FPG9460	FPH9460	FPT9460
72"	FPG9472	FPH9472	FPT9472
96"	FPG9496	FPH9496	FPT9496

## LABORATORY

## FURNITURE

**Recommendation For Installation:** When ceilings are suspended, it is recommended that the furring panel assembly extend to the underside of the ceiling. The floating ceiling should extend above the top of the fume hood and be cut around the mechanical connections to make certain correct room pressure control of the HVAC system.

*FUME HOODS*  
*FUME HOOD ACCESSORIES*

**LABORATORY FURNITURE**

**Recommendation For Installation:** When ceilings are suspended, it is recommended that the furring panel assembly extend to the underside of the ceiling. The floating ceiling should extend above the top of the fume hood and be cut around the mechanical connections to make certain correct room pressure control of the HVAC system.

**Observation2™ Single-Faced Furring Panels**



Width	4 Sided Furring Panel	Front Only	Front & Both Side Panels
48"	FNV9248	FNV9348	FNV9448
60"	FNV9260	FNV9360	FNV9460
72"	FNV9272	FNV9372	FNV9472

- Fume hood furring panels are used to close off the area between the top of a fume hood and the ceiling.
- Based on 108" ceiling height.
- Furring panel is 12" high, 28" deep.

**Observation2™ Double-Faced Furring Panels**



Width	4 Sided Furring Panel	Front & Back Only
48"	FNV9048	FNV9148
60"	FNV9060	FNV9160
72"	FNV9072	FNV9172

- Fume hood furring panels are used to close off the area between the top of a fume hood and the ceiling.
- Based on 108" ceiling height.
- Furring panel is 12" high, 56" deep.

*FUME HOODS*  
*FUME HOOD ACCESSORIES*

**Finished Back Panels**

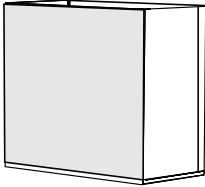

- Finished back panels are used to close of the back of a fume hood when the back is in plain view (ex: island applications).
- Actual panel height is 53", 65" or 90".
- Finished Back Panels are held in place with screws.

Finished Back Panels For Fume Hoods				
Width	Fume Hood Height 54-1/4"	Fume Hood Height 66-1/4"	Fume Hood Height 90"	Optima Fume Hood
36"	FBP3036	FBP4036	FBP5036	-
48"	FBP3048	FBP4048	FBP5048	FBP7048
60"	FBP3060	FBP4060	FBP5060	FBP7060
72"	FBP3072	FBP4072	FBP5072	FBP7072
96"	FBP3096	FBP4096	FBP5096	-
1000mm	FBP300B	FBP400B	FBP500B	-
1513mm	FBP300C	FBP400C	FBP500C	-
2000mm	FBP300D	FBP400D	FBP500D	-

**Structural Finished Back Panels**

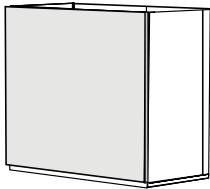

- Finished back panels are used to close of the back of a fume hood when the back is in plain view (ex: island applications).
- Structural Finished Back Panel adds 1" to the overall depth of the fume hood and is supplied in two pieces.
- Mounting screws are concealed under plastic plugs.
- Actual panel height is 53", 65" or 90".

Structural Finished Back Panels For Fume Hoods				
Width	Fume Hood Height 54-1/4"	Fume Hood Height 66-1/4"	Fume Hood Height 90"	Optima Fume Hood
36"	EBP3036	EBP4036	EBP5036	-
48"	EBP3048	EBP4048	EBP5048	EBP7048
60"	EBP3060	EBP4060	EBP5060	EBP7060
72"	EBP3072	EBP4072	EBP5072	EBP7072
96"	EBP3096	EBP4096	EBP5096	-
1000mm	EBP300B	EBP400B	EBP500B	-
1513mm	EBP300C	EBP400C	EBP500C	-
2000mm	EBP300D	EBP400D	EBP500D	-

**End Cover Panel Scribes**

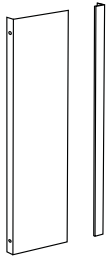

- The End Cover Panel Scribes are used to close spaces between the back of a fume hood and a wall. The Scribe feature allows for easy width adjustment in the field.
- 54-1/4" high

Width	Item Number
1"	ECS6001
2"	ECS6002
3"	ECS6003
4"	ECS6004
5"	ECS6005
6"	ECS6006
7"	ECS6007

**End Cover Channels**

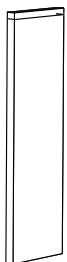

- The End Cover Channel performs the same task as the End Cover Panel Scribe but is of a fixed width.
- 54-1/4" high

Width	Item Number
1"	ECC6001
2"	ECC6002
3"	ECC6003
4"	ECC6004
5"	ECC6005
6"	ECC6006
7"	ECC6007

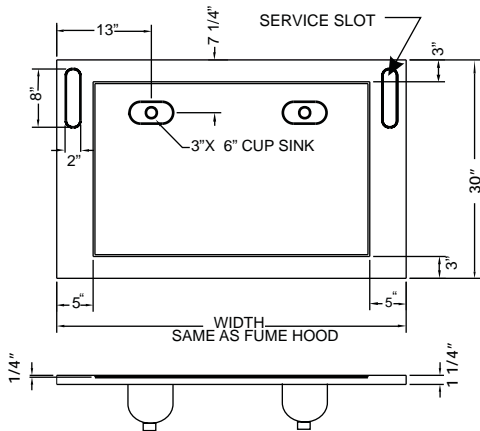
**FUME HOODS**  
**FUME HOOD ACCESSORIES**
**Pro Series Work Surfaces**

<b>Black Epoxy Cup Sink Cover</b>
EFC0000

<b>Black Epoxy Cup Sink 3" X 6" OVAL</b>
EFC1000

- Black epoxy cup sink cover fits over cupsink (not shown).

Fume Hood 316-4 Stainless Steel Work Surfaces				
Width	Plain	Cup Sink		
		Left	Twin	Right
36"	FTP0136	FTL0136	FTT0136	FTR0136
48"	FTP0148	FTL0148	FTT0148	FTR0148
60"	FTP0160	FTL0160	FTT0160	FTR0160
72"	FTP0172	FTL0172	FTT0172	FTR0172
96"	FTP0196	FTL0196	FTT0196	FTR0196
1000mm	FTP010B	FTL010B	FTT010B	FTR010B
1513mm	FTP010C	FTL010C	FTT010C	FTR010C
2000mm	FTP010D	FTL010D	FTT010D	FTR010D

Fume Hood Black Epoxy Work Surfaces				
Width	Plain	Cup Sink		
		Left	Twin	Right
36"	EFP3036	EFL3036	EFT3036	EFR3036
48"	EFP3048	EFL3048	EFT3048	EFR3048
60"	EFP3060	EFL3060	EFT3060	EFR3060
72"	EFP3072	EFL3072	EFT3072	EFR3072
96"	EFP3096	EFL3096	EFT3096	EFR3096
1000mm	EFP300B	EFL300B	EFT300B	EFR300B
1513mm	EFP300C	EFL300C	EFT300C	EFR300C
2000mm	EFP300D	EFL300D	EFT300D	EFR300D

- Cup sinks are located for 18" deep fume hood base cabinets.
- Work surfaces suitable for Pro Series fume hoods only.

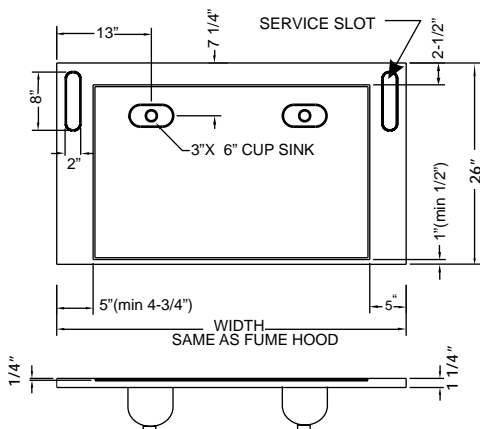
**RFV2™ Work Surfaces**

<b>Black Epoxy Cup Sink Cover</b>
EFC0000

<b>Black Epoxy Cup Sink 3" X 6" OVAL</b>
EFC1000

- Black epoxy cup sink cover fits over cupsink (not shown).

Fume Hood 316-4 Stainless Steel Work Surfaces				
Width	Plain	Cup Sink		
		Left	Twin	Right
36"	RTP0236	RTL0236	RTT0236	RTR0236
48"	RTP0248	RTL0248	RTT0248	RTR0248
60"	RTP0260	RTL0260	RTT0260	RTR0260
72"	RTP0272	RTL0272	RTT0272	RTR0272
96"	RTP0296	RTL0296	RTT0296	RTR0296
1000mm	RTP010B	RTL020B	RTT020B	RTR020B
1513mm	RTP010C	RTL020C	RTT020C	RTR020C
2000mm	RTP010D	RTL020D	RTT020D	RTR020D

Fume Hood Black Epoxy Work Surfaces				
Width	Plain	Cup Sink		
		Left	Twin	Right
36"	RFP2636	RFL2636	RFT2636	RFR2636
48"	RFP2648	RFL2648	RFT2648	RFR2648
60"	RFP2660	RFL2660	RFT2660	RFR2660
72"	RFP2672	RFL2672	RFT2672	RFR2672
96"	RFP2696	RFL2696	RFT2696	RFR2696
1000mm	RFP260B	RFL260B	RFT260B	RFR260B
1513mm	RFP260C	RFL260C	RFT260C	RFR260C
2000mm	RFP260D	RFL260D	RFT260D	RFR260D

- Cup sinks are located for 18" deep fume hood base cabinets.
- Work surfaces suitable for RFV2™ fume hoods only.

*FUME HOODS*  
*FUME HOOD ACCESSORIES*

**SafeGuard™ Work Surfaces For 32-5/8" Deep Hood**

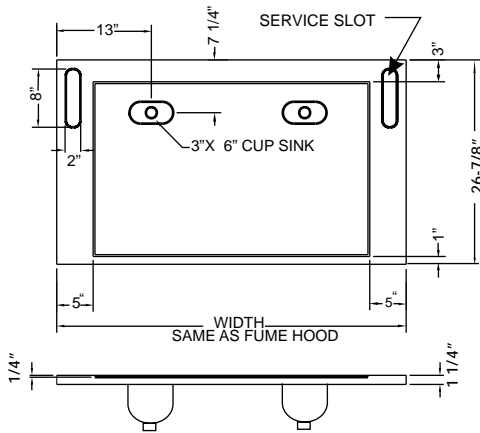

**Black Epoxy Cup Sink Cover**  
EFC0000

**Black Epoxy Cup Sink 3" X 6" OVAL**  
EFC1000

- Black epoxy cup sink cover fits over cupsink (not shown).

Fume Hood 316-4 Stainless Steel Work Surfaces 26-7/8" D				
Width	Plain	Cup Sink		
		Left	Twin	Right
36"	STP0336	STL0336	STT0336	STR0336
48"	STP0348	STL0348	STT0348	STR0348
60"	STP0360	STL0360	STT0360	STR0360
72"	STP0372	STL0372	STT0372	STR0372
96"	STP0396	STL0396	STT0396	STR0396
1000mm	STP030B	STL030B	STT030B	STR030B
1513mm	STP030C	STL030C	STT030C	STR030C
2000mm	STP030D	STL030D	STT030D	STR030D

Fume Hood Black Epoxy Work Surfaces 26-7/8" D				
Width	Plain	Cup Sink		
		Left	Twin	Right
36"	SFP2736	SFL2736	SFT2736	SFR2736
48"	SFP2748	SFL2748	SFT2748	SFR2748
60"	SFP2760	SFL2760	SFT2760	SFR2760
72"	SFP2772	SFL2772	SFT2772	SFR2772
96"	SFP2796	SFL2796	SFT2796	SFR2796
1000mm	SFP270B	SFL270B	SFT270B	SFR270B
1513mm	SFP270C	SFL270C	SFT270C	SFR270C
2000mm	SFP270D	SFL270D	SFT270D	SFR270D

- Cup sinks are located for 18" deep fume hood base cabinets.
- Work surfaces suitable for SafeGuard™ fume hoods only.

**SafeGuard™ Work Surfaces For 38-5/8" Deep Hood**

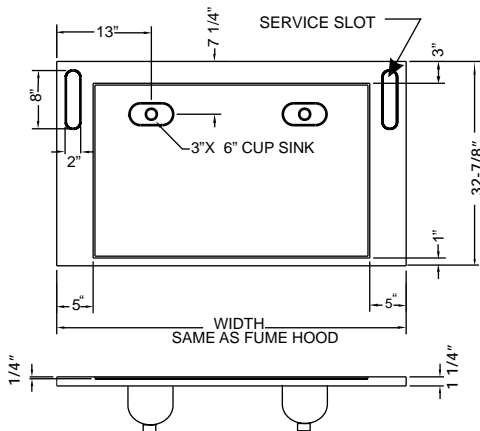

**Black Epoxy Cup Sink Cover**  
EFC0000

**Black Epoxy Cup Sink 3" X 6" OVAL**  
EFC1000

- Black epoxy cup sink cover fits over cupsink (not shown).

Fume Hood 316-4 Stainless Steel Work Surfaces 32-7/8" D				
Width	Plain	Cup Sink		
		Left	Twin	Right
36"	STP0436	STL0436	STT0436	STR0436
48"	STP0448	STL0448	STT0448	STR0448
60"	STP0460	STL0460	STT0460	STR0460
72"	STP0472	STL0472	STT0472	STR0472
96"	STP0496	STL0496	STT0496	STR0496
1000mm	STP040B	STL040B	STT040B	STR040B
1513mm	STP040C	STL040C	STT040C	STR040C
2000mm	STP040D	STL040D	STT040D	STR040D

Fume Hood Black Epoxy Work Surfaces 32-7/8" D				
Width	Plain	Cup Sink		
		Left	Twin	Right
36"	SFP3336	SFL3336	SFT3336	SFR3336
48"	SFP3348	SFL3348	SFT3348	SFR3348
60"	SFP3360	SFL3360	SFT3360	SFR3360
72"	SFP3372	SFL3372	SFT3372	SFR3372
96"	SFP3396	SFL3396	SFT3396	SFR3396
1000mm	SFP330B	SFL330B	SFT330B	SFR330B
1513mm	SFP330C	SFL330C	SFT330C	SFR330C
2000mm	SFP330D	SFL330D	SFT330D	SFR330D

- Cup sinks are located for 18" deep fume hood base cabinets.
- Work surfaces suitable for SafeGuard™ fume hoods only.



*FUME HOODS*  
*FUME HOOD ACCESSORIES*

**Observation™ Work Surfaces**

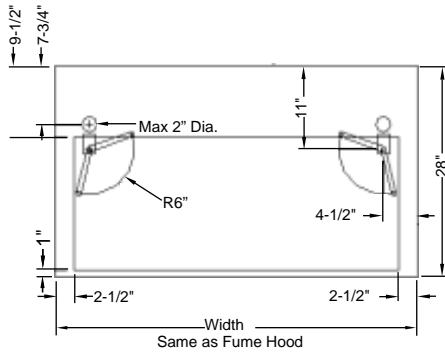

Fume Hood 316-4 Stainless Steel Work Surfaces	
Width	Plain
48"	OTP0548
60"	OTP0560
72"	OTP0572

Fume Hood Black Epoxy Work Surfaces	
Width	Plain
48"	OFP2848
60"	OFP2860
72"	OFP2872

- Work surfaces suitable for Observation™ fume hoods only.
- Double faced island fume hoods require two work surfaces.
- Single faced fume hoods require one work surface.

**Polyolefin Vent Sets**

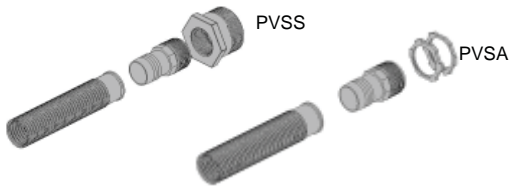

Description	Item Number
Polyolefin Vent Set for Acid Cabinet With FRP Liner	PVSA
Polyolefin Vent Set for Acid Cabinet With Molded Liner	PVSS

- For venting acid storage cabinets (Not recommended for flammable storage cabinets).
- Flexible corrugated vent tube is 8' feet long and comes with fitting to attach to rear of cabinet.

**Fume Hood Fixture Hole Covers**



Stainless Steel Interior/Exterior Plug



Black Exterior Plug



White Interior Plug

Item Number	Front Load Exterior Application
HCBFE00	1-1/4" Dia Black Plug for Plumbing Holes
HCPFE00	1/4" Dia Painted Stainless Plug for Plumbing Holes
HCSFE00	1/4" Dia Stainless Plug for Plumbing Holes

- These plugs are used to cover exterior fixture plumbing holes in various materials on a fume hood plumbed with front load fixtures.

Item Number	Rod Type Exterior Application
HCBRE00	5/8" Dia Black Plug for Plumbing Holes
HCPRE00	5/8" Dia Painted Stainless Plug for Plumbing Holes
HCSRE00	5/8" Dia Stainless Plug for Plumbing Holes

- These plugs are used to cover exterior fixture plumbing holes in various materials on a fume hood plumbed with rod type fixtures.

Item Number	Interior Application
HCWN100	3/4" Dia White Plug for Plumbing Holes
HCA100	1" Dia White Plug for Alarm Holes
HCSN100	3/4" Dia Stainless Plug for Plumbing Holes

- These plugs are used to cover interior fixture plumbing and alarm holes in various materials on any fume hood.



*FUME HOODS*  
*FUME HOOD ACCESSORIES*

**Fume Hood Table**



Width	Left Hand Cup Sink Location	Right Hand Cup Sink Location
	22" Deep	22" Deep
48"	HTL2148	HTR2148
60"	HTL2160	HTR2160
72"	HTL2172	HTR2172

- Fully welded "U" frame table with plumbing enclosure, modesty panel and end filler panels.
- For use at wall conditions only.
- Height adjustable from 28-3/4" to 34-3/4" in 1" increments.
- 2" x 2" tube construction.
- Table fits standard depth (32-5/8" deep) fume hoods.
- Snap off access panel on inside of plumbing enclosure.
- Maximum load rating is 1000lbs.

*FUME HOODS*  
*FUME HOOD OPTIONS*

**Options Index**

<b>Option #:</b>	<b>Description:</b>
52	Entire 316 Stainless Steel Construction
53	Entire Satin Coat Construction (Sigma Barrier™)
A1	Alarm - add detail to data sheet - specify make and model
A2	Alarm Cutout Only - add detail to data sheet
A3	Magnahelic Gauge - add detail to data sheet
A4	Minihelic Gauge - add detail to data sheet
A5	VAV Control Installed - (customer supplied) - add detail to data sheet
A6	VAV Control - electrical box only - add detail to data sheet
B2	Baffle - remote control adjustable top, fixed sides and center
E1	Special Wiring/Voltage - add detail to data sheet
E2	Not Wired - fluorescent light mounted only
E3	Explosion Proof Wiring - add detail to data sheet
E5	Motor/Blower Switch
E6	Fluorescent Canopy Light (wired to junction box)
E7	T5 Fluorescent Light
ED	Extra Deep SafeGuard™ Fume Hood at 38-5/8" Deep
G1	Finished Back Panel (on fume hood)
G2	Fire Extinguisher
G3	Partially Crated (for full crating please contact your Sales Co-ordinator)
G4	Fume Hood Exterior - 316 stainless steel
G5	Fume Hood Exterior - 304 stainless steel
GB	Glass Back Panel - Replaces solid back panel with glass (for single-faced Observation™ fume hood).
H1	Solid End Panels on Left - Replaces glass end panels on left with solid end panels when hood is located against a wall (for Island Observation™ fume hood).
H2	Solid End Panels on Right - Replaces glass end panels on right with solid end panels when hood is located against a wall (for Island Observation™ fume hood).
H3	Solid End Panel on Left - Replaces glass end panel on left with solid end panel when hood is located against a wall (for single-faced Observation™ fume hood).
H4	Solid End Panel on Right - Replaces glass end panel on right with solid end panel when hood is located against a wall (for single-faced Observation™ fume hood).
KD	Knock Down with Photo/Instructions
LA	Bilingual Label (English/French)
LV	Low Volume
P1	Factory Plumbing Mount only - add detail to data sheet
P2	Factory Pre-Plumbed Up - add detail to data sheet
P3	Factory Pre-Plumbed Down - add detail to data sheet
P4	Customer Installed Plumbing - add detail to data sheet
P5	Cup Sink - RH side rear (Stainless Steel seamless corner hood only)
P6	Cup Sink - LH side rear (Stainless Steel seamless corner hoods only)
PN	No Factory Plumbing (fume hood equipped with standard plugged fixture holes)
S1	No Upper By-Pass
S2	Restricted By-Pass Adjustable Blank Off Plate
S3	Plastic Sash Stop @ 18"
S4	Plastic Sash Stop @ specify
S5	Sash Box Enclosure
S6	Baffle Screen Stainless Steel
S7	Airfoil With No Electrical Cut Outs -add detail to data sheet
S8	Sash Interlock
S9	Sash Key Lock
SC	Self Lowering Sash Mechanism - automatically lowers the sash to the chosen working height (suitable for chain drive fume hoods)
SM	Automatic Sash Operator - only available on chain drive vertical rising sash hoods
W1	Window (in one side wall only, as the other side is required for sash counter weights)

*MOBILITY  
ADAPTABLE LABORATORY FURNITURE SOLUTIONS*

**The Solution to Change...**

Laboratory technology changes today at an ever-increasing rate. Today's challenge is to provide the longest possible life to your lab. Mott's flexible furniture systems successfully meet this challenge by delivering ultimate adaptability and adjustability with exceptional architectural style.

Mott's mobile-friendly components provide future adaptability because workstations and instruments can be positioned on movable carts and tables rather than permanent benches. Mobile units can be configured to provide the same storage as fixed casework and yet remain flexible to accommodate a variety of users, equipment, and process changes.

Overhead service carriers provide overhead access of plumbed and wired services while providing maximum flexibility by eliminating obtrusive services originating from the floor. When mobile carts and tables are used, instruments can be easily installed and connected to the service supply as needed and simply moved out of the way when finished or needs change.

**For additional information and help in planning contact Mott Manufacturing.**

*MOBILITY  
ADAPTABLE LABORATORY FURNITURE SOLUTIONS*

**Sigma Carts™**

Sigma Carts™ are ideal solutions to workstations that require high levels of durability, mobility, adjustability, and adaptability all with a contemporary design. These carts can be easily integrated either into existing work spaces or to locate them as independent self supporting work stations, which makes them ideal for sharing instrumentation, tools, or processes within the same laboratory area. Individual carts can be joined together and connected to overhead service carriers to create larger modular work units.

Full Height and Low Sigma Carts™ are offered in two different depths and are available in various widths. Sigma Carts™ can be configured with a broad range of accessories including adjustable work surfaces, suspended upper and lower cabinets, adjustable shelving, electrical raceways, task lighting, peg boards, tack boards, and marker boards.

Convenient height adjustment allows custom adaptation to specific operator and/or process requirements.

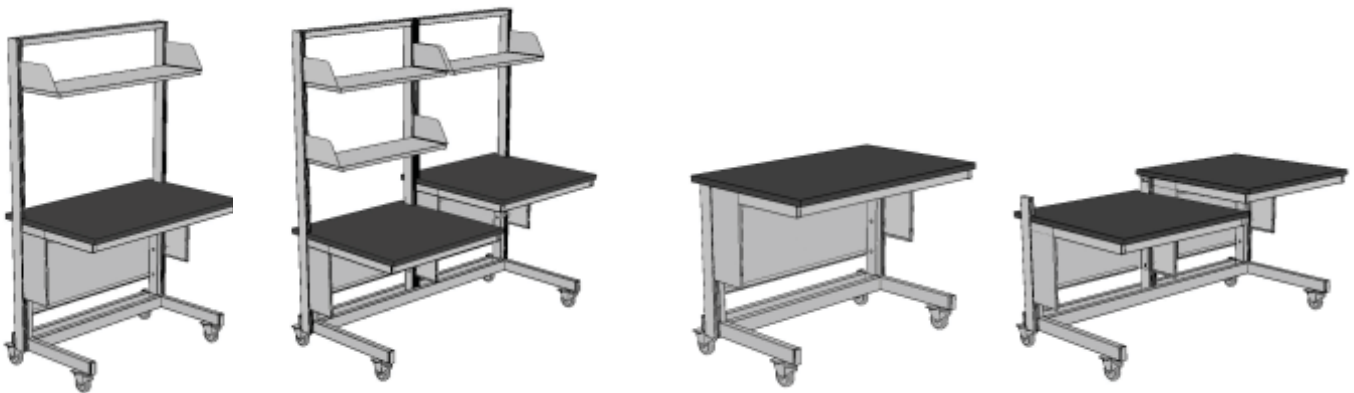

**Load Ratings**

Sigma Cart™ assembly consists of cart frame and cantilevered table frame. Order suspended cabinets, wall cabinets, shelves and accessories separately.

**Load Maximums**

Maximum load ratings are live loads and include loads applied to top of work surface, including total weight of shelves and suspended cabinetry and other accessories. These capacities should be used as guidelines only. Please contact Mott Manufacturing for specific load requirements. Maximum load ratings are based on the load being evenly balanced. Individual component or assembly load ratings should not be exceeded for any surface.

**Maximum Load Ratings Per Cart**

- Single work surface 600lbs
- Split work surface 300lbs
- Total Shelving 300lbs
- Total Load Rating 900lbs

For ordering suspended cabinets and wall cabinets refer to those sections in the catalog.

*MOBILITY*  
*SIGMA CART™ - 36" HIGH*

**Low Cart Assemblies**



Low Cart Assembly is 36" high with 1" work top installed.

Width	23" Deep	29" Deep
24"	MWS2024	MWS2124
30"	MWS2030	MWS2130
36"	MWS2036	MWS2136
42"	MWS2042	MWS2142
48"	MWS2048	MWS2148
54"	MWS2054	MWS2154
60"	MWS2060	MWS2160
72"	MWS2072	MWS2172

- Low cart assembly is 36" high and comes complete with cantilevered table frame, height adjustable in 1" increments (work surface not included).
- Upper Cart assembly can be added in the future.
- Shelves can be installed below work surface (accepts standard Sigma Flex™shelves).
- Hanging rails are included on table frame to suspend lower cabinets.
- Total lock steel swivel casters.
- Overall depth of cart is 30" deep with 23"deep table frame.
- Overall depth of cart is 36" deep with 29"deep table frame.
- Shipped assembled.

**Typical Sigma Cart™ work top for 23" and 29" deep units.**

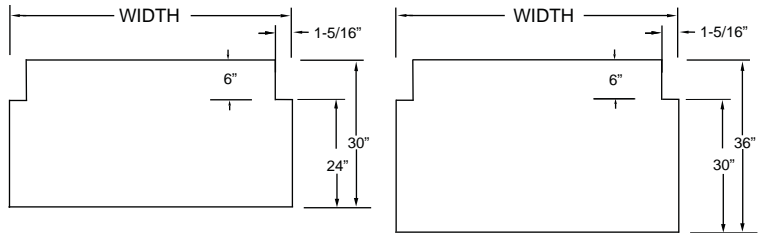

**Low Double Cart Assemblies**



Low Double Cart Assembly is 36" high with 1" work top installed.

Width	23" Deep	29" Deep
60"	MWD2060	MWD2160
72"	MWD2072	MWD2172

- Low cart double assembly is 36" high and comes complete with cantilevered table frame, height adjustable in 1" increments (work surface not included).
- Assembly is 60" or 72" wide with middle upright being centered.
- Upper Cart assembly can be added in the future.
- Shelves can be installed below work surface (accepts standard Sigma Flex™shelves).
- Hanging rails are included on table frame to suspend lower cabinets.
- Total lock steel swivel casters.
- Overall depth of cart is 30" deep with 23"deep table frame.
- Overall depth of cart is 36" deep with 29"deep table frame.
- Shipped assembled.

**Typical Sigma Cart™ work top for 23" and 29" deep units.**

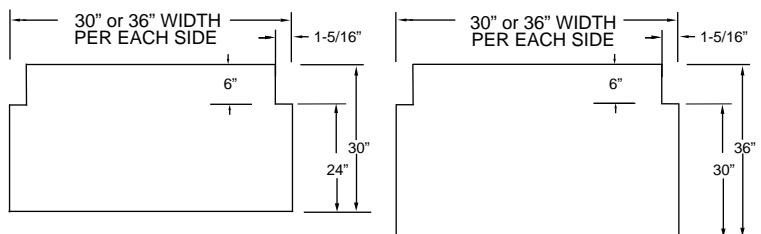

*MOBILITY*  
*SIGMA CART™ - 78" HIGH*

**Full Height Cart Assemblies**



Width	23" Deep	29" Deep
24"	MWS1024	MWS1124
30"	MWS1030	MWS1130
36"	MWS1036	MWS1136
42"	MWS1042	MWS1142
48"	MWS1048	MWS1148
54"	MWS1054	MWS1154
60"	MWS1060	MWS1160
72"	MWS1072	MWS1172

- One piece full height cart assembly is 78" high and comes complete with cantilevered table frame, height adjustable in 1" increments (work surface is not included).
- Shelves can be installed above and below work surface (accepts standard Sigma Flex™shelves).
- Hanging rails are included on table frame to suspend lower cabinets.
- Total lock steel swivel casters.
- Overall depth of cart is 30" deep with 23"deep table frame.
- Overall depth of cart is 36" deep with 29"deep table frame.
- Shipped assembled.

**Typical Sigma Cart™ work top for 23" and 29" deep units.**

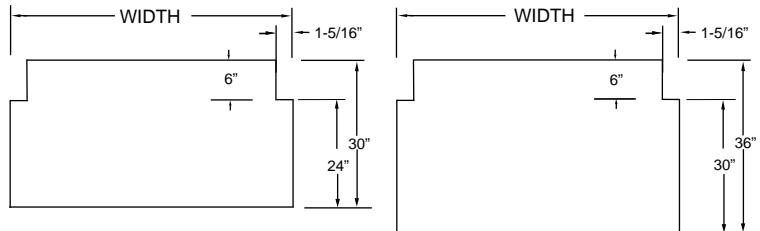

**Full Height Double Cart Assemblies**



Width	23" Deep	29" Deep
60"	MWD1060	MWD1160
72"	MWD1072	MWD1172

- One piece full height cart double assembly is 78" high and comes complete with cantilevered table frame, height adjustable in 1" increments (work surface is not included).
- Shelves can be installed above and below work surface (accepts standard Sigma Flex™shelves).
- Hanging rails are included on table frame to suspend lower cabinets.
- Total lock steel swivel casters.
- Overall depth of cart is 30" deep with 23"deep table frame.
- Overall depth of cart is 36" deep with 29"deep table frame.
- Shipped assembled.

**Typical Sigma Cart™ work top for 23" and 29" deep units.**

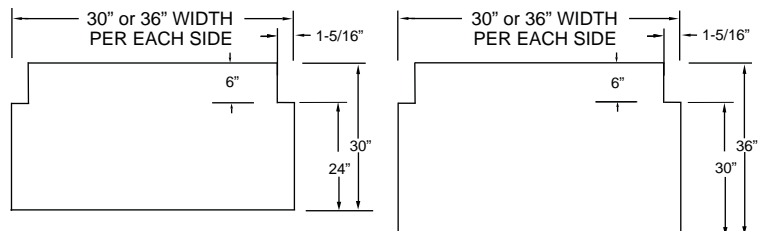

*MOBILITY*  
*SIGMA CART™ COMPONENT ACCESSORIES*

**Upper Cart Assemblies - 43-1/4" High**



Width	Item Number
24"	MWS3024
30"	MWS3030
36"	MWS3036
42"	MWS3042
48"	MWS3048
54"	MWS3054
60"	MWS3060
72"	MWS3072

- One piece upper cart assembly is 43-1/4" high.
- Mounts on top of low cart to create a full height assembly.
- Specify two 30" or 36" wide uppers for 60" or 72" low double cart assembly.
- Shelves can be installed (accepts standard Sigma Flex™shelves).
- Shipped assembled.
- Hardware included.

**Wall Cabinet Hanger Rails**

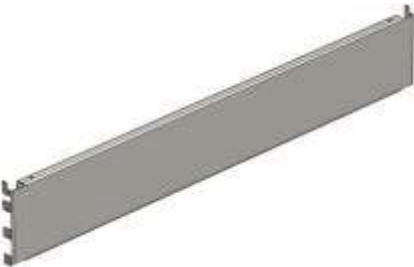

Width	Item Number
24"	FWR0024
30"	FWR0030
36"	FWR0036
42"	FWR0042
48"	FWR0048
54"	FWR0054
60"	FWR0060
66"	FWR0066
72"	FWR0072

- A Wall Cabinet Hanger Rail is required to hang above-counter storage cabinets on to Sigma Flex™ and Sigma Cart™ products.
- Order rails to match width of support structure frame.
- See wall cabinet section to order cabinets.
- Wall cabinets must be ordered with option code FR to suspend from Sigma Flex™and Sigma Cart™ products.

**Sigma Cart™ Cover Panels**

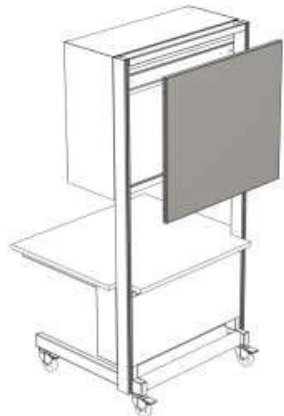

Cart Width	Wall Cabinet Height				
	16-1/2" High	24" High	30" High	36" High	48" High
24"	-	FFB2424	FFB2430	FFB2436	FFB2448
30"	FFB3016	FFB3024	FFB3030	FFB3036	FFB3048
36"	FFB3616	FFB3624	FFB3630	FFB3636	FFB3648
42"	-	FFB4224	FFB4230	FFB4236	FFB4248
48"	FFB4816	FFB4824	FFB4830	FFB4836	FFB4848
54"	-	FFB5424	FFB5430	FFB5436	FFB5448
60"	-	FFB6024	FFB6030	FFB6036	FFB6048
72"	-	FFB7224	FFB7230	FFB7236	FFB7248

- Finished back panel for wall cabinets to hang on full height cart assembly.
- 16-1/2" high Sigma Cart™ Cover Panel suits a Flipper Door wall cabinet.
- "S" clips provided by Mott.
- See wall cabinet section to order cabinets.
- Wall cabinets must be ordered with option code "FR" to suspend from cart.
- Cannot attach peg boards or marker boards to Sigma™ Cover Panels.

**Stationary Feet**



Option Code
SF

- Add Option Code SF to order stationary feet with levelers to Sigma Cart™ assembly.



*MOBILITY*  
*SIGMA CART™ COMPONENT ACCESSORIES*

**Supplementary Adjustable Legs**



**Option Code**

AL

- Add Option Code AL to order Supplementary Adjustable Legs to Sigma Cart™ assembly (Supplementary Legs are NOT to be used with Double Cart assemblies).
- Pair of hinged Supplementary Adjustable Legs are used to increase the load bearing capacity of the work surface from 600lbs to 1000lbs.
- Ships assembled on Sigma Carts™.

**Back-to-Back Fastener**

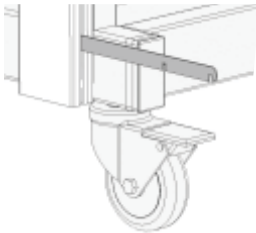

**Item Number**

BBB0000

- Stainless steel bracket suitable for any Sigma Cart™.
- Bracket attaches to cart uprights to stabilize two carts that are situated back-to-back.

**Side-to-Side Fastener**

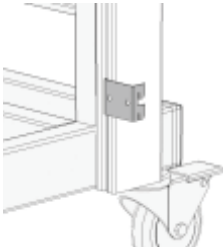

**Item Number**

SSB0000

- Powder coated steel bracket suitable for any Sigma Cart™.
- Bracket attaches to cart uprights to stabilize two carts that are situated side-to-side.
- Can be used to gang Sigma Carts™ end-to-end for a continuous run.

**Power Strip Brackets**



**Item Number**

PSB0000

- Pair of brackets to mount power strips (power strips not included).
- Allows the power strips to sit flush against the back edge of the brackets.

**Power Strip Rail with Brackets**



Width	Item Number
24"	PSR0024
30"	PSR0030
36"	PSR0036
42"	PSR0042
48"	PSR0048
54"	PSR0054
60"	PSR0060
72"	PSR0072

- Power Strip Rail with Brackets for mounting of power strips (power strips not included).

*MOBILITY*  
*SIGMA CART™ SHELVES*

**Shelves**

Sigma Cart™ is designed and manufactured to accommodate upper and below work surface shelving. Shelves are adjustable in height and available in various widths and depths.

**Outer and Top Shelves**



Steel Shelves							
Width	6" Deep	8" Deep	10" Deep	12" Deep	14" Deep	18" Deep	24" Deep
24"	FSH0624	FSH0824	FSH1024	FSH1224	FSH1424	FSH1824	FSH2424
30"	FSH0630	FSH0830	FSH1030	FSH1230	FSH1430	FSH1830	FSH2430
36"	FSH0636	FSH0836	FSH1036	FSH1236	FSH1436	FSH1836	FSH2436
42"	FSH0642	FSH0842	FSH1042	FSH1242	FSH1442	FSH1842	FSH2442
48"	FSH0648	FSH0848	FSH1048	FSH1248	FSH1448	FSH1848	FSH2448
54"	FSH0654	FSH0854	FSH1054	FSH1254	FSH1454	FSH1854	FSH2454
60"	FSH0660	FSH0860	FSH1060	FSH1260	FSH1460	FSH1860	FSH2460
66"	FSH0666	FSH0866	FSH1066	FSH1266	FSH1466	FSH1866	FSH2466
72"	FSH0672	FSH0872	FSH1072	FSH1272	FSH1472	FSH1872	FSH2472

- Shelf suitable for any Sigma Flex™ structure or Sigma Cart™.
- Attach to shelf brackets with screws (screws not included).
- Nominal width.
- To order Under Mount Shelf Task Light refer to steel Miscellaneous Section, page R9.



Wood Shelves							
Width	6" Deep	8" Deep	10" Deep	12" Deep	14" Deep	18" Deep	24" Deep
24"	FSH0624W	FSH0824W	FSH1024W	FSH1224W	FSH1424W	FSH1824W	FSH2424W
30"	FSH0630W	FSH0830W	FSH1030W	FSH1230W	FSH1430W	FSH1830W	FSH2430W
36"	FSH0636W	FSH0836W	FSH1036W	FSH1236W	FSH1436W	FSH1836W	FSH2436W
42"	FSH0642W	FSH0842W	FSH1042W	FSH1242W	FSH1442W	FSH1842W	FSH2442W
48"	FSH0648W	FSH0848W	FSH1048W	FSH1248W	FSH1448W	FSH1848W	FSH2448W
54"	FSH0654W	FSH0854W	FSH1054W	FSH1254W	FSH1454W	FSH1854W	FSH2454W
60"	FSH0660W	FSH0860W	FSH1060W	FSH1260W	FSH1460W	FSH1860W	FSH2460W

- Shelf suitable for any Sigma Flex™ structure or Sigma Cart™.
- Attach to shelf brackets with screws (screws not included).
- Nominal width.
- To order Under Mount Shelf Task Light refer to steel Miscellaneous Section, page R9.

**Wood Shelving Options**



Height	Back Lip	Front Lip	Back and Front Lip
1"	ARW1	AFW1	ABW1
2"	ARW2	AFW2	ABW2
3"	ARW3	AFW3	ABW3
4"	ARW4	AFW4	ABW4

- Height of the lip is measured from the top of the shelf to the top of the lip. Lip is 3/4" thick.
- Shelves are 1" thick.

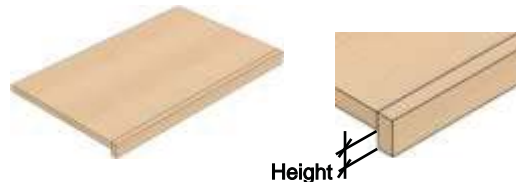

Height	Front Valance
1"	FV1
2"	FV2
3"	FV3
4"	FV4

- Height of the valance is measured from the bottom of the shelf to the bottom of the valance. Valance is 3/4" thick.
- Shelves are 1" thick.

*MOBILITY*  
*SIGMA CART™ SHELVES*

**Outer Shelf Brackets**



Depth	Item Number
6"	FSB0006
8"	FSB0008
10"	FSB0010
12"	FSB0012
14"	FSB0014
18"	FSB0018
24"	FSB0024

- Pair of steel end brackets designed to fit Adjustable Outer Shelf and can be used for shelves of different materials.
- Adjustable in 1" increments.
- Brackets only compatible with Sigma Flex™ structures or Sigma Cart™.

**15° Angled Outer Shelf Brackets**



Depth	Item Number
10"	ASB0010
12"	ASB0012
14"	ASB0014
16"	ASB0016
18"	ASB0018

- Pair of steel end brackets designed to fit Outer and Top Shelves and can be used for shelves of different materials.
- Shelf brackets designed at a fixed 15° angle.
- Adjustable in 1" increments.
- Brackets only compatible with Sigma Flex™ structures or Sigma Cart™.

**Optional Steel Shelf Angles**



(Shelf with rear angle shown.)

- Shelf with rear steel angle is suitable for any Sigma Flex™ structure or Sigma Cart™.
- Attach to shelf brackets with screws (screws not included).
- Use option codes below to add angles to shelves:
  - AR (Rear Shelf Angle welded to shelf)
  - AF (Front Shelf Angle welded to shelf)
  - AB (Rear and Front Shelf Angle welded to shelf)

*MOBILITY*  
*SIGMA CART™ SHELVES*

**Radius Top Shelf Brackets**



Depth	Item Number
6"	FIB3006
8"	FIB3008
10"	FIB3010
12"	FIB3012
14"	FIB3014
18"	FIB3018
24"	FIB3024

- Pair of steel top end brackets designed to fit Adjustable Outer Shelf and can be used for shelves of different materials.
- Adjustable in 1" increments.
- Brackets only compatible with Sigma Flex™ structures or Sigma Cart™.

**Radius Outer Shelf Brackets**



Depth	Item Number
6"	FSB3006
8"	FSB3008
10"	FSB3010
12"	FSB3012
14"	FSB3014
18"	FSB3018
24"	FSB3024

- Pair of steel end brackets designed to fit Adjustable Outer Shelf and can be used for shelves of different materials.
- Adjustable in 1" increments.
- Brackets only compatible with Sigma Flex™ structures or Sigma Cart™.

**Tapered Top Shelf Brackets**



Depth	Item Number
6"	FIB4006
8"	FIB4008
10"	FIB4010
12"	FIB4012
14"	FIB4014
18"	FIB4018
24"	FIB4024

- Pair of steel top end brackets designed to fit Adjustable Outer Shelf and can be used for shelves of different materials.
- Adjustable in 1" increments.
- Brackets only compatible with Sigma Flex™ structures or Sigma Cart™.

**Tapered Outer Shelf Brackets**

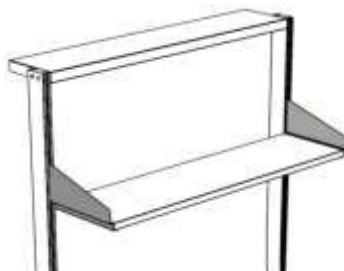

Depth	Item Number
6"	FSB4006
8"	FSB4008
10"	FSB4010
12"	FSB4012
14"	FSB4014
18"	FSB4018
24"	FSB4024

- Pair of steel end brackets designed to fit Adjustable Outer Shelf and can be used for shelves of different materials.
- Adjustable in 1" increments.
- Brackets only compatible with Sigma Flex™ structures or Sigma Cart™.

*MOBILITY  
TABLES*

**Mobile Tables**

Mobile tables are ideal work surface solutions where overhead storage or service carriers already exist, or when work surface mobility is a critical requirement. Mobile tables manufactured of powder coated or stainless steel can be configured to include lower suspended cabinets and shelving. Ideal for sitting or standing activities, these can be adjustable to be readily reconfigured for changing applications or process technologies.

Mobile tables are available in two heights and two different depths and all are offered in various widths. Table legs are manufactured with 2" x 2" 16 gauge steel tubing and lower frames are made with 1" x 2" 16 gauge steel tubing. All table legs are bolted in place for exceptional strength. Mobile tables that are manufactured to suspend hanging cabinets (option code -HU) are supplied with a lower "U" frame which supports a 600lb load.



*MOBILITY*  
*22" DEEP TABLES FOR SUSPENDING CABINETS*

**Mobile "U" Frame Tables**



Width	28-3/4" High	34-3/4" High
36"	TAC2136 Opt-87-HU	TAC1136 Opt-87-HU
42"	TAC2142 Opt-87-HU	TAC1142 Opt-87-HU
48"	TAC2148 Opt-87-HU	TAC1148 Opt-87-HU
60"	TAC2160 Opt-87-HU	TAC1160 Opt-87-HU
72"	TAC2172 Opt-87-HU	TAC1172 Opt-87-HU

- 22" deep tables will only accommodate 18" deep hanging cabinets.
- Remove option code HU to order an "H" frame table that does not need to suspend hanging cabinets.
- Tables with option code HU are manufactured with a 3" high heavy duty apron.
- Remove option code HU to order a "H" frame table that does not need to suspend hanging cabinets.
- Glass reinforced nylon total lock swivel caster with non-marking rubber wheels.
- Add option code 49 to order adjustable height legs. Legs are adjustable in 1" increments, from 28-3/4" high to 34-3/4" high.

**Six Leg Mobile "U" Frames**



Width	28-3/4" High	34-3/4" High
72"	TCC2172 Opt-87-HU	TCC1172 Opt-87-HU
84"	TCC2184 Opt-87-HU	TCC1184 Opt-87-HU
96"	TCC2196 Opt-87-HU	TCC1196 Opt-87-HU

- 22" deep tables will only accommodate 18" deep hanging cabinets.
- Remove option code HU to order an "H" frame table that does not need to suspend hanging cabinets.
- Tables with option code HU are manufactured with a 3" high heavy duty apron.
- Remove option code HU to order a "H" frame table that does not need to suspend hanging cabinets.
- Glass reinforced nylon total lock swivel caster with non-marking rubber wheels.
- Add option code 49 to order adjustable height legs. Legs are adjustable in 1" increments, from 28-3/4" high to 34-3/4" high.
- Worktop not included.

**Pencil Drawers**

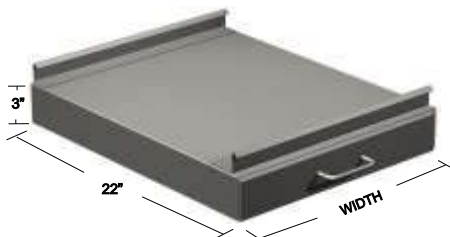

Width	Item Number
15"	PEN0015
18"	PEN0018
20"	PEN0020
24"	PEN0024
30"	PEN0030

- Suspends from table, apron or Sigma Flex™ system with hanging rails.
- Drawer supplied with full extension runners.
- Add option code HU to table or apron in order to suspend pencil drawer.



*MOBILITY*  
*28" DEEP TABLES FOR SUSPENDING CABINETS*

**Mobile "U" Frame Tables**



Width	28-3/4" High	34-3/4" High
36"	TAC2236 Opt-87-HU	TAC1236 Opt-87-HU
42"	TAC2242 Opt-87-HU	TAC1242 Opt-87-HU
48"	TAC2248 Opt-87-HU	TAC1248 Opt-87-HU
60"	TAC2260 Opt-87-HU	TAC1260 Opt-87-HU
72"	TAC2272 Opt-87-HU	TAC1272 Opt-87-HU

- 28" deep tables will accommodate 18" or 22" deep hanging cabinets.
- Remove option code HU to order an "H" frame table that does not need to suspend hanging cabinets.
- Tables with option code HU are manufactured with a 3" high heavy duty apron.
- Remove option code HU to order a "H" frame table that does not need to suspend hanging cabinets.
- Glass reinforced nylon total lock swivel caster with non-marking rubber wheels.
- Add option code 49 to order adjustable height legs. Legs are adjustable in 1" increments, from 28-3/4" high to 34-3/4" high.
- Worktop not included.

**Six Leg Mobile "U" Frames**



Width	28-3/4" High	34-3/4" High
72"	TCC2272 Opt-87-HU	TCC1272 Opt-87-HU
84"	TCC2284 Opt-87-HU	TCC1284 Opt-87-HU
96"	TCC2296 Opt-87-HU	TCC1296 Opt-87-HU

- 28" deep tables will accommodate 18" or 22" deep hanging cabinets.
- Remove option code HU to order an "H" frame table that does not need to suspend hanging cabinets.
- Tables with option code HU are manufactured with a 3" high heavy duty apron.
- Remove option code HU to order a "H" frame table that does not need to suspend hanging cabinets.
- Glass reinforced nylon total lock swivel caster with non-marking rubber wheels.
- Add option code 49 to order adjustable height legs. Legs are adjustable in 1" increments, from 28-3/4" high to 34-3/4" high.
- Worktop not included.

**Hanging CPU Holder**



Item Number
CPU1010

- Suspends from table, apron or Sigma Flex™ system with hanging rails and is supplied with full extension runners to slide out CPU unit.
- Add option code HU to table or apron in order to suspend pencil drawer.
- Inside dimension of CPU holder is 9-3/16".
- Hanging CPU Holder does not fit on a 22" deep table.



*MOBILITY  
CABINETS*

**Mobile Cabinets**

Mobile cabinets are available in numerous configurations and sizes in sitting, standing, ADA heights and are available in powder coated steel, wood, wood fronts on powder coated steel or stainless steel. Cabinets are available in either contemporary inset or architectural overlay design. Heavy duty locking 3-1/2" twin wheel casters provide a total load rating (including mobile cabinet and work top) of 500lbs. Tip resisting counter weights are provided to aid in safe operation. Resulting mobility allows the user to quickly and easily move to another workstation, as tasks change.

To order a cabinet with casters (casters replace 4" toe kick) add option code -77 to the end of any item number. For a full list of optional features go to the Steel Specs & Options or Wood Specs & Options section of our catalog.

Any sitting, standing or ADA height cabinet can be converted to a mobile cabinet by adding casters, select the two digit part number suffix from below and add this suffix after the standard part number, separated with a dash.

**OVERVIEW EXAMPLE**

To order a door/drawer mobile cabinet:

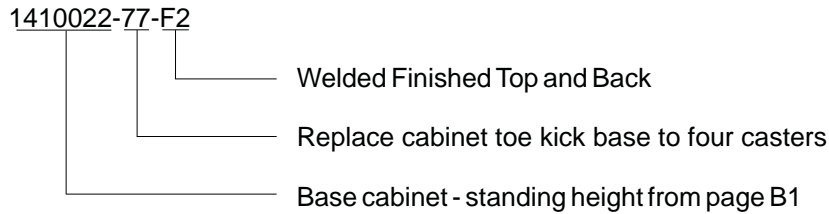

1410022

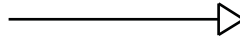

1410022-77

*MOBILITY  
OVERHEAD SERVICE CARRIERS*

**Overhead Service Carriers**

Overhead Service Carriers can be suspended or flush mounted from the ceiling of the laboratory and are available in continuous linear configurations that run the length of the room, or single units that are located on a grid pattern throughout the lab space. Overhead service carriers are designed to house services such as electrical, data, telephone, and all of the usual plumbing services, thus providing maximum flexibility by eliminating obtrusive services originating from the floor. These service carriers can also support light fixtures and snorkel exhausts. Quick disconnects enable mobile carts and tables to be plugged-in for quick and easy relocation.



*MOBILITY  
OVERHEAD SERVICE CARRIERS*

**Suspended Chameleon™**

Suspended Chameleons™ are hung from the ceiling. They can house utilities like piping, electric, data, light fixtures, and snorkel exhausts. They provide maximum flexibility as services are lifted off the floor, allowing free floor space to be configured as needed. They are height adjustable, available in various widths and come with the option of lighting.

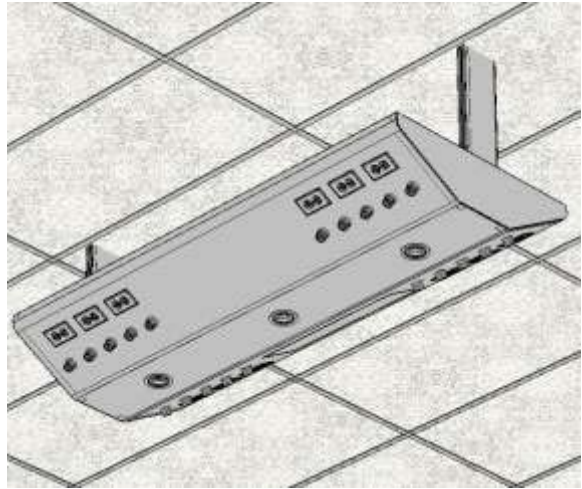

**Bottom Views**

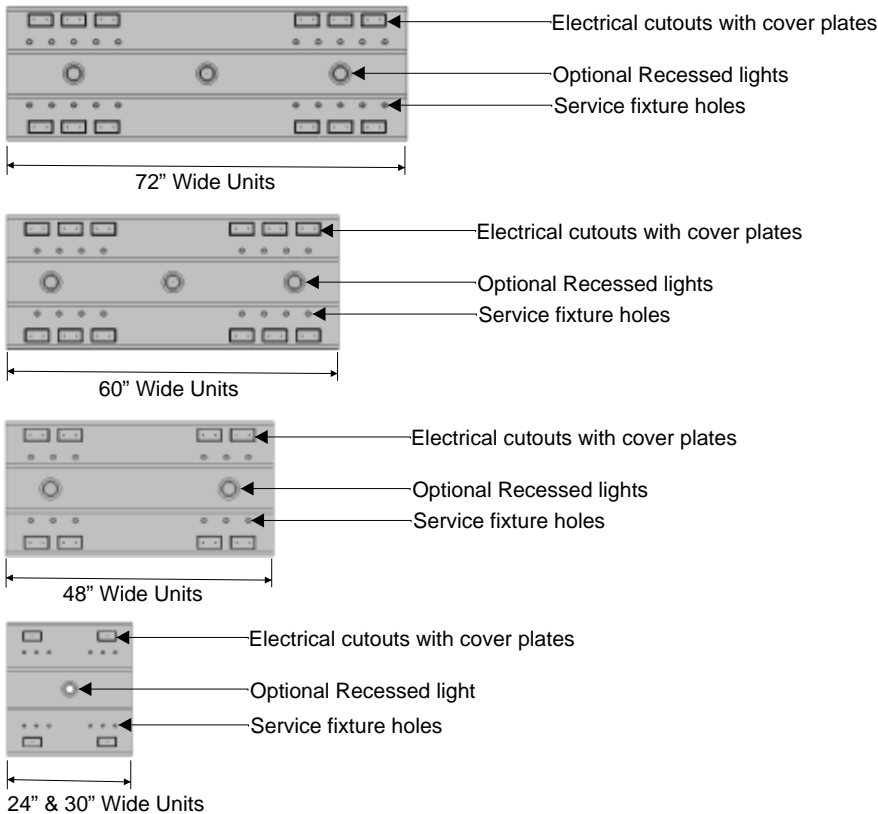

**Side View**

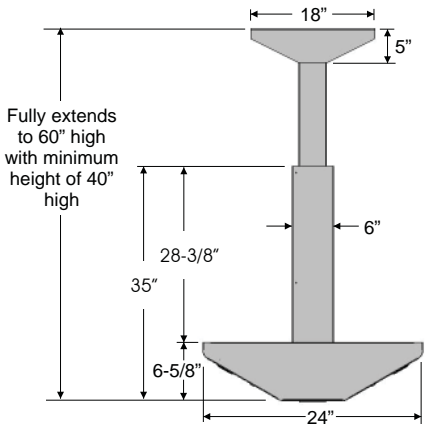

All dimensions and sizes shown are nominal. Specifications and details are based on product information at the time of printing and may change at any time without notice. Mott Manufacturing reserves the right to change dimensions, specifications and manufacturing details at any time without notice.

### MOBILITY OVERHEAD SERVICE CARRIERS

#### Suspended Chameleon™ Carriers



Width	With Lights	Without Lights
24"	OHC1024	OHC2024
30"	OHC1030	OHC2030
36"	OHC1036	OHC2036
48"	OHC1048	OHC2048
60"	OHC1060	OHC2060
72"	OHC1072	OHC2072

- Fixture holes are plugged with ABS plastic caps.
- Carrier Body is 6-5/8" high x 24" deep.
- Height adjustable in 1" increments.
- End Caps must be ordered separately.
- See page Q14 for configurations.

#### Center Panel Assemblies



Width	28-3/8" High
24"	OHP2429
30"	OHP3029
36"	OHP3629
48"	OHP4829
60"	OHP6029
72"	OHP7229

- Pair of filler panels are used to enclose space between ceiling assembly.
- Hardware to mount center panel is included.
- Suitable for Chameleon™ carrier only.

#### Carrier End Cap



Item Number
OHC0000

- Single end cover cap used to enclose uncovered ends of carrier body.
- Hardware to mount end cap is included.
- Suitable for Chameleon™ carrier only.

#### End Service Drop

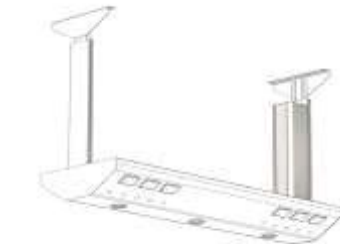

Option Code
SD

- Umbilical support structure used to carry utilities from the carrier body up through the ceiling.
- Dimensions 6" wide x 6" deep x 25-1/2" high.
- Removable service panel.
- Ships assembled.
- Suitable for Chameleon™ carrier only.

#### Connector Plate



Item Number
OHC1000

- Plate used to join two Chameleon™ carriers end to end.
- Mounting hardware not included.
- Suitable for Chameleon™ carrier only.

*MOBILITY  
OVERHEAD SERVICE CARRIERS*

**Flush Mounted Chameleon™**

Flush mounted Chameleons deliver ceiling fed utilities from ceiling tiles and are available in 24" x 24" or 24" x 48" dimensions. They can house utilities like piping, electric, data, light fixtures. They provide maximum flexibility as services are lifted off the floor, allowing free floor space to be configured as needed. Ideal for use with Sigma Carts™ as the quick disconnects allow for easy relocation.

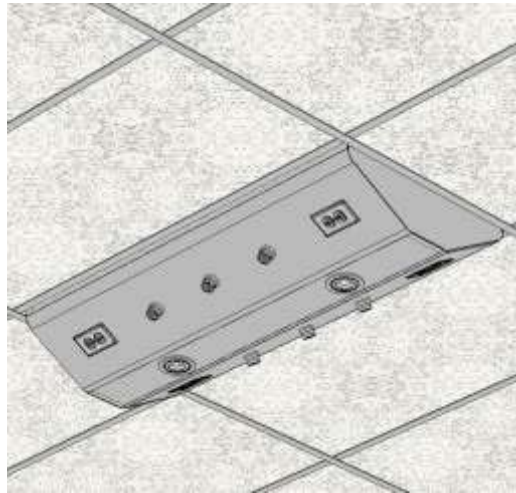

**Bottom Views**

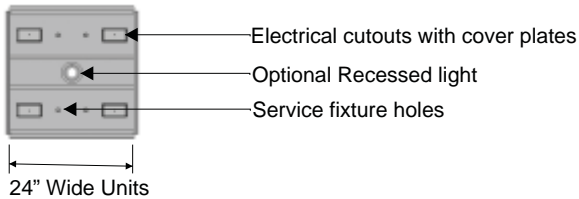
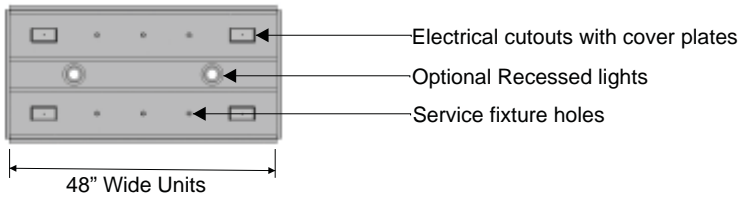

**Side View**

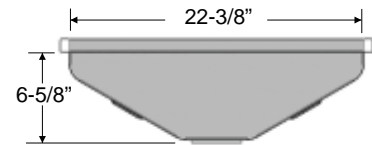

**Flush Mounted Chameleon™ Carriers**

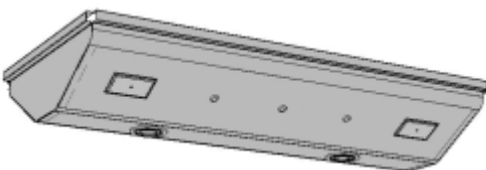

Size	With Lights	Without Lights
24"x24"	OHC3024	OHC4024
48"x24"	OHC3048	OHC4048

- Fixture holes are plugged with ABS plastic caps.
- Carrier Body is 6-5/8" high x 22-3/8" deep.
- One piece of unistrut is welded to inside of carrier frame for anchoring to support above.
- When pre-wired option is selected a 12 foot electrical whip is supplied.

*MOBILITY  
OVERHEAD SERVICE CARRIERS*

**Suspended Avion™**

The Avion™ houses all services such as electrical, data, telephone, local exhaust systems and light as well as all of the usual plumbing services. They provide maximum flexibility as services are lifted off the floor, allowing free floor space to be configured as needed. The Avion™ is designed to work off a grid supply system that allows the carrier to be easily relocated to a different section of the laboratory and can be ganged end to end in a continuous linear configuration.



**Bottom Views - without Lights**

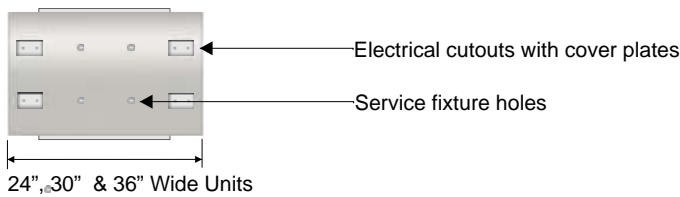
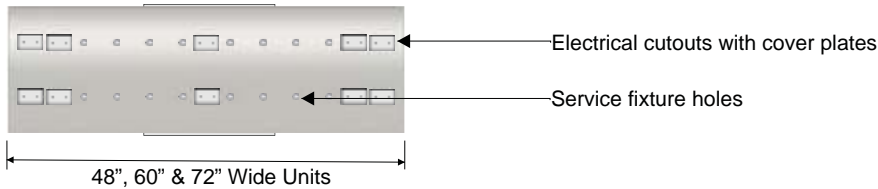

**Side View**

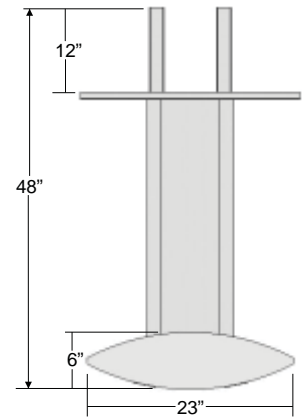

**Bottom Views - with Lights**

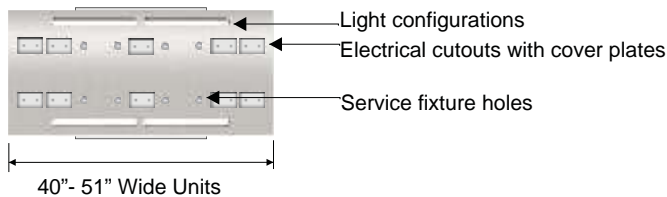
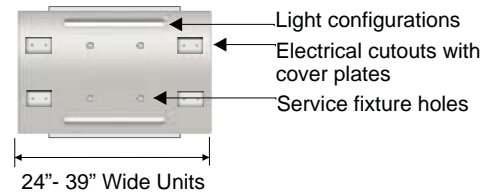
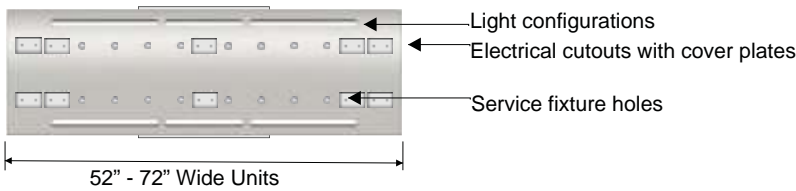



*MOBILITY  
OVERHEAD SERVICE CARRIERS*

**Suspended Avion™ Carriers**

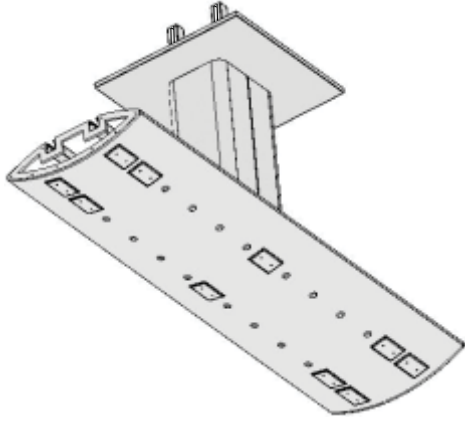

**Recommendation For Fastening:** Due to differences in structure and materials of ceiling, the best method mounting the overhead carrier(s) to the ceiling will be dictated by field conditions and determined by local engineers. Ceiling post assemblies should be secured to the contractor/installer provided bracing or framing. mounting hardware is supplied by the installer.

Width	With Lights	Without Lights
24"	OHA1024	OHA2024
30"	OHA1030	OHA2030
36"	OHA1036	OHA2036
48"	OHA1048	OHA2048
60"	OHA1060	OHA2060
72"	OHA1072	OHA2072

- Fixture holes are plugged with ABS plastic caps.
- Carrier body is 6" high x 23" deep.
- End Caps must be ordered separately.
- If wiring is ordered, 3' of electrical whip (above vertical column top) is provided.
- See page Q17 for service and electrical configurations.
- T5 fluorescent lights are included on OHA10xx part numbers.
- Add option code AC for Dust Cap for Avion™ Carrier.

**Carrier End Cap**

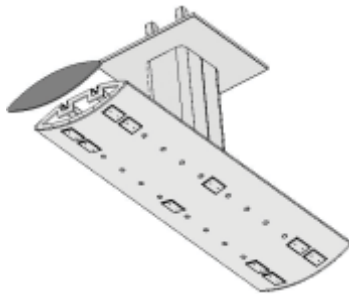

Item Number
OHA0000

- Single cover cap used to enclose uncovered ends of carrier body (Two end caps are required for each carrier, item number is for one end cap only).
- Hardware to mount end cap is included.
- Suitable for Avion™ carrier only.

**Connector Plates**

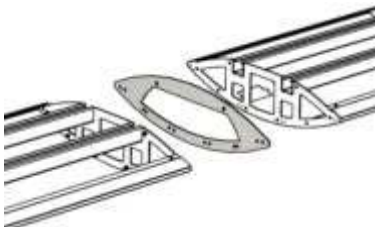

Item Number
OHA1000

- Plate used to join two Avion™ carriers end to end.
- Mounting hardware not included.
- Suitable for Avion™ carrier only.

**Mounting Brackets**



Item Number
OHA2000

- Brackets used to mount Avion™ carriers to building structure.
- Hardware to mount brackets to Avion™ included (no other hardware supplied).
- Suitable for Avion™ carrier only.



*MOBILITY  
CEILING SERVICE PANELS*

**Ceiling Service Panels**

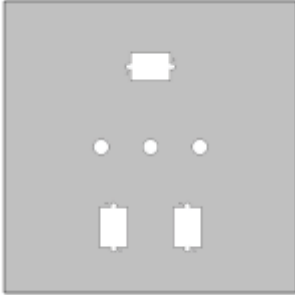

**Item Number**

OSP0001

- Powder coated steel panel takes the place of a standard ceiling tile.
- Offers the ability to mount and disconnect quick connect service fixtures, electrical and data outlets.
- Dimension 23-3/4" x 23-3/4".
- 3 service access holes and 3 electrical cutouts.
- Panel is compatible with most T grid acoustical suspended ceiling structures.
- Fixtures must be ordered separately.

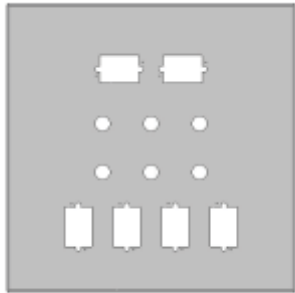

**Item Number**

OSP0002

- Powder coated steel panel takes the place of a standard ceiling tile.
- Offers the ability to mount and disconnect quick connect service fixtures, electrical and data outlets.
- Dimension 23-3/4" x 23-3/4".
- 6 service access holes and 6 electrical cutouts.
- Panel is compatible with most T grid acoustical suspended ceiling structures.
- Fixtures must be ordered separately.

### MOBILITY SPECIALTY CABINETS

#### Mobile Sink Cabinets

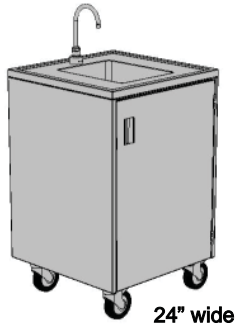
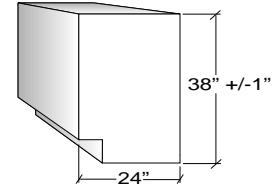

Width	Right Hinged	Left Hinged	# of Doors
24"	MS24011	MS24111	1
30"	MS30011	-	2
36"	MS36011	-	2
42"	MS42011	-	2
48"	MS48011	-	2

This cabinet provides a flexible supply of water in any research, school or care facility and can be used all through the facility when access to water is not available.

- Available in either type 304 stainless steel or powder coated steel with protective Sigma Barrier™ coating.
- Durable stainless steel worktop with raised perimeter marine edge with integrally welded sink allows for easy cleaning.
- Worktop provides a 1" overhang on all four sides
- Automatic faucet with infrared sensor provides hands-free operation.
- Plate mounted, non-marking 5" total lock swivel castors with santoprene rubber wheels allows the user to quickly and easily move to another work station, as tasks change.
- 5 US gallon fresh water container, 5 US gallon waste water container with drain spigot for easy release of waste water into the floor drain.
- Automatic pump provides up to 1.1 US gallons per minute with maximum current draw of 1.9 amperes at 12volt.
- Onboard sealed 12volt battery and 1.5amp automatic charger including 6' cord and plug. Manual power switch on cabinet side.
- Doors on front and back of cabinet provides convenient access for servicing.
- Shipped assembled and skidded.
- Use Option codes to add the following features:
  - ME (Manual Eyewash)
  - MF (Manual Faucet - use this option code if automatic faucet is not required).
  - WS (Supply hose to hook up with facility water supply, use this option code if fresh water tank and pump is not required).

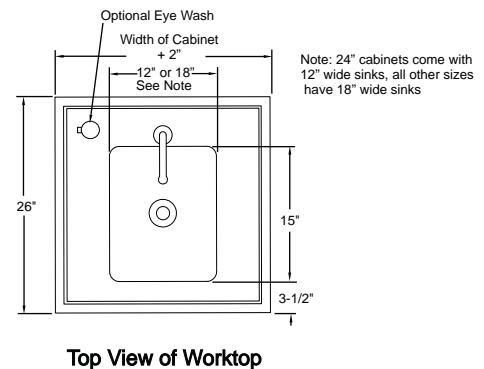
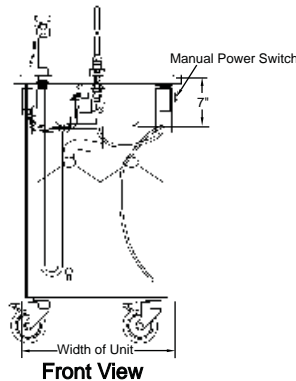
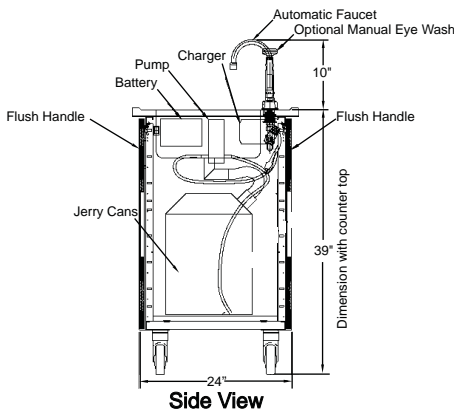

*MOBILITY  
ADAPTABLE LABORATORY FURNITURE SOLUTIONS*

**Heavy Duty Mobile Cart**

Heavy Duty Mobile Carts are ideal solutions to work stations that require high levels of durability, mobility, adjustability, and adaptability. These carts can be easily integrated either into existing work spaces or to locate them as independent self supporting work stations, which makes them ideal for sharing instrumentation, tools, or processes within the same laboratory area.

Full Height and Low Height Heavy Duty Mobile Carts are offered in various widths. Heavy Duty Mobile Carts can be configured with adjustable work surfaces, suspended lower cabinets and adjustable shelving.

Convenient height adjustment allows custom adaptation to specific operator and/or process requirements.



**Load Ratings**

Heavy Duty Mobile Cart assembly consists of cart frame, table frame and shelves (on Full Height Heavy Duty Mobile Carts only). Order suspended cabinets and work tops separately.

**Load Maximums**

Maximum load ratings are live loads and include loads applied to top of epoxy work surface, including total weight of epoxy shelves and suspended cabinetry and other accessories. These capacities should be used as guidelines only. Please contact Mott Manufacturing for specific load requirements. Maximum load ratings are based on the load being evenly balanced. Individual component or assembly load ratings should not be exceeded for any surface.

**Maximum Load Ratings Per Cart**

- Single work surface 1250lbs
- Middle Shelf 1000lbs
- Top Shelf 350lbs
- **Total Load Rating 2600lbs**

Total load rating is based on using epoxy shelves and work surfaces.  
For ordering suspended cabinets refer to that section in the catalog.

*MOBILITY  
SPECIALTY CARTS*

**Full Height Heavy Duty Mobile Cart**

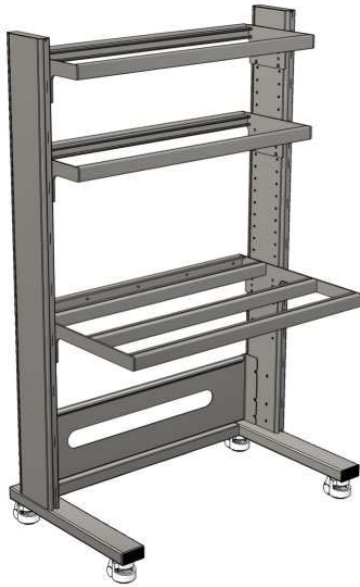

Width	Item Number
36"	HDC1036
48"	HDC1048
60"	HDC1060

- Full height table assembly is 76" high by 28" deep and comes complete with an adjustable table frame (work surface not included), two shelf frames, modesty panel and heavy duty casters.
- Overall depth with work surface is 30" with a 1" overhang front and back.
- Hanging rails are included on the table frame to suspend lower cabinets.
- Table frame and shelf frames are adjustable in 1" increments from 29" to 35".
- Add Option code VI for vibration isolators for Heavy Duty Cart. Note: with this option you cannot suspend cabinets.
- Shipped fully assembled.

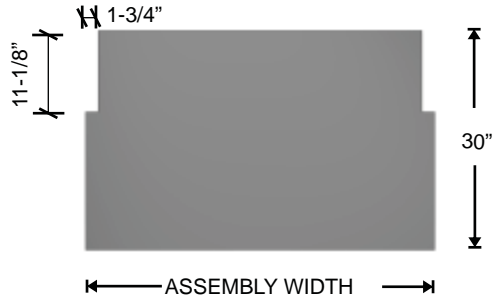

Typical Heavy Duty worksurface for 28" deep

**Low Height Heavy Duty Mobile Cart**



Width	Item Number
36"	HDC2036
48"	HDC2048
60"	HDC2060

- Low height table assembly is 36" high by 28" deep and comes complete with an adjustable table frame (work surface not included), modesty panel and heavy duty casters.
- Overall depth with work surface is 30" with a 1" overhang front and back.
- Hanging rails are included on the table frame to suspend lower cabinets.
- The table frame can be adjusted in 1" increments from 29" to 35".
- Add Option code VI for vibration isolators for Heavy Duty Cart. Note: With this option you cannot suspend cabinets.
- Shipped fully assembled.
- Add Option code VI for vibration isolators. Note: With this option you cannot suspend cabinets.

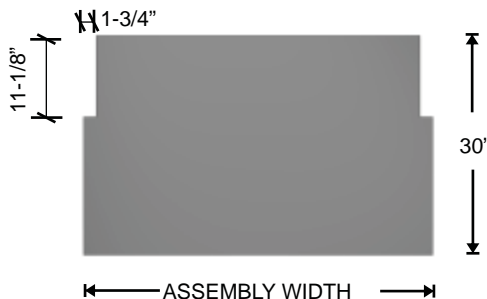

Typical Heavy Duty worksurface for 28" deep

*MOBILITY  
SPECIALTY CARTS*

**Shelf Frame**



Width of Workstation	Item Number
36"	SFA0036
48"	SFA0048
60"	SFA0060

- Self frame is suitable for Full Height Heavy Duty Mobile Cart only.
- Fully welded self frames are 16" deep with welded channels for ease of attaching accessories.

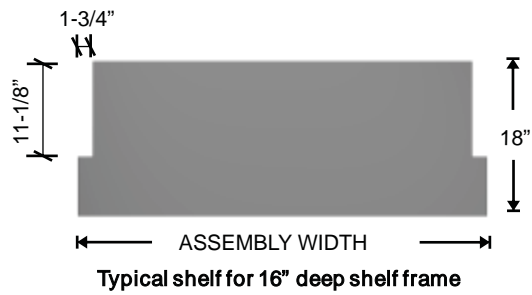

*OPTIMA™ MOBILE WORKSTATION  
MOBILE LABORATORY FURNITURE SOLUTIONS*

**Optima™ Mobile Workstation**

Mobile, adjustable and self contained workstations designed to enhance lab productivity. With a push of a button the work surface adjusts to meet the height demands of individual users and equipment. Add plumbing and shelving to meet your specific requirements. You can easily reconfigure lab layouts as needs change; simply move it where you need it, when you need to. The answer to flexibility to accommodate the ever-changing requirements in today's laboratories.



**Optima™ Mobile Workstation**  
Double Sided Assembly



**Optima™ Mobile Workstation**  
Single Sided Assembly

**For additional information and help in planning contact Mott Manufacturing.**

*OPTIMA™*  
*MOBILE WORKSTATION*

**Typical Assemblies**



**Double Sided Assembly  
with Fixtures and Shelving Options**



**Single Sided Assembly  
with Fixtures and Shelving Options**



**Double Sided Assembly**



**Single Sided Assembly**



*OPTIMA™  
MOBILE WORKSTATION*

**Parts List**

- 1) Optima™ Workstation Posts
  - 2) Optima™ Workstation Table Frame
  - 3) Optima™ Workstation Light Carrier Assembly
  - 4) Optima™ Workstation Lower Service Chase Assembly
  - 5) Optima™ Workstation Heavy Duty Casters
  - 6) Optima™ Workstation End Panels
- Note:** Drawing shown of a 60" wide Double Sided Assembly

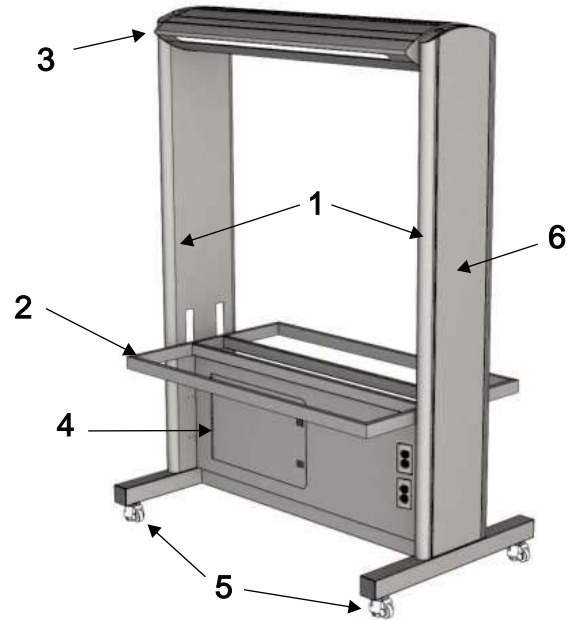

**Load Ratings**

**Load Maximums**

Maximum load ratings are live loads and include loads applied to top of work surface, including total weight of shelves. These capacities should be used as guidelines only. Please contact Mott Manufacturing for specific load requirements. Maximum load ratings are based on the load being evenly balanced on both sides and does not include the weight of the work surface. Individual component or assembly load ratings should not be exceeded for any surface.



**Single Sided Assembly**

**Maximum Load Ratings**

- **Adjustable Work Surface**
    - Cantilevered Work Surface 600lbs
  - **Shelving**
    - 15" deep Lower Shelf 100lbs
    - 15" deep Upper Shelf 100lbs
  - **Total Assembly**
    - Workstation 800lbs
- Includes one work surface at 600lbs, and any combination of shelves.



**Double Sided Assembly**

*OPTIMA™  
MOBILE WORKSTATION*

**Single Sided Assembly Circuit Details**

**STANDARD WIRING: 1 CIRCUIT**

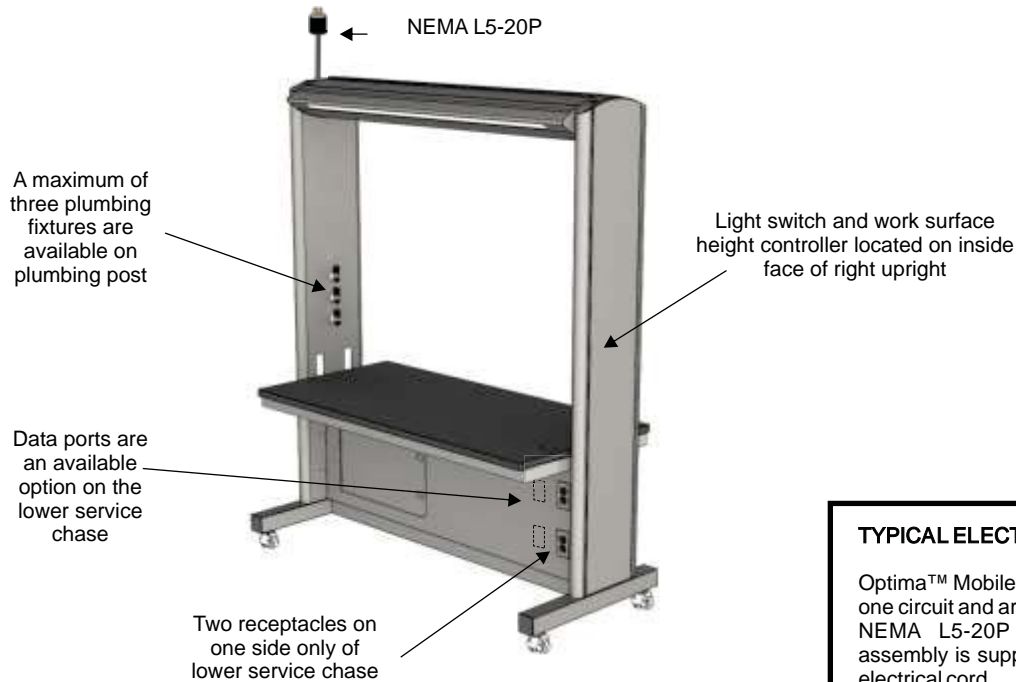

**TYPICAL ELECTRICAL PLUG DETAIL**

Optima™ Mobile Workstation comes with one circuit and are typically equipped with NEMA L5-20P locking plugs. Each assembly is supplied with 4 feet of black electrical cord.



**All electrical receptacles and data ports with cover are black.**

**Double Sided Assembly Circuit Details**

**STANDARD WIRING: 1 CIRCUIT**

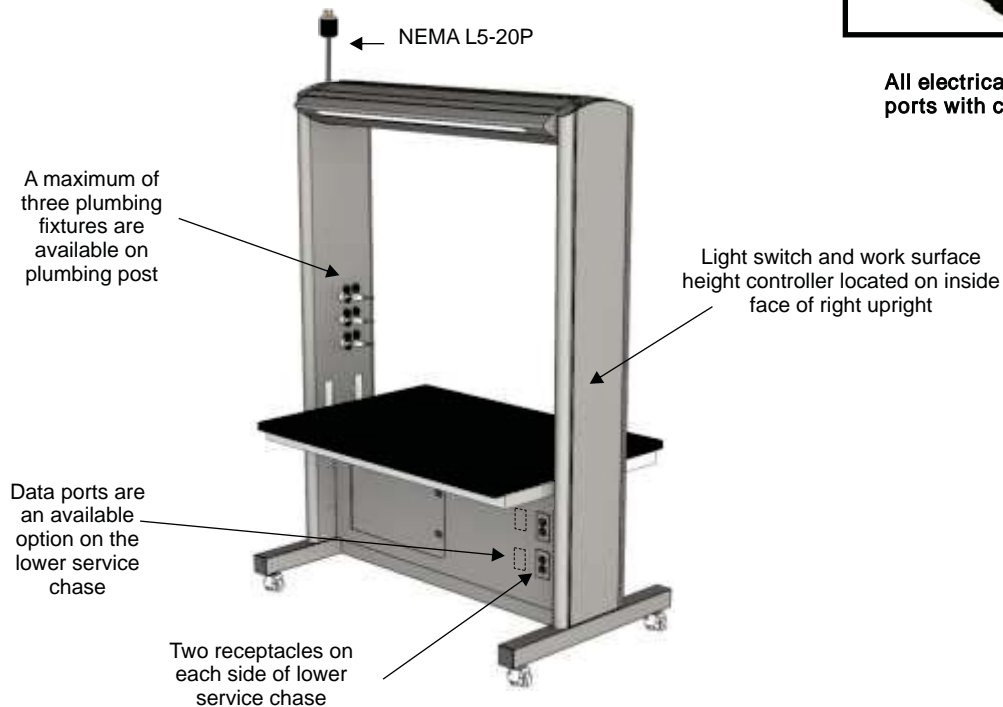

*OPTIMA™*  
*MOBILE WORKSTATION*

**Single Sided Assembly**

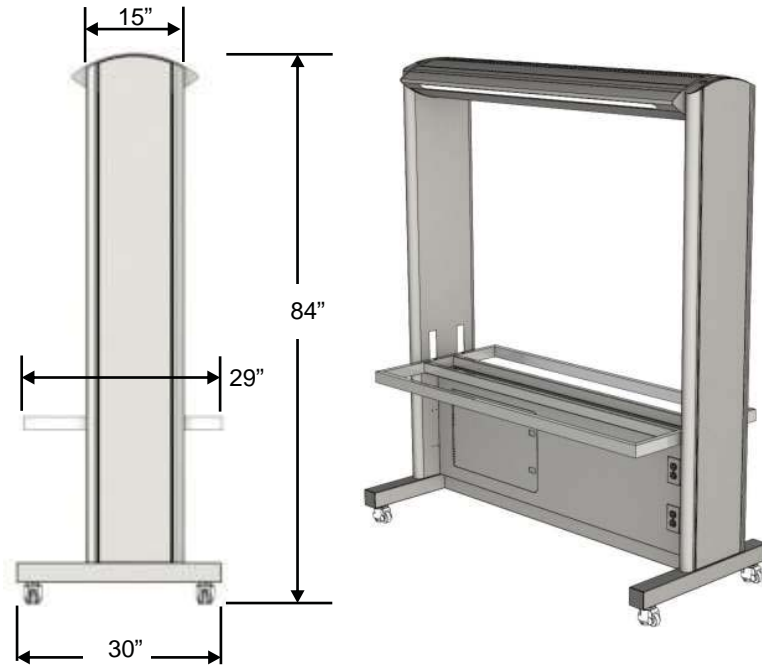

Width	Item Number
48"	OMW3048
60"	OMW3060
72"	OMW3072

- Workstation has a powder coated steel finish.
- Overall assembly is 84" high with 15" deep x 2-1/2" thick uprights. Overall depth of Single Sided Assembly is 30" deep (does not include work surface).
- Electro-hydraulic height adjustable table frame with electric motor has the flexibility to be raised or lowered from 29" to 35" (work surface not included).
- Complete with overhead task lights, light switch, two receptacles on lower service chase.
- Shipped assembled.

**Double Sided Assembly**

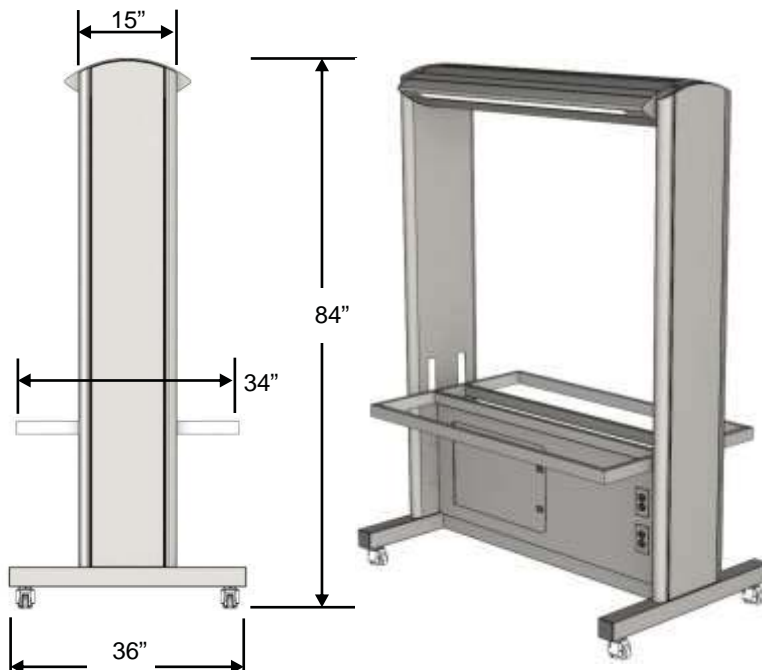

Width	Item Number
48"	OMW3648
60"	OMW3660
72"	OMW3672

- Workstation has a powder coated steel finish.
- Overall assembly is 84" high with 15" deep x 2-1/2" thick uprights. Overall depth of Double Sided Assembly is 36" deep (does not include work surface).
- Electro-hydraulic height adjustable table frame with electric motor has the flexibility to be raised or lowered from 29" to 35" (work surface not included).
- Complete with overhead task lights, light switch, four receptacles two per side on lower service chase.
- Shipped assembled.

*OPTIMA™  
MOBILE WORKSTATION SHELF COMPONENTS*

**Shelf Details**

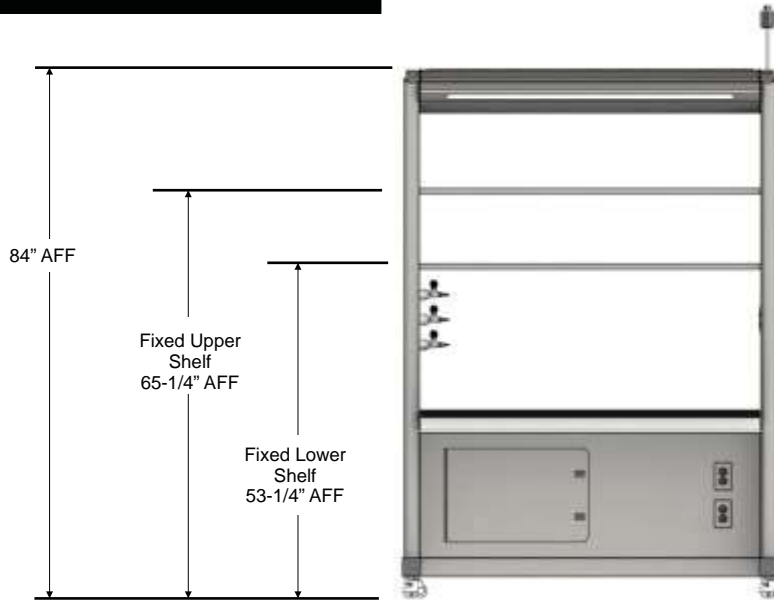

**Fixed Lower and Upper Shelves**



Lower Shelf

Upper Shelf

Upper and Lower Shelves

- Shelves are 1" thick and 12-1/2" deep.
- Shelves are in a fixed location and not height adjustable.
- Suitable for Optima™ Mobile Workstations only.
- Available in powder coated steel and stainless steel.
- Add option code:
  - O1 for Lower Shelf
  - O2 for Upper Shelf
  - O3 for Upper and Lower Shelf

**Retainer Rods For Shelves**

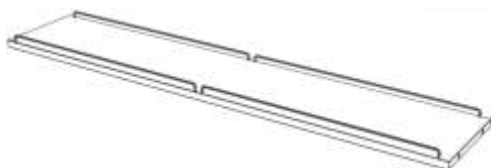

Retainer Rod Option Code	
Powder Coated	Stainless Steel
CR	SR

- 1" high retainer rod (5/16" dia.) prevents articles from falling off the shelf.
- 48" wide Workstations receive two retainer rods, one on each side. 60" and 72" wide Workstations receive four retainer rods, two on each side.
- Available in stainless steel or powder coated stainless steel.
- Retainer rods ship assembled on the shelf.

72" wide shelf shown.

*OPTIMA™*  
*MOBILE WORKSTATION*

**Work Surfaces**

Single Sided Assembly Work Surface (1" overhang at the front and back).

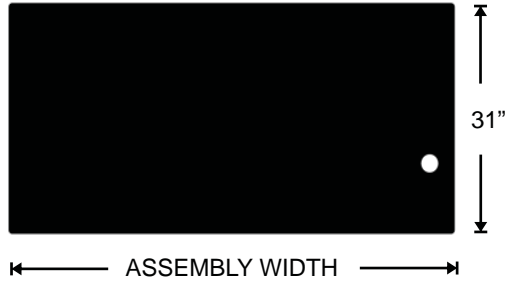

Single Sided Assembly Work Surface (1" overhang at front & back)		
Width of Workstation	Black Epoxy	Stainless Steel
	31" Deep	31" Deep
48"	EMS3148	SMS3148
60"	EMS3160	SMS3160
72"	EMS3172	SMS3172

- Stainless steel work surfaces are type 304-4, flat, square edges, stainless steel hat channel construction, 1" thick.
- Epoxy work surfaces are 1" thick.
- Wire management covers are not supplied with epoxy or stainless steel tops.

Double Sided Assembly Work Surface (1" overhang at the front and back).

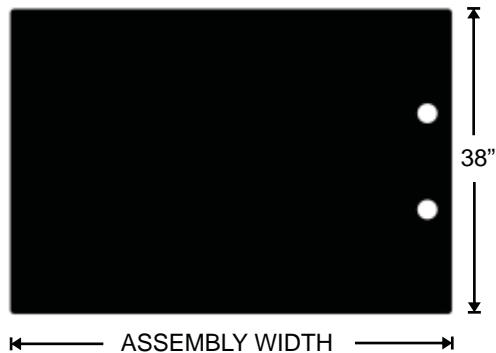

Double Sided Assembly Work Surface (1" overhang at front & back)		
Width of Workstation	Black Epoxy	Stainless Steel
	38" Deep	38" Deep
48"	EMD3848	SMD3849
60"	EMD3860	SMD3860
72"	EMD3872	SMD3872

- Stainless steel work surfaces are type 304-4, flat, square edges, stainless steel hat channel construction, 1" thick.
- Epoxy work surfaces are 1" thick.
- Wire management covers are not supplied with epoxy or stainless steel tops.



**OPTIMA™**

**SERVICE FIXTURES** - These parts are to be ordered if you require services to be shipped loose.

**Female Quick Connect Fittings**



For Coiled & PVC Hose		
Service	Band Color	Item Number
AIR	Orange	MCPVAIR
ARG	Violet	MCPVARG
CW	Green	MCPVCWT
GAS	Blue	MCPVGAS
HE	Black	MCPVHEL
NIT	Brown	MCPVNIT
VAC	Yellow	MCPVVAC

- These parts are to be ordered if you require services to be shipped loose.
- A panel mounted brass keyed quick connect body is suitable for panel mounting on overhead service carriers and Ceiling Service Panels with coiled and PVC hoses.
- Complete with a 3/8" male NPT inlet.
- Only plug and body quick connects of the same color will couple and allow flow.

**Coiled & PVC Hose Assemblies**

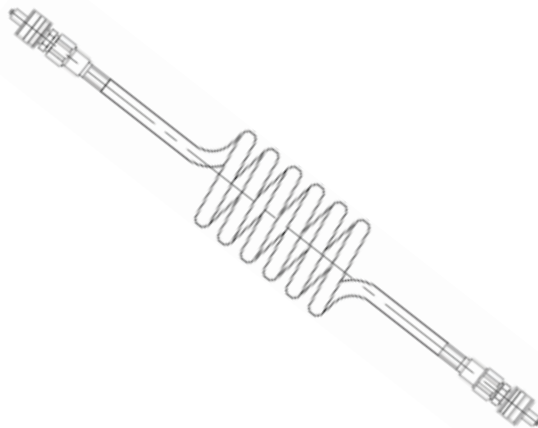

Coiled Hose		
Service	Band Color	Item Number
AIR	Orange	COHAIR
ARG	Violet	COHAARG
CW	Green	COHACWT
GAS	Blue	COHAGAS
HE	Black	COHAHEL
NIT	Brown	COHANIT
VAC	Yellow	COHAVAC

- These parts are to be ordered if you require services to be shipped loose.
- Assembly complete with 3/8" I.D. X 9/16" O.D. Coiled polyurathane hose (color of hose is translucent blue) and keyed plug quick connects.
- Suitable for all Optima™ series.
- Only plug and body quick connects of the same color will couple and allow flow.

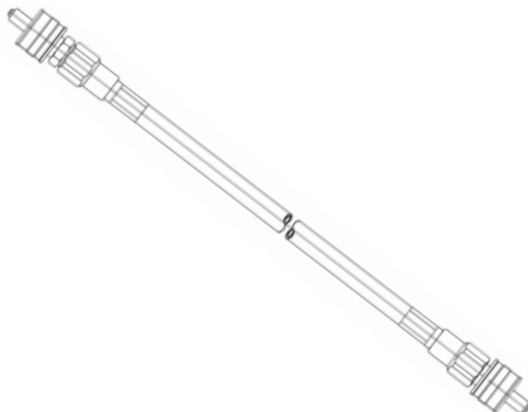

PVC Hose		
Service	Band Color	Item Number
AIR	Orange	PVHAIR
ARG	Violet	PVHAARG
CW	Green	PVHACWT
GAS	Blue	PVHAGAS
HE	Black	PVHAHEL
NIT	Brown	PVHANIT
VAC	Yellow	PVHAVAC

- These parts are to be ordered if you require services to be shipped loose.
- Assembly complete with 3/8" I.D. X 72" long reinforced PVC hose color-coded per service and keyed plug quick connects.
- Suitable for Optima™ series.
- Only plug and body quick connects of the same color will couple and allow flow.

**Note:** The above hoses may not be acceptable for use with Natural Gas in some jurisdictions. Please consult with the local authorities before ordering. Consult Mott for further information.

*OPTIMA™*

*SERVICE FIXTURES* - These parts are to be ordered if you require services to be shipped loose.

**Female Quick Connect Fittings**



For Stainless Steel Hose		
Service	Band Color	Item Number
AIR	Orange	MSSAAIR
ARG	Violet	MSSAARG
CW	Green	MSSACWT
GAS	Blue	MSSAGAS
HE	Black	MSSAHEL
NIT	Brown	MSSANIT
VAC	Yellow	MSSAVAC

- These parts are to be ordered if you require services to be shipped loose.
- A panel mounted stainless steel keyed quick connect body is suitable for panel mounting on overhead service carriers and Ceiling Service Panels with stainless steel hoses.
- Complete with 3/8" NPT inlet.
- Only plug and body quick connects of the same color will couple and allow flow.

**Stainless Steel Hose Assemblies**

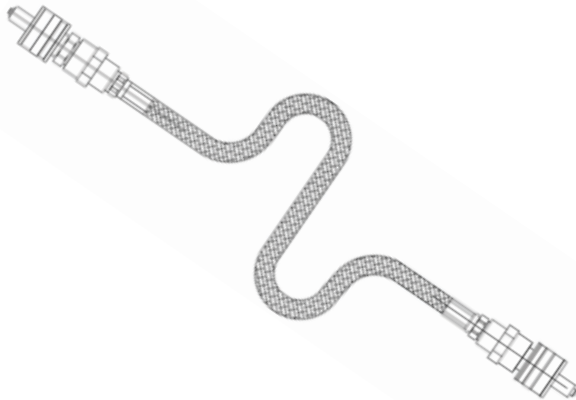

Stainless Steel Hose		
Service	Band Color	Item Number
AIR	Orange	SSHAIR
ARG	Violet	SSHAARG
CW	Green	SSHACWT
GAS	Blue	SSHAGAS
HE	Black	SSHAHEL
NIT	Brown	SSHANIT
VAC	Yellow	SSHAVAC

- These parts are to be ordered if you require services to be shipped loose.
- Assembly complete with 3/8" I.D. X 72" long stainless steel braided hose (hose has Teflon core) and stainless steel keyed plug quick connects.
- Suitable for Optima™ series.
- Only plug and body quick connects of the same color will couple and allow flow.

**Note:** The above hoses may not be acceptable for use with Natural Gas in some jurisdictions. Please consult with the local authorities before ordering. Consult Mott for further information.



**OPTIMA™**

**SERVICE FIXTURES** - These parts are to be ordered if you require services to be shipped loose.

**Quick Connect Valve Assemblies**

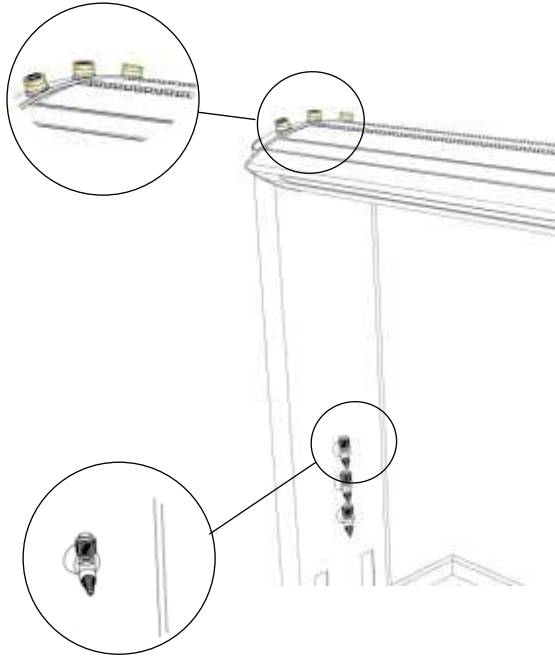

Single Sided Workstation			
Service	Band Color	For Coiled & PVC Hose	For Stainless Hose
AIR	Orange	QCV1AIR	QCV3AIR
ARG	Violet	QCV1ARG	QCV3ARG
CW *	Green	QCV1CWT	QCV3CWT
GAS	Blue	QCV1GAS	QCV3GAS
HE	Black	QCV1HEL	QCV3HEL
NIT	Brown	QCV1NIT	QCV3NIT
VAC	Yellow	QCV1VAC	QCV3VAC

- These parts are to be ordered if you require services to be shipped loose.
- Assembly complete with panel mounted single service fixture (Instrumentation Needle Valve supplied, Note: \* Cold Water is supplied with ball valve), keyed quick connect body and tubing.
- When ordering assembly for Coiled & PVC hose, brass keyed quick connect body and copper tubing is supplied. When ordering assembly for stainless steel hose, stainless steel keyed quick connect body and stainless steel tubing is supplied.
- This assembly is only suitable for Optima™ Mobile Workstation and Optima™ 2100 series.
- Only plug and body quick connects of the same color will couple and allow flow.

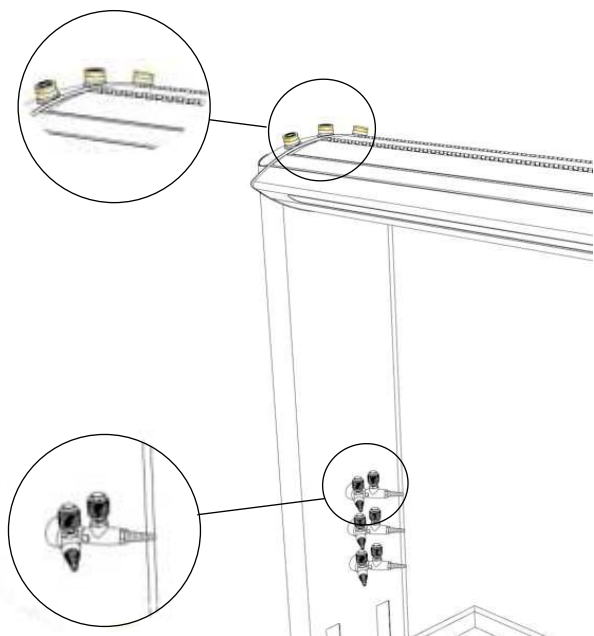

Double Sided Workstation			
Service	Band Color	For Coiled & PVC Hose	For Stainless Hose
AIR	Orange	QCV2AIR	QCV4AIR
ARG	Violet	QCV2ARG	QCV4ARG
CW *	Green	QCV2CWT	QCV4CWT
GAS	Blue	QCV2GAS	QCV4GAS
HE	Black	QCV2HEL	QCV4HEL
NIT	Brown	QCV2NIT	QCV4NIT
VAC	Yellow	QCV2VAC	QCV4VAC

- These parts are to be ordered if you require services to be shipped loose.
- Assembly complete with panel mounted wye service fixture (Instrumentation Needle Valve supplied, Note: \* Cold Water is supplied with ball valve), keyed quick connect body and tubing.
- When ordering assembly for Coiled & PVC hose, brass keyed quick connect body and copper tubing is supplied. When ordering assembly for stainless steel hose, stainless steel keyed quick connect body and stainless steel tubing is supplied.
- This assembly is only suitable for Optima™ Mobile Workstation Optima™ 2500 series.
- Only plug and body quick connects of the same color will couple and allow flow.
- Service fixtures for the Single Sided Workstation have one side capped off.

*ALTUS™ TABLE SYSTEM  
ADAPTABLE LABORATORY FURNITURE SOLUTIONS*

**Altus™ Table System**

The Altus™ table system is designed to adapt to an array of laboratory processes, equipment and users. It conveniently supplies all the services and features required for today's laboratory in a self-contained and self-standing bench assembly. This stylish system is available in powder coated steel finish or stainless steel.

With Altus™, laboratories can be easily created, changed and reconfigured for new applications or changing space. Integrated services deliver quick and easy access while providing superior flexibility by keeping the work surface open. Plumbing and electrical services are factory installed and designed to quick connect to ceiling mounted service panels or overhead service carriers.

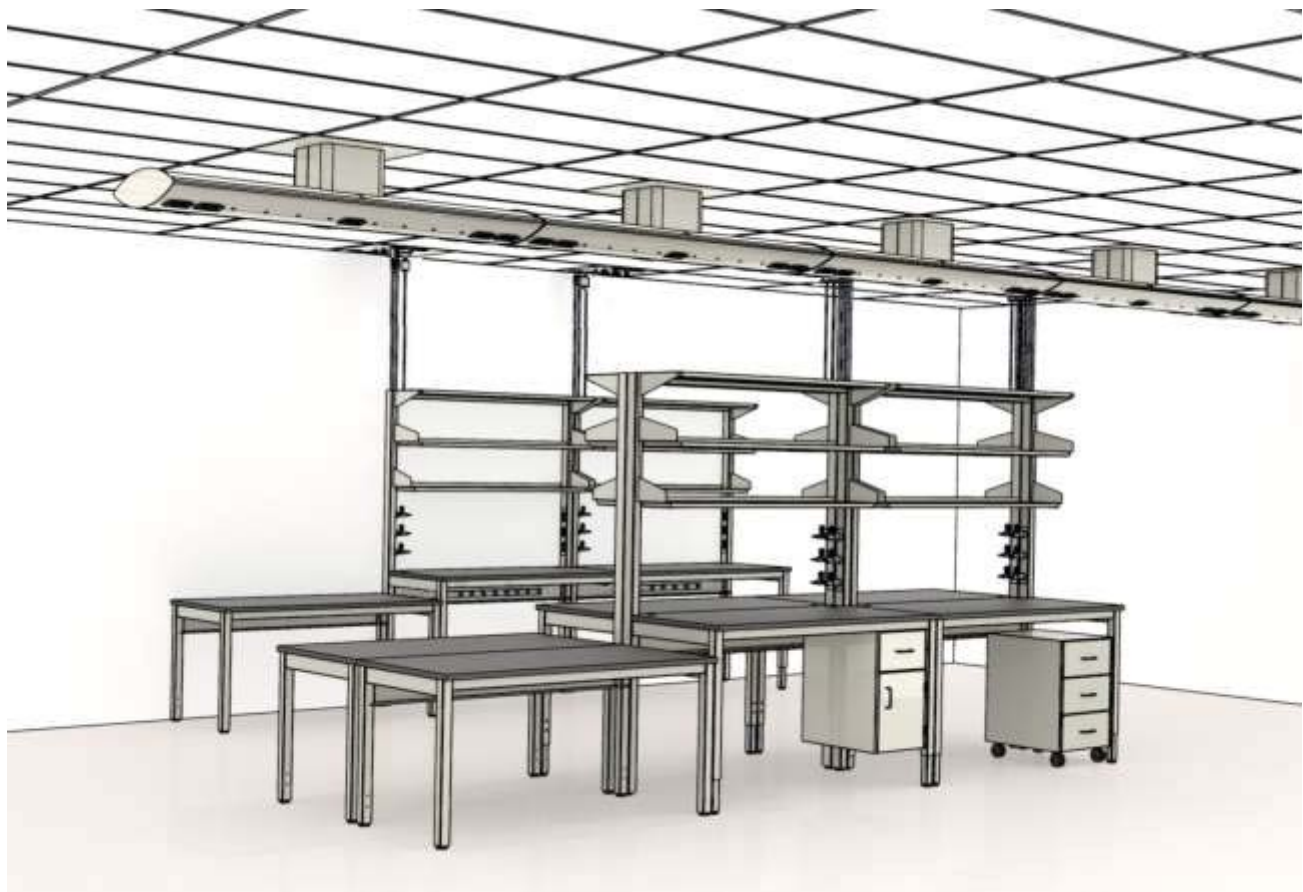

**For additional information and help in planning contact Mott Manufacturing.**

*ALTUS™  
TABLE SYSTEM*

**Typical Assemblies**



**Full Height Assembly**



**Stationary Table**

*ALTUS™  
TABLE SYSTEM*

**Circuit Details**

**STANDARD WIRING**

Option code "D1": 1 CIRCUIT  
48", 60", 72" WIDE ASSEMBLY

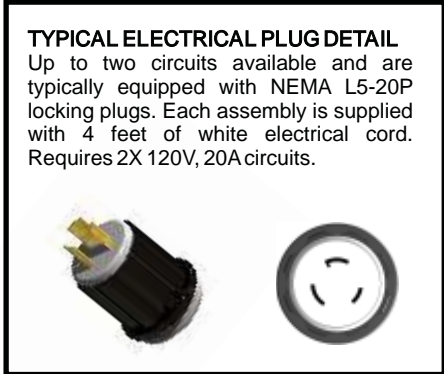
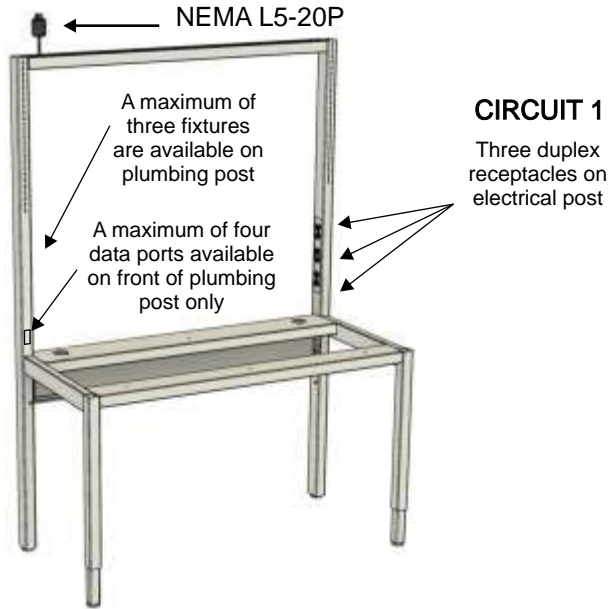

All electrical receptacles and data are white.

**WIRING OPTION A**

Option code "D2": 2 CIRCUITS  
48", 60", 72" WIDE ASSEMBLY

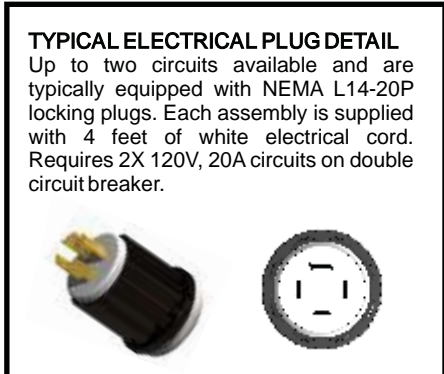
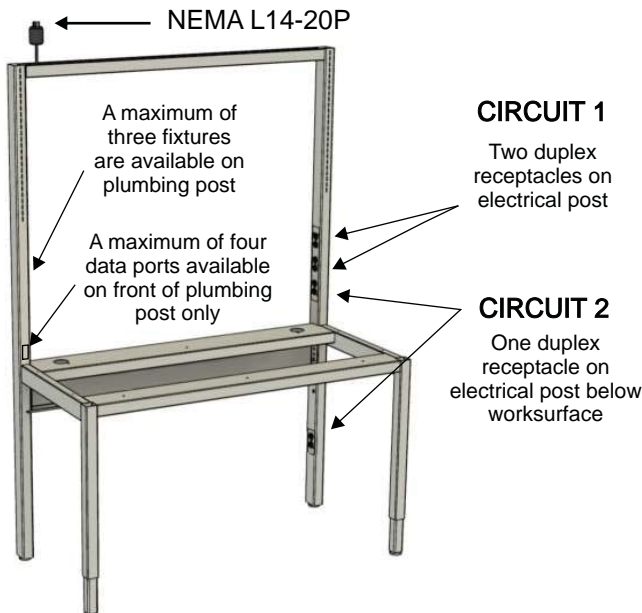

All electrical receptacles and data are white.

*ALTUS™  
TABLE SYSTEM*

**Assembly**



Width	23" Deep	29" Deep
48"	ATS2348	ATS2948
60"	ATS2360	ATS2960
72"	ATS2372	ATS2972

- Available in powder coated steel finish or stainless steel.
- Overall assembly is 84" high, 2" X 3" deep rear posts, 2" square tubular front legs with leveling feet. Table frame is an all-welded construction. Cantilevered table frame is height adjustable in 1" increments from 29" to 36" (work surface not included).
- Complete with hanging rails to suspend lower cabinets on units 72" wide and smaller.
- Standard depth hanging cabinets are not suitable for 23" deep tables.
- To order suspended base cabinets, mobile cabinets, pencil drawers and pull out writing tablets refer to those catalog sections.
- A maximum of three fixtures are available on the plumbing post.
- Three duplex electrical receptacles are standard on side electrical post (data an available option).
- Overall depth of assembly does not include work surface.
- Shipped partially assembled.

**Four Leg Table**



Width	22" Deep	28" Deep
48"	ATF2248	ATF2848
60"	ATF2260	ATF2860
72"	ATF2272	ATF2872

- Available in powder coated steel finish or stainless steel.
- Table frame is an all-welded construction. 2" square tubular legs with leveling feet. Table frame is height adjustable in 1" increments from 29" to 36" (work surface not included).
- Table frame complete with hanging rails to suspend lower cabinets.
- Standard depth hanging cabinets are not suitable for 22" deep tables.
- To order suspended base cabinets, mobile cabinets, pencil drawers and pull out writing tablets refer to those catalog sections.
- Shipped assembled.

*ALTUS™*  
*TABLE SYSTEM*

**Work Surfaces**

Four Leg Table Work Surface for 22" deep or 28" deep units (1" overhang at the front and back).



Four Leg Table Work Surface (1" overhang at front & back)				
Width of Bench	Black Epoxy		Stainless Steel	
	24" Deep	30" Deep	24" Deep	30" Deep
48"	EAT2448	EAT3048	SAT2448	SAT3048
60"	EAT2460	EAT3060	SAT2460	SAT3060
72"	EAT2472	EAT3072	SAT2472	SAT3072

- Stainless steel work surfaces are type 304-4, flat, square edges, stainless steel hat channel construction, 1" thick.
- Epoxy work surfaces are 1" thick.

Work Surface for 23" deep and 29" deep units (1" overhang at front).

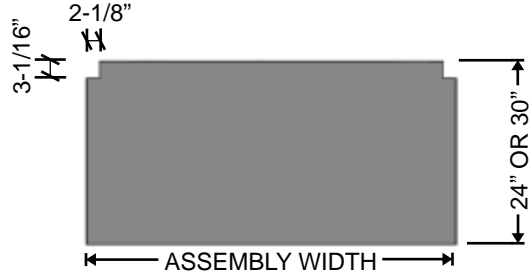

Single Sided Assembly Work Surface (1" overhang at front)				
Width of Bench	Black Epoxy		Stainless Steel	
	24" Deep	30" Deep	24" Deep	30" Deep
48"	EAL2448	EAL3048	SAL2448	SAL3048
60"	EAL2460	EAL3060	SAL2460	SAL3060
72"	EAL2472	EAL3072	SAL2472	SAL3072

- Stainless steel work surfaces are type 304-4, flat, square edges, stainless steel hat channel construction, 1" thick.
- Epoxy work surfaces are 1" thick.

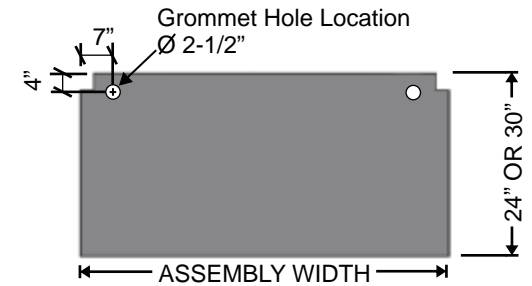

Single Sided Assembly Work Surface with Grommet Holes (1" overhang at front)				
Width of Bench	Black Epoxy		Stainless Steel	
	24" Deep	30" Deep	24" Deep	30" Deep
48"	EAH2448	EAH3048	SAH2448	SAH3048
60"	EAH2460	EAH3060	SAH2460	SAH3060
72"	EAH2472	EAH3072	SAH2472	SAH3072

- Grommet hole cutout available in work surface when lower raceway option is ordered.
- Stainless steel work surfaces are type 304-4, flat, square edges, stainless steel hat channel construction, 1" thick.
- Epoxy work surfaces are 1" thick.

*ALTUS™*  
*STEEL SHELF COMPONENTS*

**Altus™ Steel Shelf Assembly**

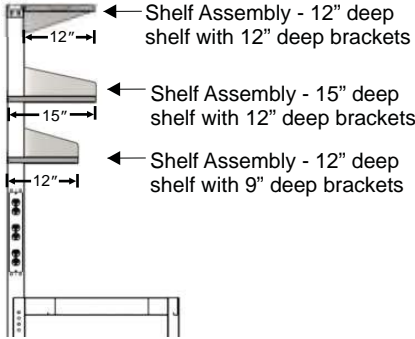

**Top Steel Shelf Assemblies**

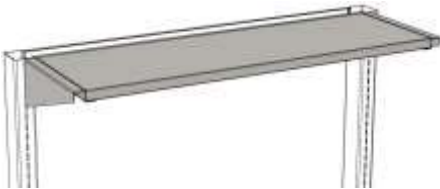

Width of Bench	Item Number
48"	AAS1248
60"	AAS1260
72"	AAS1272

- Assembly includes one 1" thick 12" deep shelf and a pair of 12" deep brackets. Also available in stainless steel.
- Shelves are adjustable in 1" increments.
- Suitable for Altus™ only.

**Steel Shelf Assemblies**



Width of Bench	12" Deep Shelf Assembly	15" Deep Shelf Assembly
48"	SAA1248	SAA1548
60"	SAA1260	SAA1560
72"	SAA1272	SAA1572

- Assembly includes one 1" thick shelf, one rear shelf angle, one 12" deep or 15" deep shelf and a pair of brackets. (9" brackets for 12" deep assembly, 12" deep brackets for 15" deep assembly). Also available in stainless steel.
- Shelves are adjustable in 1" increments.
- Suitable for Altus™ only.

**Retainer Rods For Shelf Assemblies**

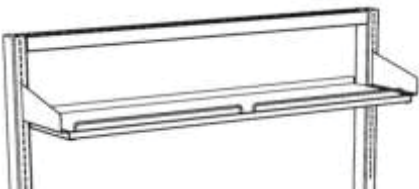

Retainer Rod Option Code	
Powder Coated	Stainless Steel
CR	SR

- 1" high retainer rod (5/16" dia.) prevents articles from falling off the shelf.
- Shelves receive two retainer rods on 48" wide and 60" wide shelves and three on 72" wide shelves.
- Available in stainless steel or powder coated stainless steel.
- Retainer rod ships assembled on the shelf.



*ALTUS™  
WOOD SHELVING COMPONENTS*

**Altus™ Wood Shelves**

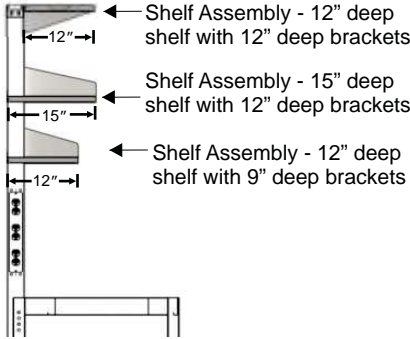

**Wood Shelves for 12" Deep Top Shelf Brackets**



Width of Bench	Item Number
48"	AAS1248W
60"	AAS1260W

- ∞ Shelves are 1" thick.
- ∞ Shelves are suitable for Altus™ only.
- ∞ Shelf brackets are not included and must be ordered separately.
- ∞ To add wood lips or valances to shelves see page R8 for option codes.
- ∞ 72" wide wood shelves not available.
- ∞ See page R8 for non-Mott shelf dimensions.

**Top Shelf Brackets**



Depth	Item Number
12"	TBA0012

- One pair of powder coated steel end brackets for Top Shelves. Designed to be used for shelves of different materials, mounts to slotted post. Available in stainless steel.
- Adjustable in 1" increments.
- Suitable for Altus™ only.
- See page R8 for non-Mott shelf dimensions.

**Wood Shelves for 9" Deep and 12" Deep Shelf Brackets**



Width of Bench	Shelves for 9" Bracket	Shelves for 12" Bracket
48"	SAA1248W	SAA1548W
60"	SAA1260W	SAA1560W

- ∞ Shelves are 1" thick.
- ∞ Shelves are suitable for Altus™ only.
- ∞ Shelf brackets are not included and must be ordered separately.
- ∞ To add wood lips or valances to shelves see page R8 for option codes.
- ∞ 72" wide wood shelves not available.

**Shelf Brackets**

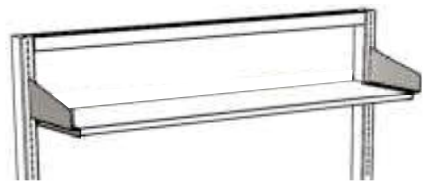

Depth	Item Number
9"	SBA0009
12"	SBA0012

- One pair of powder coated steel end brackets designed to be used for shelves of different materials, mounts to slotted post. Available in stainless steel.
- Adjustable in 1" increments.
- Suitable for Altus™ only.
- See page R8 for non-Mott shelf dimensions.

All dimensions and sizes shown are nominal. Specifications and details are based on product information at the time of printing and may change at any time without notice. Mott Manufacturing reserves the right to change dimensions, specifications and manufacturing details at any time without notice.

*ALTUS™  
SHELF COMPONENTS*

**Wood Shelving Options**

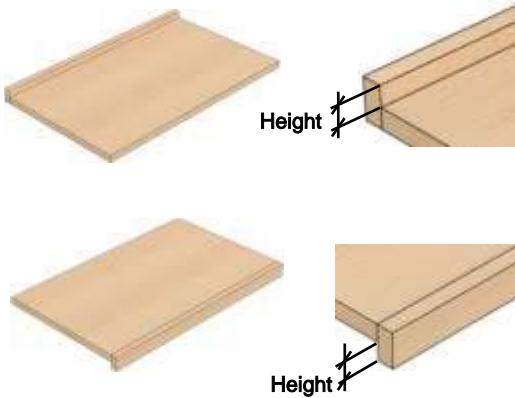

Height	Back Lip	Front Lip	Back and Front Lip
1"	ARW1	AFW1	ABW1
2"	ARW2	AFW2	ABW2
3"	ARW3	AFW3	ABW3
4"	ARW4	AFW4	ABW4

- Height of the lip is measured from the top of the shelf to the top of the lip. Lip is 3/4" thick.
- Shelves are 1" thick.

Height	Front Valance
1"	FV1
2"	FV2
3"	FV3
4"	FV4

- Height of the valance is measured from the bottom of the shelf to the bottom of the valance. Valance is 3/4" thick.
- Shelves are 1" thick.

**Retainer Rods For Shelf Assemblies**

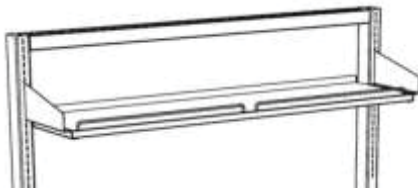

Retainer Rod Option Code	
Powder Coated	Stainless Steel
CR	SR

- 1" high retainer rod (5/16" dia.) prevents articles from falling off the shelf.
- Shelves receive two retainer rods on 48" wide and 60" wide shelves.
- Available in stainless steel or powder coated stainless steel.
- Retainer rods ships assembled on the shelf.

**Metal Shelf Angles**



Width of Bench	Item Number	Shelf Angles included
48"	ARS2148	1
60"	ARS2160	1
72"	ARS2172	1

- Metal shelf angles can be added to any existing Altus™ shelf and are used to stop items from sliding off of shelving.
- 2" high with a 1" return and notched for shelf brackets. Also available in stainless steel.
- Ships loose.

**Dimensions for Non-Mott Shelf on a 9" Bracket**

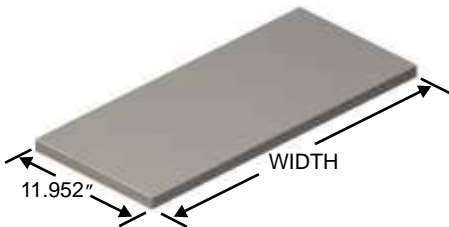

- Typical shelf dimensions for non-Mott shelves:**
- Quantity of 1 - 43.550" wide shelf is suits a 48" wide
  - Quantity of 1 - 55.550" wide shelves suits a 60" wide
  - Quantity of 1 - 67.550" wide shelves suits a 72" wide

**Dimensions for Non-Mott Shelf on a 12" Bracket**

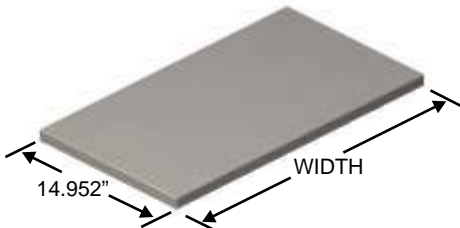

- Typical shelf dimensions for non-Mott shelves:**
- Quantity of 1 - 43.550" wide shelf is suits a 48" wide
  - Quantity of 1 - 55.550" wide shelves suits a 60" wide
  - Quantity of 1 - 67.550" wide shelves suits a 72" wide

*ALTUS™*  
COMPONENTS

**Undermount Shelf Task Lights**

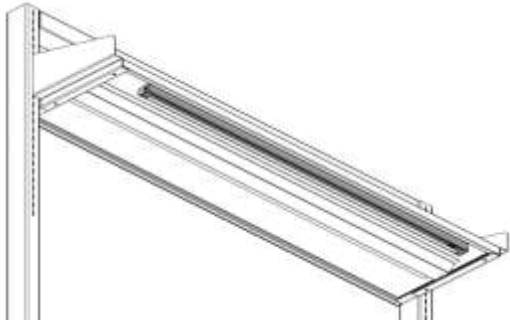

Length of Light	Item Number
14"	TLW0014
23"	TLW0023
36"	TLW0036
48"	TLW0048
59"	TLW0059

- **Order light a minimum 6" shorter than the shelf.** For shelf dimensions refer to page S12 for 2500 series and S22 for 2100 series .
- Low profile (.98" wide by 1.65" high) T5 white fluorescent task light mounts to underside of the shelf.
- Task light to be plugged into the Optima™ raceway.
- Shatterproof polycarbonate lens protects the lamp.
- Easily linkable in one continuous line using Flexible Connectors. 12" Flexible Connector and 6' power plug comes standard with each light. See below to order longer Flexible Connectors.
- On-off rocker switch located on the side of the fixture.
- 8000 hour, cool white replaceable T5 lamp included.
- UL listed.
- Ships loose, includes Mott's mounting brackets.

**Task Light Flexible Connectors**



Width	Item Number
12"	LFC0012
24"	LFC0024
36"	LFC0036

- Flexible Connector allows to easily link T5 fluorescent lights in one continuous line.

**LCD Monitor Arms**

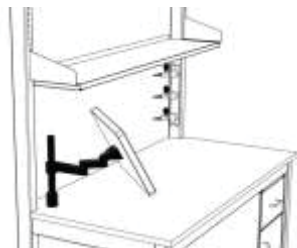

Item Number	
Anodized Silver Finish	Black Finish
MONARMS	MONARMB

- Position your LCD for maximum productivity and comfort.
- Features foldable arms which adjust vertically up and down a 12" pole. The arms can fold up to fit in about 3" of space and extend out 14". Rotates 360 degrees at three joints, monitor tilting mechanism can tilt over 200 degrees and adjustable tension at joints which is ideal for touch-screen applications.
- Weight capacity adjusts to hold up to 40lbs (Monitor depth greater than 2" may diminish capacity). Monitor not included.
- Easily attaches to LCDs that are VESAMIS-D, 100/75, compliant.
- Ships loose.

*ALTUS™  
COMPONENTS*

**Back-To-Back Fastener Kit**

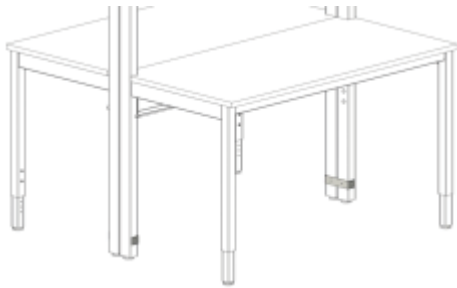

<b>Item Number</b>
ABF0000

- Bracket attaches to the bottom of the rear post legs to stabilize two assemblies that are situated back-to-back.
- Kit available in stainless steel.
- Hardware not included.
- Suitable for Altus™ only.

**Side-To-Side Fastener Kit**

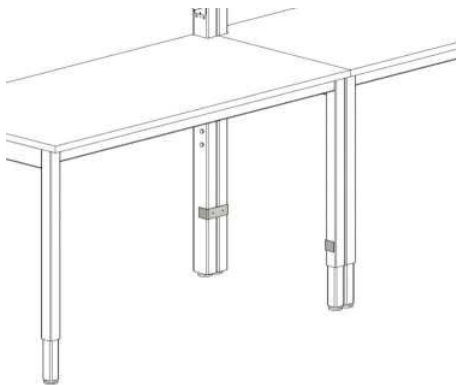

<b>Item Number</b>
ASF0000

- Bracket attaches to the bottom of the rear post legs to stabilize two assemblies that are situated side-to-side.
- Kit available in stainless steel.
- Hardware not included.
- Suitable for Altus™ only.

**Ceiling Service Panels**

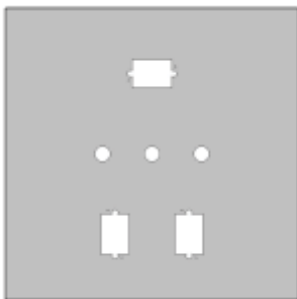

<b>Item Number</b>
OSP0001

- Powder coated steel panel takes the place of a standard ceiling tile.
- Offers the ability to mount and disconnect quick connect service fixtures, electrical and data outlets.
- Dimension 23-3/4" x 23-3/4".
- 3 service access holes and 3 electrical cutouts.
- Panel is compatible with most T grid acoustical suspended ceiling structures.
- Fixtures must be ordered separately.

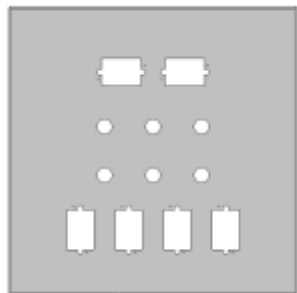

<b>Item Number</b>
OSP0002

- Powder coated steel panel takes the place of a standard ceiling tile.
- Offers the ability to mount and disconnect quick connect service fixtures, electrical and data outlets.
- Dimension 23-3/4" x 23-3/4".
- 6 service access holes and 6 electrical cutouts.
- Panel is compatible with most T grid acoustical suspended ceiling structures.
- Fixtures must be ordered separately.

**LABORATORY FURNITURE**

The customer is responsible for ensuring that internal piping and components meet local codes and standards. In some jurisdictions on-site inspection and testing may be required, this service is not provided by Mott Manufacturing.

*ALTUS™*

*SERVICE FIXTURES* - These parts are to be ordered if you require services to be shipped loose.

**Female Ceiling Quick Connect Fittings**



Service	Band Color	PVC Hose
		Item Number
AIR	Orange	MCPVAIR
ARG	Violet	MCPVARG
CW	Green	MCPVCWT
GAS	Blue	MCPVGAS
HE	Black	MCPVHEL
NIT	Brown	MCPVNIT
VAC	Yellow	MCPVVAC

- These parts are to be ordered if you require services to be shipped loose.
- A panel mounted stainless steel keyed quick connect body is suitable for panel mounting on overhead service carriers and Ceiling Service Panels with stainless steel hoses.
- A panel mounted brass keyed quick connect body is suitable for panel mounting on overhead service carriers and Ceiling Service Panels with PVC hoses.
- Complete with 3/8" NPT inlet.
- Only plug and body quick connects of the same color will couple and allow flow.

**Service Assemblies**

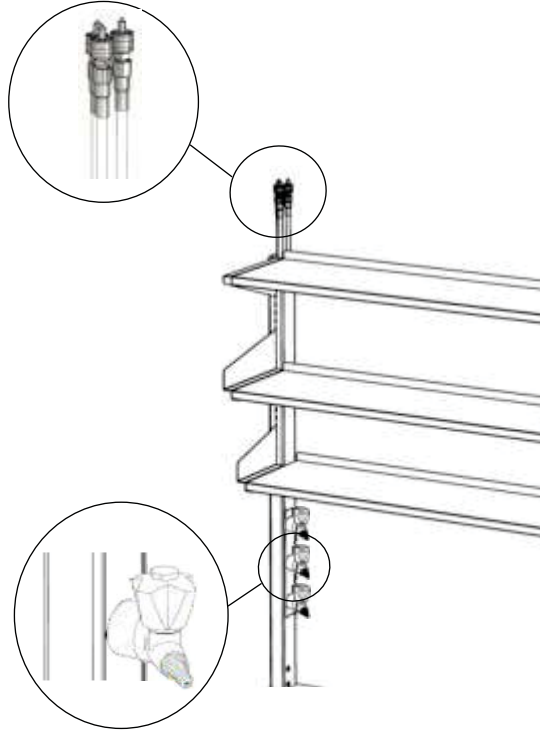

Altus™			
Service	Band Color	White PVC Hose	Stainless Hose
AIR	Orange	ASAPAIR	-
ARG	Violet	ASAPARG	-
CW *	Green	ASAPCWT	-
GAS	Blue	-	ASASGAS
HE	Black	ASAPHEL	-
NIT	Brown	ASAPNIT	-
VAC	Yellow	ASAPVAC	-

- These parts are to be ordered if you require services to be shipped loose.
- Assembly complete with panel mounted single service fixture (Instrumentation Needle Valve supplied, Note: \* Cold Water is supplied with ball valve), keyed quick connect plug and hose.
- Corrugated gas appliance connector with stainless steel keyed quick connect is supplied for natural gas.
- These assemblies are only suitable for the Altus™ Tables.
- Supplied with 4 feet of service lines above table height.
- Only plug and body quick connects of the same color will couple and allow flow.
- Fixtures may not be exactly as shown.
- Epoxy coated fixtures.

*STEEL TABLES*  
*TABLES*

**Stainless Steel Table Assemblies**



48" wide table shown

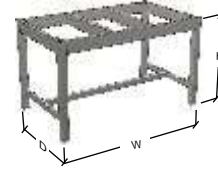
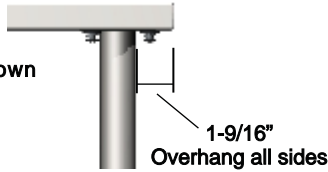

Width	24" Overall Depth With Work Top		30" Overall Depth With Work Top	
	Sitting Hgt.	Standing Hgt.	Sitting Hgt.	Standing Hgt.
24"	STA1024	STA2024	STA3024	STA4024
36"	STA1036	STA2036	STA3036	STA4036
48"	STA1048	STA2048	STA3048	STA4048
60"	STA1060	STA2060	STA3060	STA4060
72"	STA1072	STA2072	STA3072	STA4072
96"	STA1096	STA2096	STA3096	STA4096

- Tables are 16 gauge, type 304 stainless steel work top, with a #4 finish.
- Tables have adjustable bottom shelf, cast aluminum corner brackets, and 1-5/8" stainless steel tubular adjustable bullet legs.
- Overall depth with work top is 24" or 30".
- Rated to hold 600 lbs evenly distributed.
- Tables 72" and larger are equipped with six legs.
- Shipped partially assembled.

**Heavy Duty "O" Frame Tables**

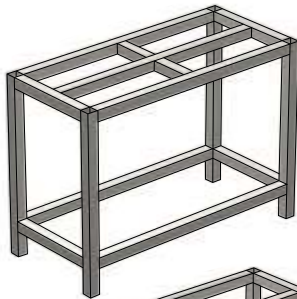

48" wide table

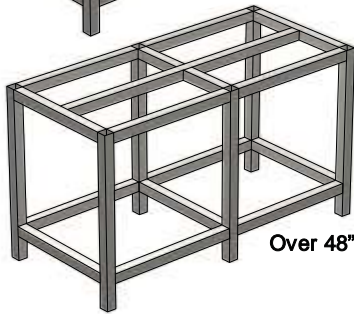

Over 48" wide tables

Width	22" Deep		28" Deep	
	Sitting Hgt.	Standing Hgt.	Sitting Hgt.	Standing Hgt.
24"	TDC2124	TDC1124	TDC2224	TDC1224
30"	TDC2130	TDC1130	TDC2230	TDC1230
36"	TDC2136	TDC1136	TDC2236	TDC1236
42"	TDC2142	TDC1142	TDC2242	TDC1242
48"	TDC2148	TDC1148	TDC2248	TDC1248
60"	TDC2160	TDC1160	TDC2260	TDC1260
72"	TDC2172	TDC1172	TDC2272	TDC1272
96"	TDC2196	TDC1196	TDC2296	TDC1296
1000mm	TDC210B	TDC110B	TDC220B	TDC120B
1500mm	TDC210C	TDC110C	TDC220C	TDC120C

- All legs and framing are 2" x 2" 14 gauge square steel tubing.
- Frame, cross-bracing and legs are welded in place. Tables larger than 48" wide are manufactured with six legs. Table legs are supplied with leveling glides.
- Tables are available in sitting height (28 3/4") and standing height (34 3/4").
- Table legs are supplied with leveling bolts and PVC boots.
- All tables will support an 1800 lb load.
- If adding casters load rating is reduced to 800lbs for 48" wide tables and 1200lbs for over 48" wide tables.
- Counter top not included.

**All-Welded Table Frame**



Width	22" Deep	28" Deep
48"	TDA2148	TDA2248
60"	TDA2160	TDA2260
72"	TDA2172	TDA2272

- Available in powder coated steel finish or stainless steel.
- Table frame is an all-welded construction, capable to support evenly distributed 800lbs load. 2" square tubular legs with leveling feet. Table frame is height adjustable in 1" increments from 28-3/4" to 34-3/4" (work surface not included).
- Table frame complete with hanging rails to suspend lower cabinets.
- To order suspended base cabinets, mobile cabinets, pencil drawers and pull out writing tablets refer to the catalog section.
- Standard depth hanging cabinets are not suitable for 22" deep tables.
- Shipped assembled.



*STEEL TABLES  
TABLES 22" DEEP*

**Standard "H" Frame Table**

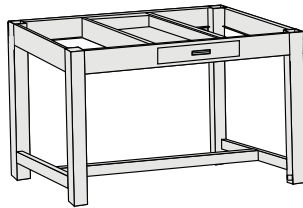
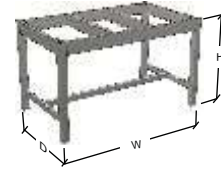

Width	Without Drawers		With Drawers		
	Sitting Hgt.	Standing Hgt.	# Drwrs	Sitting Hgt.	Standing Hgt.
24"	TAC2124	TAC1124	1	TAA2124	TAA1124
30"	TAC2130	TAC1130	1	TAA2130	TAA1130
36"	TAC2136	TAC1136	1	TAA2136	TAA1136
42"	TAC2142	TAC1142	1	TAA2142	TAA1142
48"	TAC2148	TAC1148	2	TAB2148	TAB1148
60"	TAC2160	TAC1160	2	TAB2160	TAB1160
72"	TAC2172	TAC1172	2	TAB2172	TAB1172
1000mm	TAC210B	TAC110B	1	TAA210B	TAA110B
1500mm	TAC210C	TAC110C	2	TAB210C	TAB110C

- When ordering a table with drawers to match Architectural Overlay design use option code "OL".

**Six Leg Combination Table**

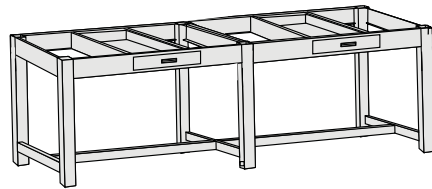

Width	Without Drawers		With Drawers		
	Sitting Hgt.	Standing Hgt.	# Drwrs	Sitting Hgt.	Standing Hgt.
72"	TCC2172	TCC1172	2	TCB2172	TCB1172
84"	TCC2184	TCC1184	2	TCB2184	TCB1184
96"	TCC2196	TCC1196	4	TCB2196	TCB1196
2000mm	TCC210D	TCC110D	2	TCB210D	TCB110D

- When ordering a table with drawers to match Architectural Overlay design use option code "OL".

*TABLES 28" DEEP*

**Standard "H" Frame Table**

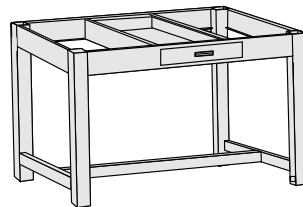

Width	Without Drawers		With Drawers		
	Sitting Hgt.	Standing Hgt.	# Drwrs	Sitting Hgt.	Standing Hgt.
24"	TAC2224	TAC1224	1	TAA2224	TAA1224
30"	TAC2230	TAC1230	1	TAA2230	TAA1230
36"	TAC2236	TAC1236	1	TAA2236	TAA1236
42"	TAC2242	TAC1242	1	TAA2242	TAA1242
48"	TAC2248	TAC1248	2	TAB2248	TAB1248
60"	TAC2260	TAC1260	2	TAB2260	TAB1260
72"	TAC2272	TAC1272	2	TAB2272	TAB1272
1000mm	TAC220B	TAC120B	1	TAA220B	TAA120B
1500mm	TAC220C	TAC120C	2	TAB220C	TAB120C

- When ordering a table with drawers to match Architectural Overlay design use option code "OL".

**Six Leg Combination Table**

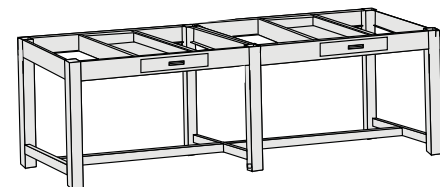

Width	Without Drawers		With Drawers		
	Sitting Hgt.	Standing Hgt.	# Drwrs	Sitting Hgt.	Standing Hgt.
72"	TCC2272	TCC1272	2	TCB2272	TCB1272
84"	TCC2284	TCC1284	2	TCB2284	TCB1284
96"	TCC2296	TCC1296	4	TCE2296	TCE1296
2000mm	TCC220D	TCC120D	2	TCE220D	TCE120D

- When ordering a table with drawers to match Architectural Overlay design use option code "OL".



*STEEL TABLES  
TABLE OPTIONS*

**Ordering Special Features**

<u>Table Options</u>	<u>Description</u>
06	One fixed shelf on "O" frame
48	Keyboard tray ( <i>Replaces drawer</i> )
49	Stainless steel adjustable height legs. Legs are adjustable in 1" increments, from 28-3/4" high to 34-3/4" high. ( <i>see note</i> )
87	Mobile table complete with casters
88	Mobile table complete with customer specified casters - <i>see note</i>
91	No lower frame ( <i>see notes</i> )
92	"U" frame style table with rear & side supports
93	Left side leg table - <i>no supports</i>
94	Right side leg table - <i>no supports</i>
95	Front table legs - <i>no supports</i>
WA	Welded Table Assembly ( <i>see note 17 in "Options" section, page A17</i> )
HU	"U" frame table with floating rail to hang cabinets for TAC tables ( <i>see note</i> )
OL	Architectural Overlay design ( <i>see note</i> )

- Tables shipped unassembled.
- All tables and sizes are supplied with lower H frames unless otherwise specified. All legs are 2"x2"x16ga steel tubing. All lower frames are 1"x2" x 16ga steel tubing. All legs are bolted in place.
- Table legs are supplied with leveling bolts and PVC boots.
- Tables are available in sitting height (28-3/4") and standing height (34-3/4").
- All tables are supplied with a lower H or U frame, and will support a 600lb load evenly distributed.
- Tables may be supplied without a lower H or U frame if the table width is 48" or less, and/or the required load is 200lbs or less. All tables may be supplied without a lower H or U frame and support a 600lb load if all legs are bolted securely to the floor. (ie: seismic design).
- Standard apron height is 3-3/4" high. If HU option is added apron is 3" high.
- Drawer width is 15" wide unless otherwise specified.
- Mobile tables of all sizes are supplied with a lower H frame, excluding mobile tables that accommodate hanging cabinets. A mobile table manufactured to accommodate hanging cabinets is specified with both options -87 (*Mobile table complete with casters*) and -HU (*U frame table with floating rail to hang cabinets*).
- 22" deep tables will only accommodate 18" deep hanging cabinets. 28" deep tables will accommodate 18" or 22" deep hanging cabinets. All tables manufactured to accommodate hanging cabinets have a lower U frame. All tables 72" and wider that are manufactured to accommodate hanging cabinets have heavy duty upper aprons.
- Option -49, shall be used only with sitting height tables, legs are adjustable in 1" increments, from 28-3/4" high to 34-3/4" high (*worktop not included*).
- Option -HU is not feasible in tables with drawers.
- Option codes 06 (*Table Shelf*) and HU (*U frame table with floating rail to hang cabinets*) for TAC tables cannot be used together.
- When ordering a table with drawers to match Architectural Overlay design use option code "OL".
- Provide complete specification and source for all special option ordered.

*STEEL TABLES*

*22" AND 28" DEEP STEEL TABLES FOR SUSPENDING CABINETS*

**Mobile "U" Frame Tables**



22" Deep		
Width	28-3/4" High	34-3/4" High
36"	TAC2136 Opt-87-HU	TAC1136 Opt-87-HU
42"	TAC2142 Opt-87-HU	TAC1142 Opt-87-HU
48"	TAC2148 Opt-87-HU	TAC1148 Opt-87-HU
60"	TAC2160 Opt-87-HU	TAC1160 Opt-87-HU
72"	TAC2172 Opt-87-HU	TAC1172 Opt-87-HU

28" Deep		
Width	28-3/4" High	34-3/4" High
36"	TAC2236 Opt-87-HU	TAC1236 Opt-87-HU
42"	TAC2242 Opt-87-HU	TAC1242 Opt-87-HU
48"	TAC2248 Opt-87-HU	TAC1248 Opt-87-HU
60"	TAC2260 Opt-87-HU	TAC1260 Opt-87-HU
72"	TAC2272 Opt-87-HU	TAC1272 Opt-87-HU

- 22" deep tables will only accommodate 18" deep hanging cabinets.
- 28" deep tables will accommodate 18" or 22" deep hanging cabinets.
- Tables with option code HU are manufactured with a 3" high heavy duty apron.
- Remove option code HU to order an "H" frame table that does not need to suspend hanging cabinets.
- Glass reinforced nylon total lock swivel caster with non-marking rubber wheels.
- Add option code 49 to order adjustable height legs. Legs are adjustable in 1" increments, from 28-3/4" high to 34-3/4" high.
- Worktop not included.

**Six Leg Mobile "U" Frames**



22" Deep		
Width	28-3/4" High	34-3/4" High
72"	TCC2172 Opt-87-HU	TCC1172 Opt-87-HU
84"	TCC2184 Opt-87-HU	TCC1184 Opt-87-HU
96"	TCC2196 Opt-87-HU	TCC1196 Opt-87-HU

28" Deep		
Width	28-3/4" High	34-3/4" High
72"	TCC2272 Opt-87-HU	TCC1272 Opt-87-HU
84"	TCC2284 Opt-87-HU	TCC1284 Opt-87-HU
96"	TCC2296 Opt-87-HU	TCC1296 Opt-87-HU

- 22" deep tables will only accommodate 18" deep hanging cabinets.
- 28" deep tables will accommodate 18" or 22" deep hanging cabinets.
- Tables with option code HU are manufactured with a 3" high heavy duty apron.
- Remove option code HU to order an "H" frame table that does not need to suspend hanging cabinets.
- Glass reinforced nylon total lock swivel caster with non-marking rubber wheels.
- Add option code 49 to order adjustable height legs. Legs are adjustable in 1" increments, from 28-3/4" high to 34-3/4" high.
- Worktop not included.

*STEEL TABLES*  
*TABLES*

**Crank-Operated Table Frames**

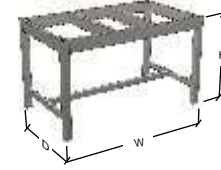

Note: 23" Deep table shown.

Table Frame Width	Adjustable From 25"-33" (8" of travel)		Adjustable From 29"-41" (12" of travel)	
	23" Deep	29" Deep	23" Deep	29" Deep
36"	ACT2036	ACT2136	ACT1036	ACT1136
48"	ACT2048	ACT2148	ACT1048	ACT1148
60"	ACT2060	ACT2160	ACT1060	ACT1160

- Tables are not suitable for hanging cabinets.
- Table complete with integral modesty panel and table legs are supplied with leveling glides.
- Crank-operated height adjustability from 25" to 33" or 29" to 41" .
- All tables will support a 300 lb load.
- Table frame only, work surface not included.



Table Frame Width	Adjustable from 28-3/4" to 34-3/4" 28" Deep
36"	ACC2136
48"	ACC2148
60"	ACC2160
72"	ACC2172

- Table legs are 2" X 2", 16 gauge square steel tubing.
- Crank-operated height adjustability from 28-3/4" to 39-3/4".
- Legs are supplied with leveling glides.
- All tables will support a 750 lb load.
- Table frame only, work surface not included.

**Adjustable Height Science Tables**



Work Surface Size	Item Number
48" x 36"	SCT0148
60" x 36"	SCT0160
72" x 36"	SCT0172
96" x 36"	SCT0196

- Hand crank height adjustment from 30" to 40" allows multiple uses.
- Dimensions may be adjusted to suit customer requirements.
- Load bearing capacity of 500lbs (including work surface).
- Work surface not included.
- The unit comes with 3 electrical cutouts and cover plates.
- If you require receptacles/wiring please contact Mott for pricing.
- Available Options:
  - EM (Integral Electric for height adjustment.
  - CD (Provision for height adjustment by Cordless Power Drill)
  - CU (CPU holder below work surface of table)
  - BH (Hooks for book bags below work surface)

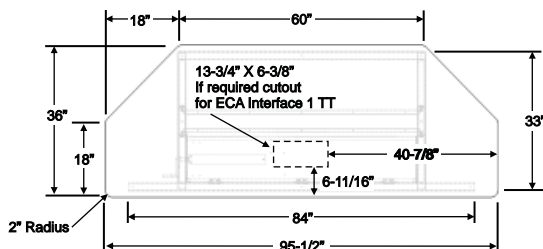

**Typical Adjustable Height Science Table Work Surface**

- Recommended work surface is as shown - notched to allow multiple tables to fit together.
- Drawing shown for 96" wide unit.

*STEEL TABLES*  
*TABLES*

**Vibration Isolation Tables**



Width	22" Deep		28" Deep	
	Sitting Hgt.	Standing Hgt.	Sitting Hgt.	Standing Hgt.
36"	VIT2136	VIT1136	VIT2236	VIT1236
42"	VIT2142	VIT1142	VIT2242	VIT1242
48"	VIT2148	VIT1148	VIT2248	VIT1248

The Vibration Isolation Table is designed to provide stable working conditions for devices that are sensitive to vibration and shocks. Table consists of an outer table frame that supports the main work surface which is not isolated from vibration and an inner table frame that is entirely separate and supports the inner isolated work surface. This ensures vibrations are not transmitted to the isolated inner work surface.

- **Outer Table Frame** consists of two 18 gauge hollow vertical pedestals. Each pedestal has removable inner panels for access the anchor bolts and levelers. Pedestals are connected with 16 gauge steel rails. A flange is provided around the perimeter of the pedestals for mounting of the non-isolated work surface.
- **Inner Table Frame** consists of a rectangular hollow steel welded frame with each leg supplied with levelers and provisions for anchoring. Legs are joined by 11 gauge steel angles which support the isolated platform.
- **Isolated Platform** consists of a formed 18 gauge steel tray that is to be filled with ballast (such as sand or concrete - not included). The platform is supported by four rubber shock absorbing isolators. A flange is provided around the perimeter of the tray for mounting the isolated work surface.
- Available in either type 304 stainless steel or powder coated steel.
- Work surface not included.
- Ships assembled.

Top of Table View

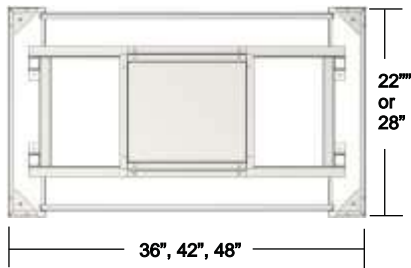

Front View

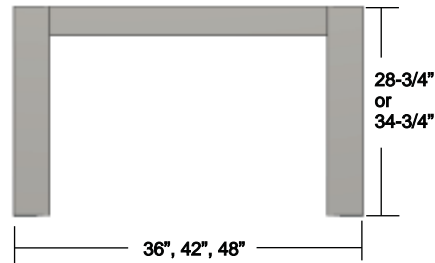

Typical Non-Isolated 1" Thick Work Surface For 22" and 28" Deep Tables

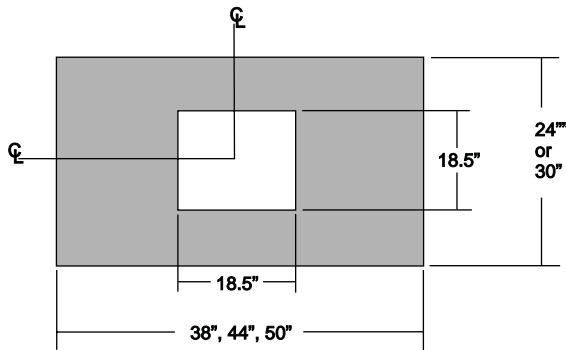

Typical Inner Isolated 1" Thick Work Surface For 22" and 28" Deep Tables

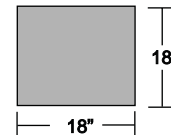

- Work surface shown with 1" overhang on all sides for freestanding installations.
- When in an elevation of casework, adjust overhang as needed.

*STEEL TABLES*  
*STEEL TABLES COMPONENTS*

**Pencil Drawers**



Width	Item Number
15"	PEN0015
18"	PEN0018
20"	PEN0020
24"	PEN0024
30"	PEN0030

- Pencil Drawer suspends from tables with hanging rails.
- Drawer on Pencil Drawer is supplied with full extension runners.
- When ordering a table with aprons add option code HU to suspend Pencil Drawer.

**Pull Out Writing Tablet**



Width	Item Number
15"	PUL0015
18"	PUL0018
20"	PUL0020
24"	PUL0024
30"	PUL0030

- Pull Out Writing Tablet suspends from tables with hanging rails.
- Pull Out Writing Tablet is supplied with full extension runners.
- When ordering a table with aprons add option code HU to suspend Pull Out Writing Tablet.

**Hanging CPU Holder**

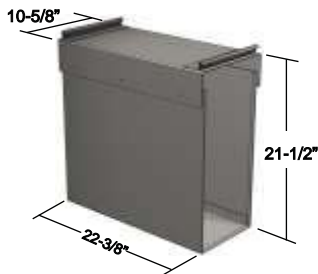

Item Number
CPU1010

- Suspends from tables with hanging rails and is supplied with full extension runners to slide out CPU unit.
- Inside clear dimension of CPU holder is 9-3/16".
- Hanging CPU Holder does not fit on a 22" deep table.
- When ordering a table with aprons add option code HU to suspend CPU holder.

*WOOD TABLES  
TABLES 22" DEEP*

**Standard "H" Frame Tables**

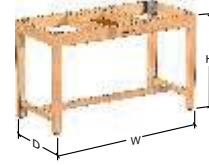

Width	Without Drawers		With Drawers		
	Sitting Hgt.	Standing Hgt.	Standing Hgt.	Sitting Hgt.	# Drwrs
24"	TAC2124W	TAC1124W	TAA1124W	TAA2124W	1
30"	TAC2130W	TAC1130W	TAA1130W	TAA2130W	1
36"	TAC2136W	TAC1136W	TAA1136W	TAA2136W	1
42"	TAC2142W	TAC1142W	TAA1142W	TAA2142W	1
48"	TAC2148W	TAC1148W	TAB1148W	TAB2148W	2
60"	TAC2160W	TAC1160W	TAB1160W	TAB2160W	2
72"	TAC2172W	TAC1172W	TAB1172W	TAB2172W	2
1000mm	TAC210BW	TAC110BW	TAA110BW	TAA210BW	1
1500mm	TAC210CW	TAC110CW	TAB110CW	TAB210CW	2

**Six Leg Combination Tables**



Width	Without Drawers		With Drawers		
	Standing Hgt.	Sitting Hgt.	Standing Hgt.	Sitting Hgt.	# Drwrs
72"	TCC1172W	TCC2172W	TCB1172W	TCB2172W	2
84"	TCC1184W	TCC2184W	TCB1184W	TCB2184W	2
96"	TCC1196W	TCC2196W	TCB1196W	TCB2196W	4
2000mm	TCC110DW	TCC210DW	TCB110DW	TCB210DW	2

*TABLES 28" DEEP*

**Standard "H" Frame Tables**



Width	Without Drawers		With Drawers		
	Sitting Hgt.	Standing Hgt.	Standing Hgt.	Sitting Hgt.	# Drwrs
24"	TAC2224W	TAC1224W	TAA1224W	TAA2224W	1
30"	TAC2230W	TAC1230W	TAA1230W	TAA2230W	1
36"	TAC2236W	TAC1236W	TAA1236W	TAA2236W	1
42"	TAC2242W	TAC1242W	TAA1242W	TAA2242W	1
48"	TAC2248W	TAC1248W	TAB1248W	TAB2248W	2
60"	TAC2260W	TAC1260W	TAB1260W	TAB2260W	2
72"	TAC2272W	TAC1272W	TAB1272W	TAB2272W	2
1000mm	TAC220BW	TAC120BW	TAA120BW	TAA220BW	1
1500mm	TAC220CW	TAC120CW	TAB120CW	TAB220CW	2

**Six Leg Combination Tables**



Width	Without Drawers		With Drawers		
	Sitting Hgt.	Standing Hgt.	Standing Hgt.	Sitting Hgt.	# Drwrs
72"	TCC2272W	TCC1272W	TCB1272W	TCB2272W	2
84"	TCC2284W	TCC1284W	TCB1284W	TCB2284W	2
96"	TCC2296W	TCC1296W	TCE1296W	TCE2296W	4
2000mm	TCC220DW	TCC120DW	TCE120DW	TCE220DW	2

*WOOD TABLES  
TABLE OPTIONS*

**Ordering Special Features**

<u>Table Options</u>	<u>Description</u>
06	One fixed shelf on "O" frame tables
48	Keyboard tray (replaces drawer)
49	Stainless steel adjustable height inserts. Legs are adjustable in 1" increments, from 28-3/4" high to 34-3/4" high.
87	Mobile table complete with casters
88	Mobile table complete with customer specified casters
91	Table with no supports
92	"U" frame style table with rear & side supports
93	Left side leg table - no supports
94	Right side leg table - no supports
95	Front table legs - no supports

- Tables shipped unassembled.
- All tables and sizes are supplied with lower H frames unless otherwise specified. All legs are bolted in place.
- Table legs are supplied with leveling bolts and PVC boots.
- Tables are available in sitting height (28-3/4") and standing height (34-3/4").
- All tables are supplied with a lower H or U frame.
- Tables may be supplied without a lower H or U frame if the table width is 48" or less, and/or the required load is 200lbs or less. All tables may be supplied without a lower H or U frame and support a 600lb load if all legs are bolted securely to the floor. (ie: seismic design).
- Standard apron height is 3-3/4" high.
- Drawer width is 15" wide unless otherwise specified.
- Mobile tables of all sizes are supplied with a lower H frame.
- Option -49, shall be used only with sitting height tables, legs are adjustable in 1" increments, from 28-3/4" high to 34-3/4" high.
- Provide complete specification and source for all special option ordered.



*SIGMA FLEX™*

*ADAPTABLE LABORATORY FURNITURE SOLUTIONS*

**The Sigma Flex™ System**

Designed for the Lab of Tomorrow...

Laboratory technology changes today at an ever increasing rate. Today's challenge is to create an ideal workplace that has the potential to deliver future adaptability. Mott's Sigma Flex™ systems furniture successfully meets this challenge by delivering high levels of architectural style and reconfiguration potential, not only for today's lab, but also tomorrow's.

Mott's Sigma Flex™ system incorporates a standard core assembly from which upper and lower storage components and work surfaces are cantilevered. Further adaptability allows this system to be configured as an island assembly or a wall core assembly.

An extensive range of reconfiguration possibilities are available, allowing the laboratory designer to maximize laboratory productivity and space utilization through this stylish and ergonomically sound investment.

Mott's industry-leading flexible design and manufacturing capabilities allow the already very adaptable Sigma Flex™ system to be further modified to meet each laboratory's unique requirements through the incorporation of custom features.

What's more, Mott's Sigma Flex™ system is a proven practical solution. It can be installed and reconfigured with minimal down time, through the use of basic skills and without special tools.

**For additional information and help in planning contact Mott Manufacturing.**

*SIGMA FLEX™*

*ADAPTABLE LABORATORY FURNITURE SOLUTIONS*

**Modular Support Structure Design**

Each core system is fabricated from prime quality furniture grade cold rolled steel.

Support systems are a core and panel style support structure.

Core structures can be supported by anchoring to suitable flooring material or may be supported by structural table legs (outrigger legs).

Modular components are suitable for single faced wall core or double faced peninsula or island configurations.

Core assemblies have removable panels on all sides.

**Modular Support Structure Features**

Core or wall systems support work surfaces, under counter cabinets and overhead storage components.

Structural core systems may be configured for floor anchor alone, or additional support legs may be used if floor is not of sufficient strength for cantilever support.

The core system allows plumbing, electrical and other services to be installed using commonly available mounting systems.

Suspended cabinets can be supported using hook shaped rails attached near the front and rear of the cantilevered work surface. Cabinets can be added at any time and it is possible to remove and relocate a fully loaded cabinet to any position between legs.

All access panels can be fastened with a positive friction catch which snaps into place. The panel does not require adhesives to be attached. Panels are half width and it is possible to remove panels without removing suspended cabinets.

Upper storage cabinets are adjustable vertically and laterally and are removable.

Suspended cabinets can be relocated without disturbing the countertop.

The vertical height of table work surfaces, upper storage units and shelves can be adjusted in 1" increments without the use of special tools.

**Material Gauges**

- Riser Uprights 16 gauge galvanized
- Upright connecting members 16 gauge
- Base cover 18 gauge
- Riser caps PVC, ABS or CRS
- Closure panels 18 gauge
- Floor Anchor Brackets 3" x 2" x 1/4" thick

*SIGMA FLEX™*  
*12" DEEP ISLAND CORES*

**Island Cores**

Island Cores provide support for cantilevered upper and lower storage components and work surfaces and can accommodate major services. Island cores are 12" deep and offered in various widths and are available as lower or full height assemblies. Raised core assemblies are also available as lower or full height island cores.

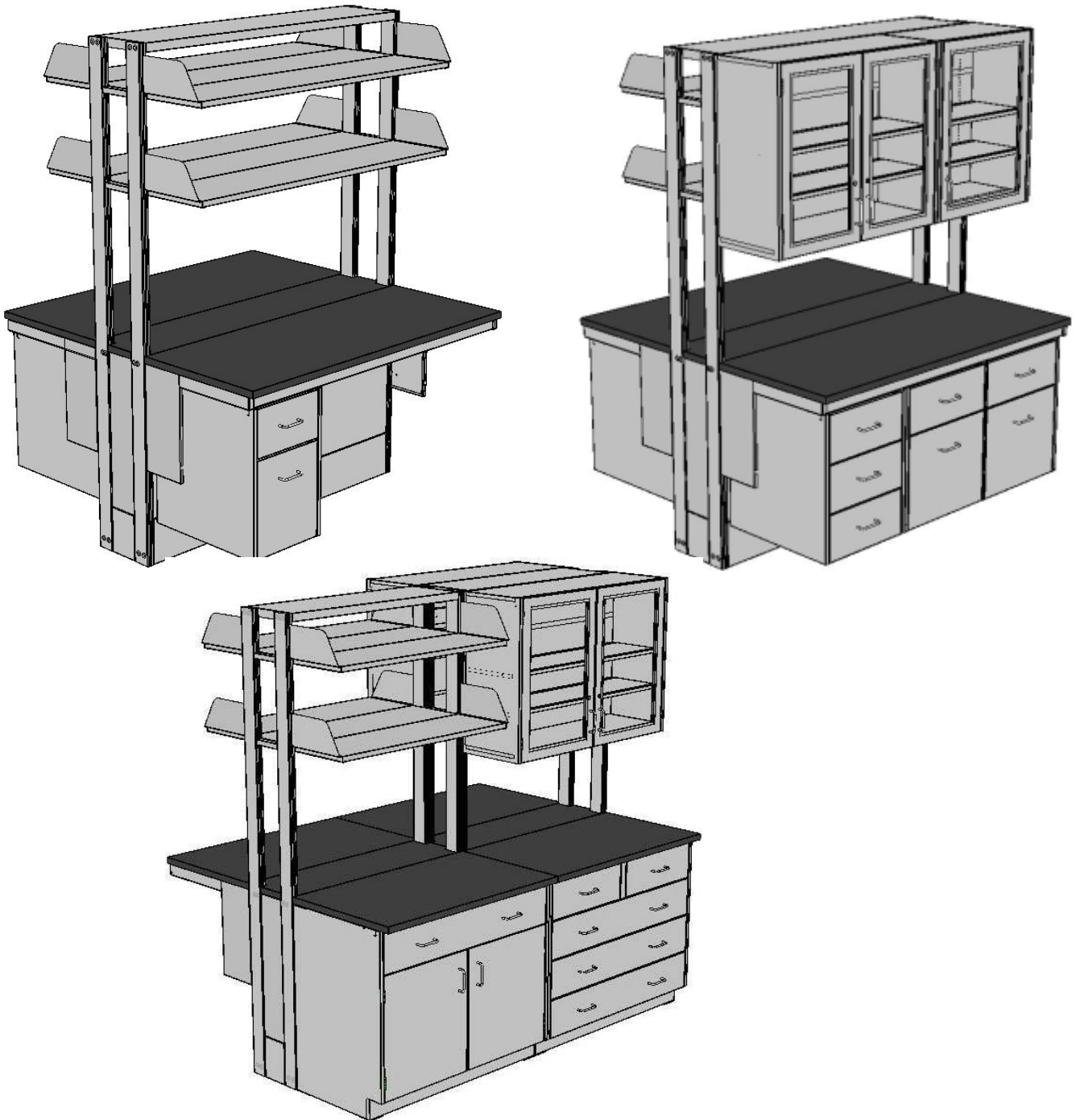

*SIGMA FLEX™*  
*12" DEEP ISLAND CORES*

**Parts List**

- 1) Flex Island Core - Lower Frame End
- 2) Flex Island Core - Insert Panel
- 3) Left Hand Flex Post (Galvanized and Painted), Complete with Leveler
- 4) Right Hand Flex Post (Galvanized and Painted), Complete with Leveler
- 5) Flex Island Top Fixed Shelf
- 6) Flex Island Upright Frame (Galvanized)  
Note: Lower Core Assembly is complete with one frame only. Raised Core Assembly complete with two frames (as shown).
- 7) Flex Island Upright - Lower End Filler
- 8) Flex Island Upright - Raised Core End Filler
- 9) Flex Bottom Filler
- 10) Flex Joining Plate (Galvanized)
- 11) Flex Core Base Angle
- 12) Flex Island Core - Raised Insert Panel  
Note: Only On Raised Core Assembly
- 13) Internal Core Side Brace

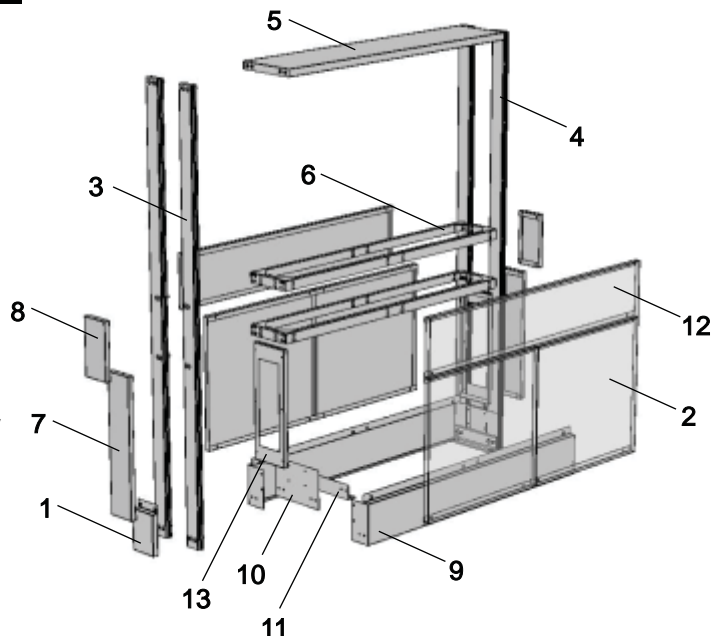

**Load Ratings**

**Load Maximums**

Maximum load ratings are live loads and include loads applied to top of work surface, including total weight of shelves and suspended cabinetry and other accessories. These capacities should be used as guidelines only. Please contact Mott Manufacturing for specific load requirements. Maximum load ratings are based on the load being evenly balanced on both sides. Individual component or assembly load ratings should not be exceeded for any surface.

**Maximum Load Ratings**

**Modular Support Structure**

- Top of Core 180lbs
- Top of Reagent Rack 180lbs
- Cantilevered Work surface 600lbs

**Shelving**

- 8" deep 180lbs
- 12" deep 180lbs
- 18" deep 130lbs
- 24" deep 100lbs

**Suspended Cabinets**

- Base Cabinets 300lbs
- Upper Cabinets 300lbs

**Total Island Core Assembly**

- Island Core 2820lbs

Includes two work surfaces at 600lbs each, and any combination of shelves, suspended upper cabinets (at their rated loads). Loads must be balanced both sides.

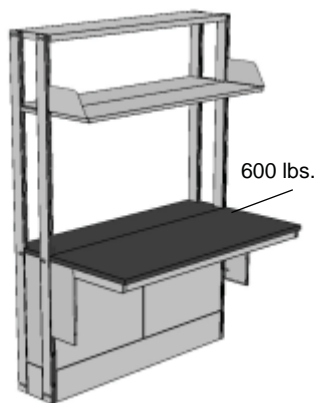

Island Core with Cantilever Table One Side

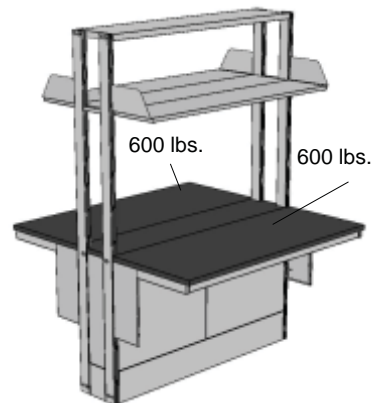

Island Core with Cantilever Table Double Sided

*SIGMA FLEX™*  
*12" DEEP ISLAND CORE ASSEMBLIES*

**Lower Island Cores**

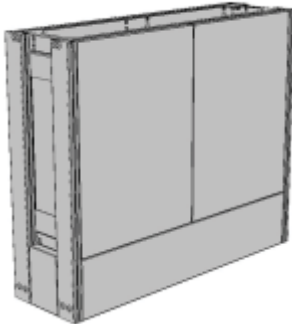

Width	Item Number
24"	FLS2024
30"	FLS2030
36"	FLS2036
42"	FLS2042
48"	FLS2048
54"	FLS2054
60"	FLS2060
66"	FLS2066
72"	FLS2072

- Core is 34-3/4" high and includes insert panels.
- Structure allows for plumbing, electrical and other services to be installed.
- Inserts are easy to remove, allowing for quick access to services.
- Simple to attach to adjacent cores.

**Lower Island Raised Cores**

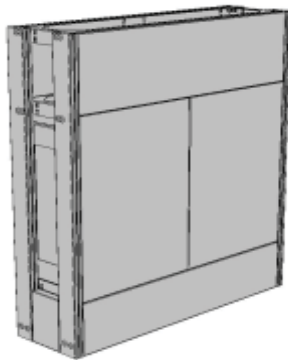

With Insert Panels

Width	With Insert Panels	Without Insert Panels
24"	FLS4024	FLS4124
30"	FLS4030	FLS4130
36"	FLS4036	FLS4136
42"	FLS4042	FLS4142
48"	FLS4048	FLS4148
54"	FLS4054	FLS4154
60"	FLS4060	FLS4160
66"	FLS4066	FLS4166
72"	FLS4072	FLS4172

- Core is 45-3/4" high.
- Structure allows for plumbing, electrical and other services to be installed.
- Optional insert panels are easy to remove, allowing for quick access to services.
- Simple to attach to adjacent cores.

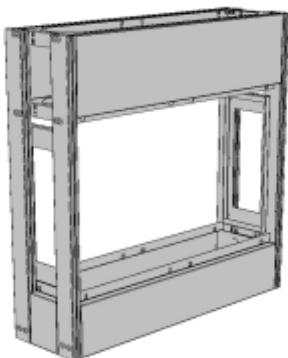

Without Insert Panels

*SIGMA FLEX™*  
*12" DEEP ISLAND CORE ASSEMBLIES*

**Full Height Island Cores**

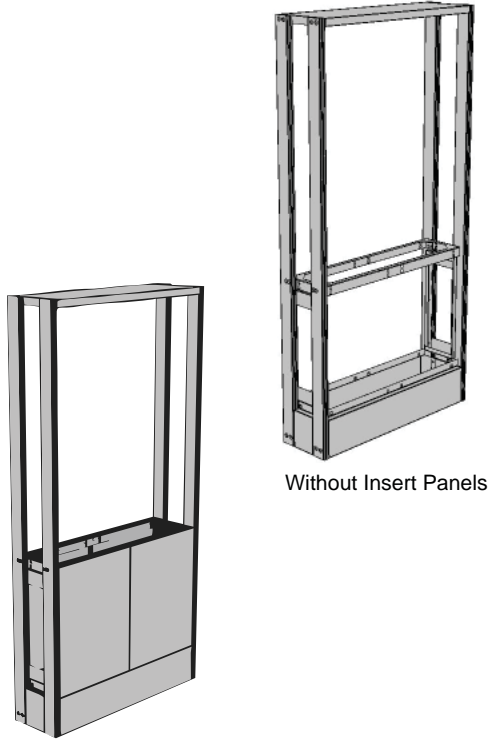

Without Insert Panels

With Insert Panels

Width	With Insert Panels	Without Insert Panels
24"	FLS1024	FLS1124
30"	FLS1030	FLS1130
36"	FLS1036	FLS1136
42"	FLS1042	FLS1142
48"	FLS1048	FLS1148
54"	FLS1054	FLS1154
60"	FLS1060	FLS1160
66"	FLS1066	FLS1166
72"	FLS1072	FLS1172

- One Piece Full Height assembly is 85" high and includes upper and lower island core.
- Lower core height is 34-3/4" high.
- Structure allows for plumbing, electrical and other services to be installed.
- Optional insert panels are easy to remove, allowing for quick access to services.
- Simple to attach to adjacent cores.

**Full Height Island Raised Cores**

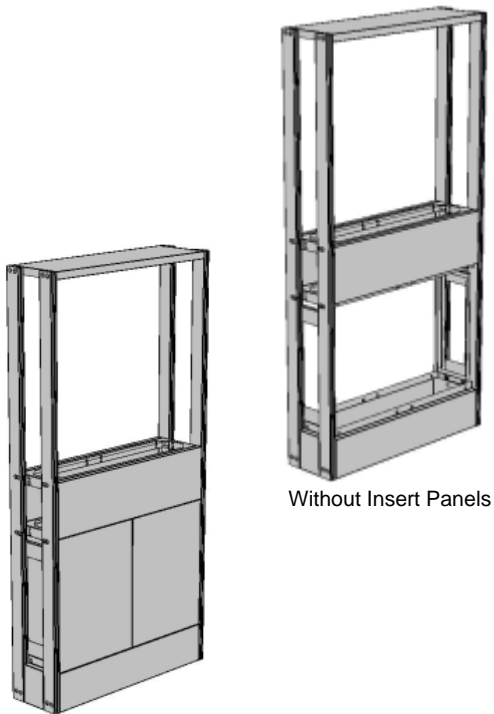

Without Insert Panels

With Insert Panels

Width	With Insert Panels	Without Insert Panels
24"	FLS3024	FLS3124
30"	FLS3030	FLS3130
36"	FLS3036	FLS3136
42"	FLS3042	FLS3142
48"	FLS3048	FLS3148
54"	FLS3054	FLS3154
60"	FLS3060	FLS3160
66"	FLS3066	FLS3166
72"	FLS3072	FLS3172

- One Piece Full Height Raised assembly is 85" high and includes upper and lower island core.
- Lower core height is 45-3/4" high.
- Structure allows for plumbing, electrical and other services to be installed.
- Optional insert panels are easy to remove, allowing for quick access to services.



*SIGMA FLEX™*  
*8-3/4" DEEP WALL CORES*

**Wall Cores**

Wall Cores are designed for setting up around the edges of your lab by securing to the wall and floor. This provides support for cantilevered work surfaces and suspended cabinets. Wall cores are 8-3/4" deep and offered in various widths and are available as lower or full height assemblies. Raised core assemblies are also available as lower or full height wall cores.

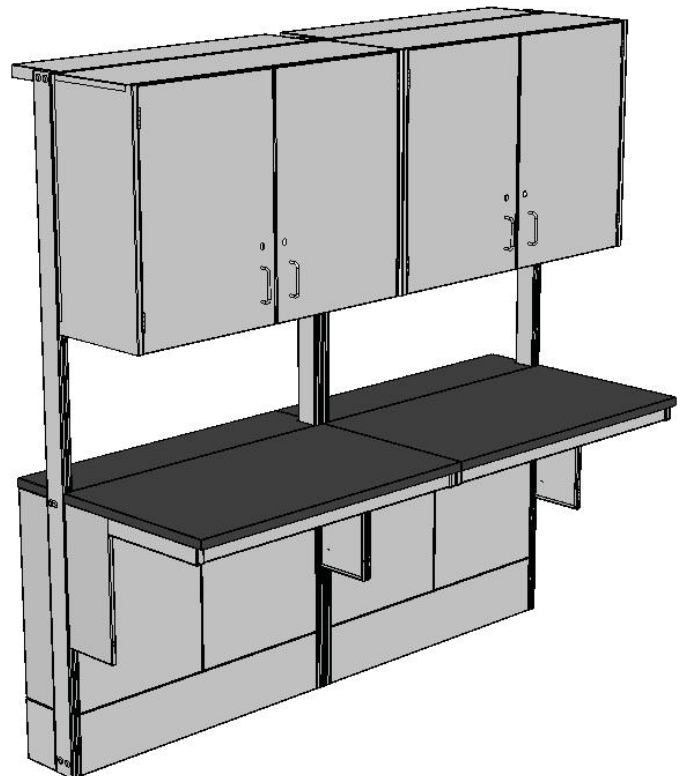
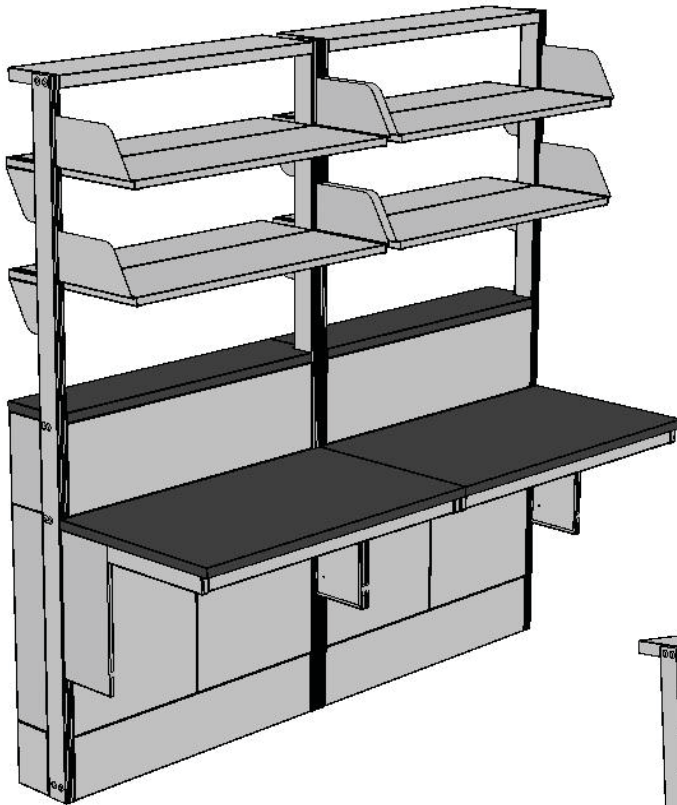



*SIGMA FLEX™*  
*8-3/4" DEEP WALL CORES*

**Parts List**

- 1) Flex Wall Core - Lower Frame End
- 2) Flex Wall Core - Insert Panel
- 3) Left Hand Flex Post (Galvanized and Painted), Complete with Leveler
- 4) Right Hand Flex Post (Galvanized and Painted), Complete with Leveler
- 5) Flex Wall Top Fixed Shelf
- 6) Flex Wall Upright Frame (Galvanized)  
Note - Lower Core Assembly is complete with one frame only. Raised Core Assembly complete with two frames (as shown).
- 7) Flex Wall Upright -Lower End Filler
- 8) Flex Wall Upright - Raised Core End Filler
- 9) Flex Bottom Filler
- 10) Flex Joining Plate (Galvanized)
- 11) Flex Core Base Angle
- 12) Flex Wall Core - Raised Insert Panel  
Note: Only On Raised Wall Core Assembly

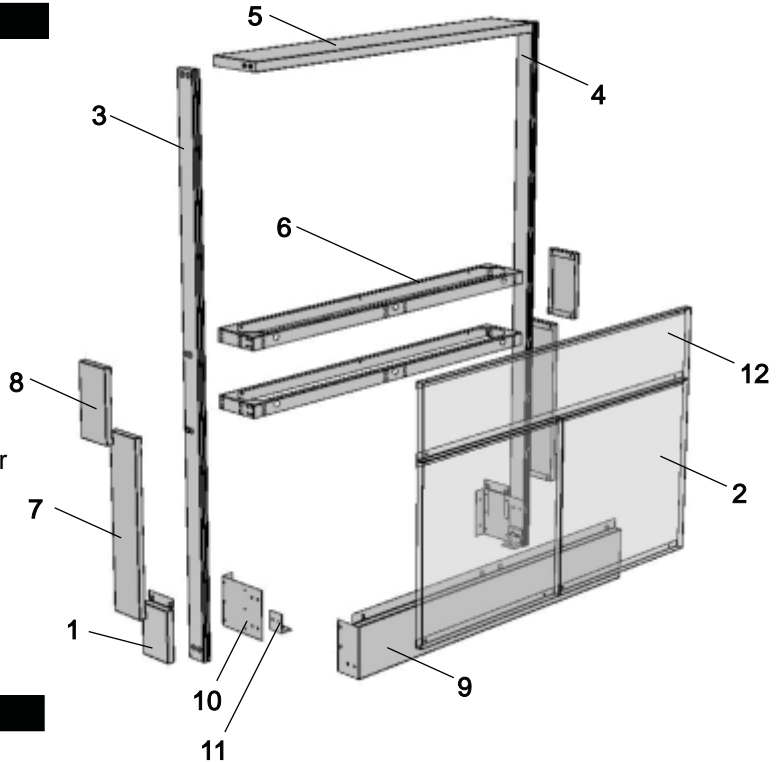

**Load Ratings**

**Load Maximums**

Maximum load ratings are live loads and include loads applied to top of work surface, including total weight of shelves and suspended cabinetry and other accessories. These capacities should be used as guidelines only. Please contact Mott Manufacturing for specific load requirements. Maximum load ratings are based on the load being evenly balanced on both sides. Individual component or assembly load ratings should not be exceeded for any surface.

**Maximum Load Ratings**

<b>Modular Support Structure</b>	
• Top of Core	180lbs
• Top of Reagent Rack	180lbs
• Cantilevered Work surface	600lbs
<b>Shelving</b>	
• 8" deep	180lbs
• 12" deep	180lbs
• 18" deep	130lbs
• 24" deep	100lbs
<b>Suspended Cabinets</b>	
• Base Cabinets	300lbs
• Upper Cabinets	300lbs

**Total Wall Core Assembly**  
• Wall Core 1680lbs  
Includes one work surface at 600lbs, and any combination of shelves, suspended upper cabinets (at their rated loads).

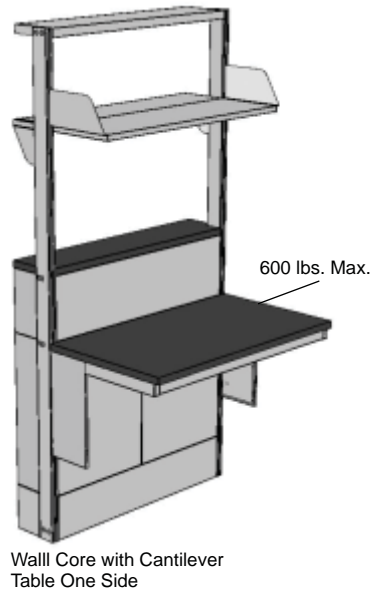

Wall Core with Cantilever Table One Side

*SIGMA FLEX™*  
*8-3/4" DEEP WALL CORE ASSEMBLIES*

**Lower Wall Cores**

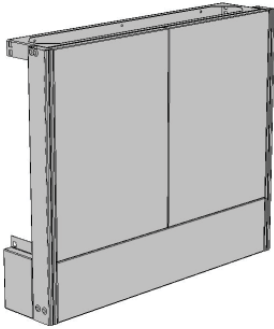

Width	Item Number
24"	FLW2024
30"	FLW2030
36"	FLW2036
42"	FLW2042
48"	FLW2048
54"	FLW2054
60"	FLW2060
66"	FLW2066
72"	FLW2072

- Core is 34-3/4" high and includes insert panels.
- Structure allows for plumbing, electrical and other services to be installed.
- Inserts are easy to remove, allowing for quick access to services.
- Simple to attach to adjacent cores.

**Lower Wall Raised Cores**

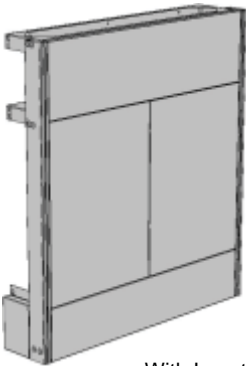

With Insert Panel

Width	With Insert Panel	Without Insert Panel
24"	FLW4024	FLW4124
30"	FLW4030	FLW4130
36"	FLW4036	FLW4136
42"	FLW4042	FLW4142
48"	FLW4048	FLW4148
54"	FLW4054	FLW4154
60"	FLW4060	FLW4160
66"	FLW4066	FLW4166
72"	FLW4072	FLW4172

- Core is 45-3/4" high.
- Structure allows for plumbing, electrical and other services to be installed.
- Optional insert panels are easy to remove, allowing for quick access to services.

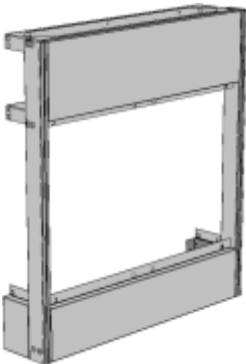

Without Insert Panel

*SIGMA FLEX™*  
*8-3/4" DEEP WALL CORE ASSEMBLIES*

**Full Height Wall Cores**

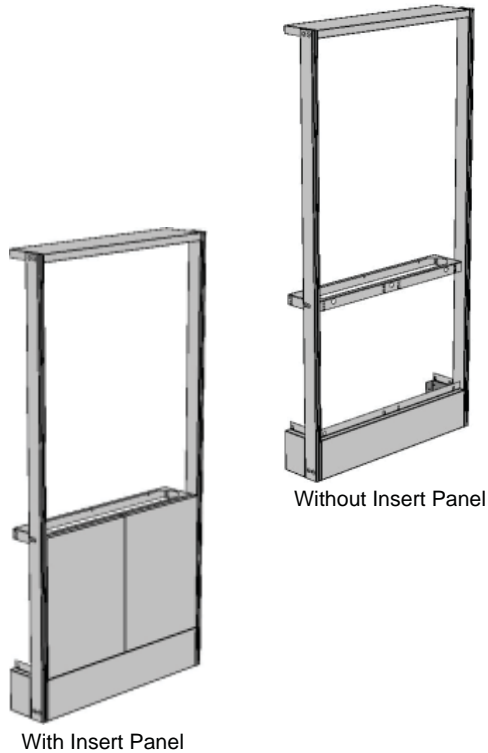

Width	With Insert Panel	Without Insert Panel
24"	FLW1024	FLW1124
30"	FLW1030	FLW1130
36"	FLW1036	FLW1136
42"	FLW1042	FLW1142
48"	FLW1048	FLW1148
54"	FLW1054	FLW1154
60"	FLW1060	FLW1160
66"	FLW1066	FLW1166
72"	FLW1072	FLW1172

- One Piece Full Height assembly is 85" high and includes upper and lower island core.
- Lower core height is 34-3/4" high.
- Structure allows for plumbing, electrical and other services to be installed.
- Optional insert panels are easy to remove, allowing for quick access to services.
- Simple to attach to adjacent cores.

**Full Height Wall Raised Cores**

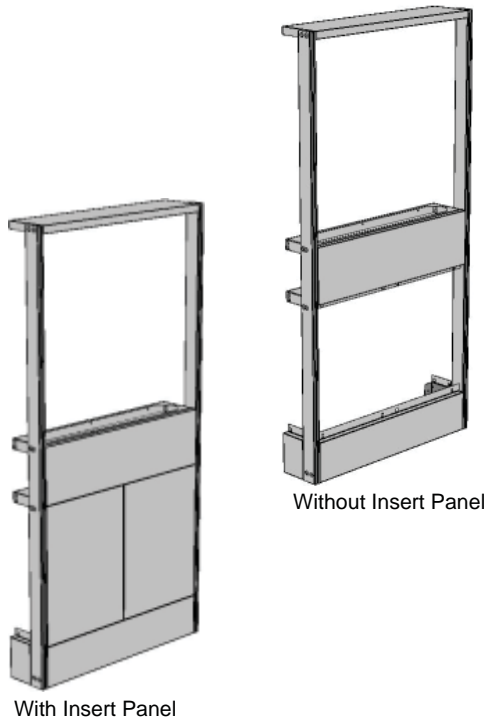

Width	With Insert Panel	Without Insert Panel
24"	FLW3024	FLW3124
30"	FLW3030	FLW3130
36"	FLW3036	FLW3136
42"	FLW3042	FLW3142
48"	FLW3048	FLW3148
54"	FLW3054	FLW3154
60"	FLW3060	FLW3160
66"	FLW3066	FLW3166
72"	FLW3072	FLW3172

- One Piece Full Height Raised assembly is 85" high and includes upper and lower island core.
- Lower core height is 45-3/4" high.
- Structure allows for plumbing, electrical and other services to be installed.
- Insert panels are easy to remove, allowing for quick access to services.
- Simple to attach to adjacent cores.

*SIGMA FLEX™*  
*6" DEEP SINGLE CORE ISLAND FRAMES*

**Single Core Frames**

Single Core Island Frames house all services, including electrical and data, plumbing and water and gases in the lower panels. They are designed to provide support for work surfaces, casework and shelves. Island Frames are 6" deep and offered in various widths and are available in full height assemblies with the option of upper frames to create a floor-to-ceiling anchorage. Consult Mott Manufacturing when using "L" shapes wider than 8' or any width of straight core that require Cantilevered Table Frames.

**Single Core - Lower Core 28-3/4" H**



With Insert Panels



Without Insert Panels

Lower Core 28-3/4" High		
Width	With Insert Panels	No Insert Panels
24"	SWF1024	SWF1124
30"	SWF1030	SWF1130
36"	SWF1036	SWF1136
48"	SWF1048	SWF1148
54"	SWF1054	SWF1154
60"	SWF1060	SWF1160
66"	SWF1066	SWF1166
72"	SWF1072	SWF1172

- One piece full height assembly is 85" high by 6" deep (Ceiling extensions can be added to enclose an area up to 120" high).
- Accepts Sigma Flex™ shelves and above counter storage, adjustable on 1" increments.
- Optional insert cover panels are easy to remove, allowing for quick access to services.

**Single Core - Lower Core 34-3/4" H**



With Insert Panels



Without Insert Panels

Lower Core 34-3/4" High		
Width	With Insert Panels	No Insert Panels
24"	SWF2024	SWF2124
30"	SWF2030	SWF2130
36"	SWF2036	SWF2136
48"	SWF2048	SWF2148
54"	SWF2054	SWF2154
60"	SWF2060	SWF2160
66"	SWF2066	SWF2166
72"	SWF2072	SWF2172

- One piece full height assembly is 85" high by 6" deep (Ceiling extensions can be added to enclose an area up to 120" high).
- Accepts Sigma Flex™ shelves and above counter storage, adjustable on 1" increments.
- Optional insert cover panels are easy to remove, allowing for quick access to services.

**Single Core - Lower Raised Core 45-3/4" H**



With Insert Panels



Without Insert Panels

Lower Core 45-3/4" High		
Width	With Insert Panels	No Insert Panels
24"	SWF3024	SWF3124
30"	SWF3030	SWF3130
36"	SWF3036	SWF3136
48"	SWF3048	SWF3148
54"	SWF3054	SWF3154
60"	SWF3060	SWF3160
66"	SWF3066	SWF3166
72"	SWF3072	SWF3172

- One piece full height assembly is 85" high by 6" deep (Ceiling extensions can be added to enclose an area up to 120" high).
- Accepts Sigma Flex™ shelves and above counter storage, adjustable on 1" increments.
- Optional insert cover panels are easy to remove, allowing for quick access to services.

*SIGMA FLEX™  
COUNTERTOP UPRIGHTS*

**Countertop Uprights**

Countertop Uprights makes the most of the work surface space. Island or wall Countertop Uprights assemblies can be mounted to any new or existing work surface and suspend shelving components (accommodates a maximum of 6 Sigma Flex™ shelves). Uprights are 49" high and are offered in island or wall mounted assemblies in various widths.

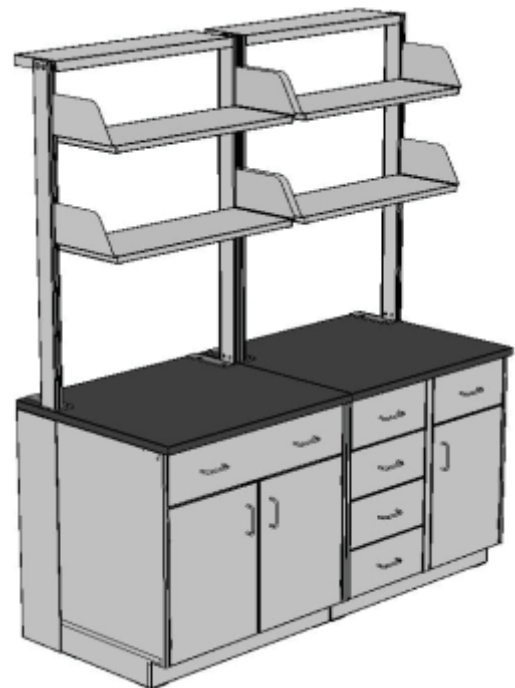
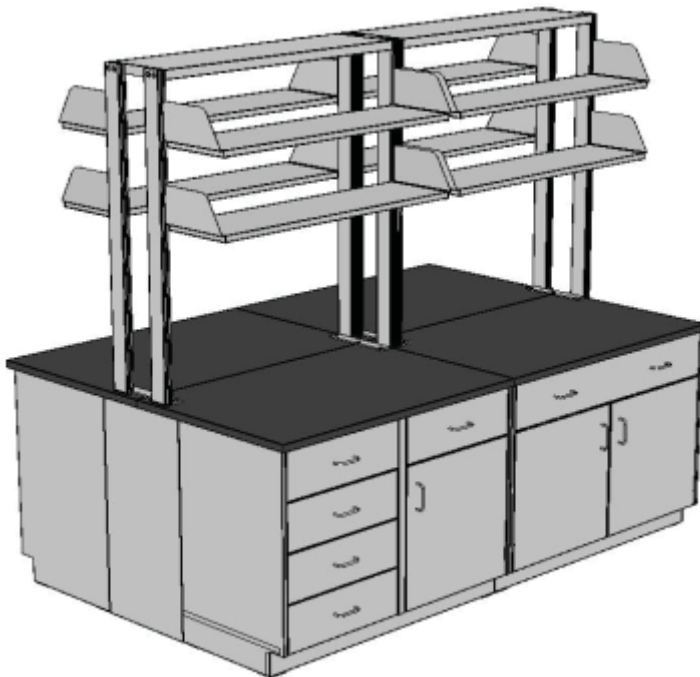

**Parts List**

- 1) Top Shelf
- 2) Flex Post with welded mounting plate



Countertop Island Upright

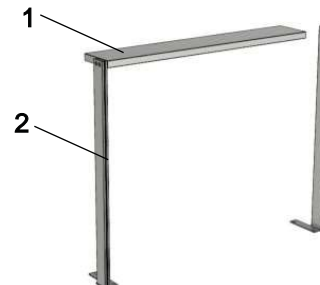

Countertop Wall Upright

*SIGMA FLEX™*  
*49" HIGH COUNTERTOP UPRIGHTS*

**Island Countertop Uprights**

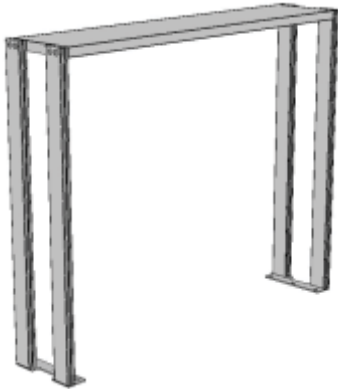

Width	Item Number
24"	BIU1024
30"	BIU1030
36"	BIU1036
42"	BIU1042
48"	BIU1048
54"	BIU1054
60"	BIU1060
66"	BIU1066
72"	BIU1072

- 49" high. 12" deep.
- Countertop upright assemblies can be mounted to any new or existing work surface.
- Accommodates a maximum of 6 Sigma Flex™ shelves, adjustable in 1" increments.
- Ensure work surface is of sufficient strength to support additional load.
- Mounting requires drilling bolt holes in work surface (3/8" countersunk bolts recommended for mounting are included).

**Island Countertop Upright Cover Plates**

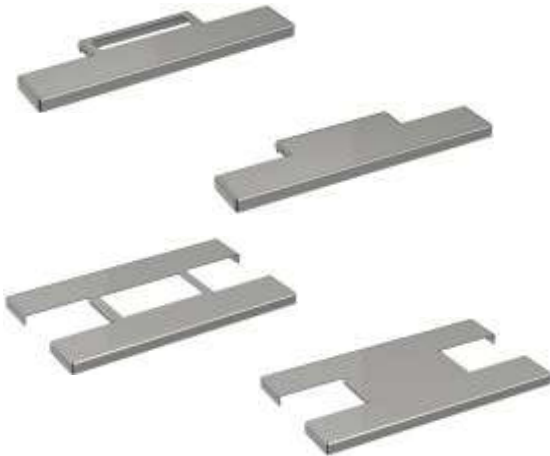

Island Upright Cover Panels	
With Service Cut-outs	Without Service Cut-outs
BIC0001	BIC0000

Island Upright Double Sided Cover Panels	
With Service Cut-outs	Without Service Cut-outs
BIC0003	BIC0002

- For BIU Island Countertop Uprights only.
- Used to cover visible screws that install a BIU.
- Available with and without service cut-out.

**Wall Countertop Uprights**

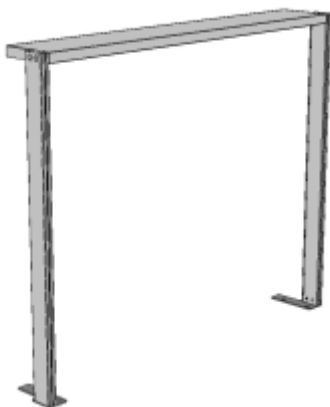

Width	Item Number
24"	BWU1024
30"	BWU1030
36"	BWU1036
42"	BWU1042
48"	BWU1048
54"	BWU1054
60"	BWU1060
66"	BWU1066
72"	BWU1072

- 49" high. 8-3/4" deep.
- Countertop upright assemblies can be mounted to any new or existing work surface.
- Accommodates a maximum of 3 Sigma Flex™ shelves, adjustable in 1" increments.
- Ensure work surface is of sufficient strength to support additional load.
- Mounting requires drilling bolt holes in work surface (3/8" countersunk bolts recommended for mounting are included).

*SIGMA FLEX™*  
*3-1/4" DEEP SINGLE CORE FRAMES*

**Single Core Frames**

Single Core Frames are designed to provide support for shelving when supported by adjacent base cabinets. Core Frames are 3-1/4" deep and offered in various widths and are available in full height assemblies with the option for electrical and data services in the lower panels.

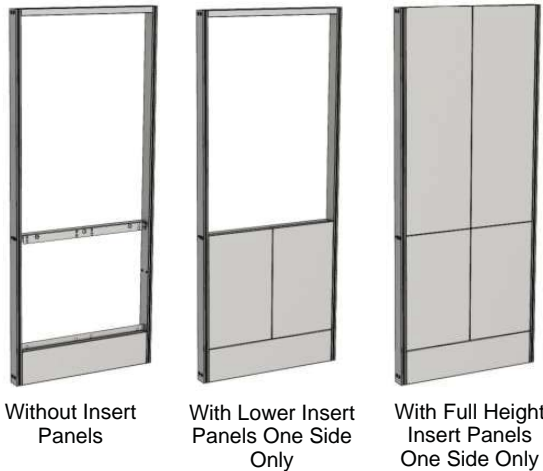

Width	Without Insert Panels	With Lower Insert Panels	With Full Height Insert Panels
24"	SUF1124	SUF1024	SUF1224
30"	SUF1130	SUF1030	SUF1230
36"	SUF1136	SUF1036	SUF1236
42"	SUF1142	SUF1042	SUF1242
48"	SUF1148	SUF1048	SUF1248
54"	SUF1154	SUF1054	SUF1254
60"	SUF1160	SUF1060	SUF1260
66"	SUF1166	SUF1066	SUF1266
72"	SUF1172	SUF1072	SUF1272

- One piece full height assembly is 85" high by 3-1/4" deep.
- Used for island assemblies where single upright is needed and relies on adjacent fixed casework for support and suitable for most wall applications.
- Accepts Sigma Flex™ shelves that are adjustable in 1" increments.
- Work surfaces must be special ordered with notches to allow for uprights, or, panel work surfaces can be used to cover area between uprights.

**3-1/4" Deep Single Core Frame Supports**

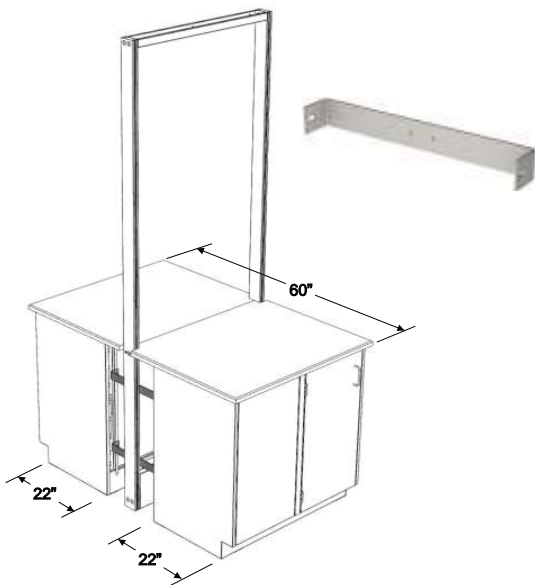

Item Number
SUF0000

- 3-1/4" deep Single Core Frame Supports adds extra support for island assemblies. Comes with four supports.
- Attaches to interior of island core.
- Use with 22" deep base cabinets and supports 60" deep island work surfaces.



*SIGMA FLEX™*  
*1" DEEP WALL RAILS*

**Wall Rails**

Wall Rail systems attaches to the wall to offer support structure when no services are required. Ensure your wall is of sufficient strength to support intended load (significant blocking required). Wall Rails are 1" deep which provides the benefit of no major reduction in lab floor space. Offered in various widths, and available in full height or upper assemblies and can be used with cantilevered work surfaces and shelves. Raised core assemblies are also available as lower or full height wall cores.



*SIGMA FLEX™*  
*1" DEEP WALL RAILS*

**Wall Blocking Guidelines**

Over Counter Wall Rail System

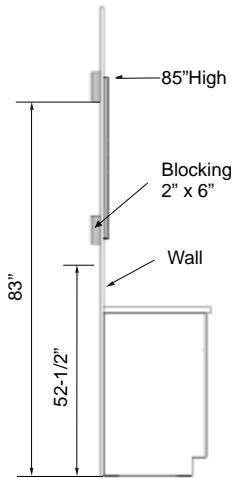

Under Counter Wall Rail System

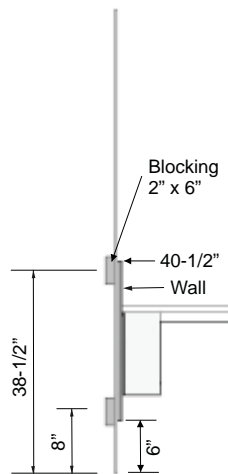

Full Height Wall Rail System

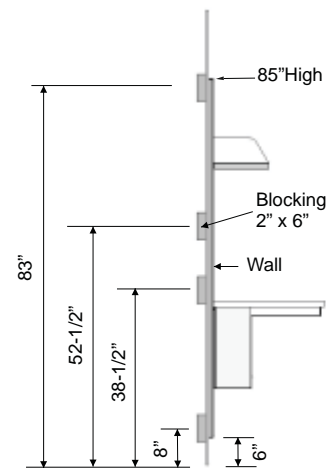

Major wall blocking is essential, do not set up Wall Rails on finished wall without blocking. If non-standard sizes are ordered, please contact Mott for blocking guidelines.

**Load Ratings**

**Load Maximums**

Maximum load ratings are live loads and include loads applied to top of work surface, including total weight of shelves. These capacities should be used as guidelines only. Please contact Mott Manufacturing for specific load requirements. Load ratings should not be exceeded for any surface.

**Maximum Load Ratings**

**Modular Support Structure**

- Suspended Upper Shelves 300lbs
- Cantilevered Work surface 400lbs

**Shelving**

- 8" deep 180lbs
- 12" deep 180lbs
- 18" deep 130lbs
- 24" deep 100lbs

**Suspended Cabinets**

- Base Cabinets 300lbs

**Total Wall Core Assembly**

- Wall Rail System 760lbs

Includes one work surface at 400lbs. each, and components (at their rated loads), not to exceed 360lbs.

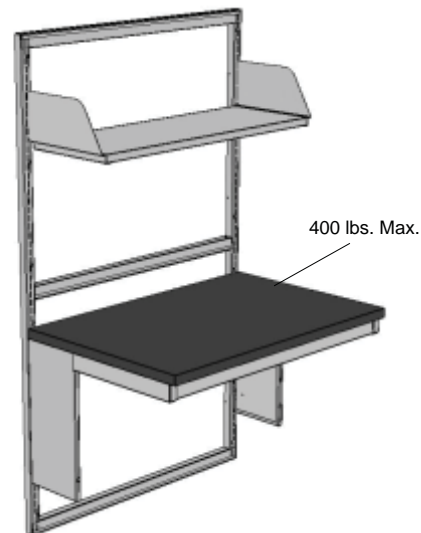

Wall Rail With  
Cantilevered Table

*SIGMA FLEX™*  
*1" DEEP WALL RAILS*

**Full Height Wall Rail Components**

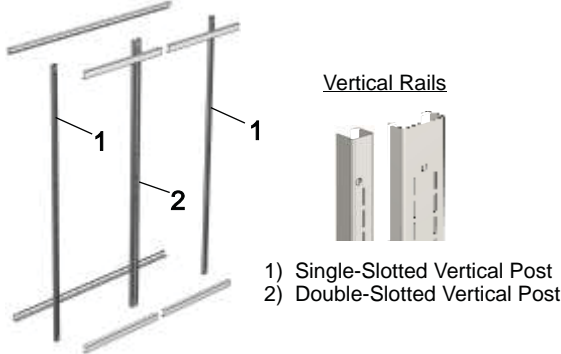

Full Height Vertical Rail	
Single-Slotted	Double-Slotted
WRV1079	WRV1179

- Vertical Rail for full height assembly.
- 79" high by 1" deep.
- Order one double slotted and two single slotted vertical rails for each wall rail structure.
- Rails are slotted in 1" increments.
- Fastens to wall to give support structure where no services are required. Ensure wall is of sufficient strength to support intended load (significant blocking required).
- Optional insert cover panels are available.
- Accepts most Sigma Flex™ shelves and cantilevered work surfaces.

**Half Height Wall Rail Components**

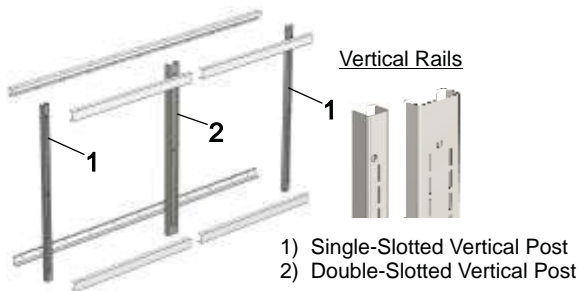

Half Height Vertical Rail	
Single-Slotted	Double-Slotted
WRV1034	WRV1134

- Vertical Rail for above counter or below counter structure.
- 34-1/2" high by 1" deep.
- Order one double slotted and two single slotted vertical rails for each wall rail structure.
- Rails are slotted in 1" increments.
- Fastens to wall to give support structure where no services are required. Ensure wall is of sufficient strength to support intended load (significant blocking required).
- Optional insert cover panels are available.
- Accepts most Sigma Flex™ shelves and cantilevered work surfaces.

**Horizontal Rail**



Item Number
WRH1096

- 8' long by 1" deep.
- Upper and lower rails are included in part number.
- Horizontal Rail provides a 6" adjustability for Double-Slotted Vertical Post.
- Fastens to wall to give support structure where no services are required. Ensure wall is of sufficient strength to support intended load (significant blocking required).
- Optional insert cover panels are available.

**Horizontal Rail Cover**



With	Item Number
24"	WRC0024
30"	WRC0030
36"	WRC0036
42"	WRC0042
48"	WRC0048
54"	WRC0054
60"	WRC0060
66"	WRC0066
72"	WRC0072

- Fastens to Horizontal Rail.
- One set of upper and lower covers are included in part number.
- Dimensions are nominal.

*SIGMA FLEX™*  
*1" DEEP WALL RAILS*

**Full Height Upper Insert Cover Panel**



30" wide unit shown.

Width	Steel Insert Panel
24"	WRP2024
30"	WRP2030
36"	WRP2036
42"	WRP2042
48"	WRP2048
54"	WRP2054
60"	WRP2060
66"	WRP2066
72"	WRP2072

- For upper portion of full height wall rail only.
- Includes Middle Horizontal Rail.
- 44-1/2" high.
- Attaches easily with blind fasteners.

**Half Height Lower Insert Cover Panel**



30" wide unit shown.

Width	Steel Insert Panel
24"	WRP1024
30"	WRP1030
36"	WRP1036
42"	WRP1042
48"	WRP1048
54"	WRP1054
60"	WRP1060
66"	WRP1066
72"	WRP1072

- For half height or lower portion of full height wall rail only.
- Includes Middle Horizontal Rail.
- 34-1/2" high.
- Attaches easily with blind fasteners.

**Island Core Support Panel**

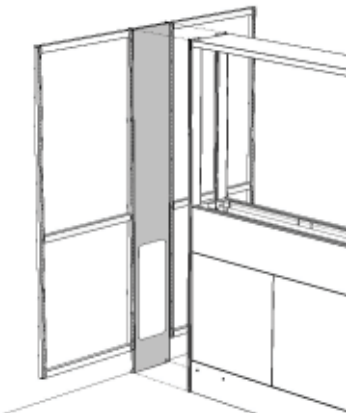

Item Number
CSP1012

- Use to expand an existing wall rail assembly to an island core.
- 85" high. 12" wide.
- Fastens to wall rail assembly with clips.

*SIGMA FLEX™*  
*CORE ACCESSORIES*

**Lower Island and Wall End Filler**

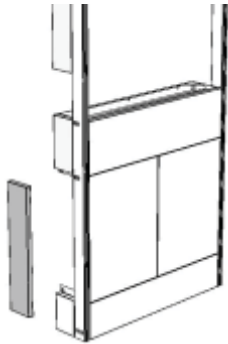

Item Number
FCM0000

- End fillers cover exposed ends of the 12" deep island and 8-3/4" deep wall core assemblies, providing a completed look to your Sigma Flex™ assembly.
- End fillers snap on for easy installation.

**Raised Island and Wall Core End Filler**

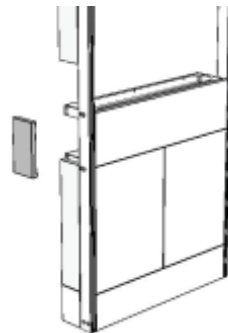

Item Number
FCT0000

- End fillers cover exposed ends of the 12" deep island and 8-3/4" deep wall raised core assemblies, providing a completed look to your Sigma Flex™ assembly.
- End fillers snap on for easy installation.

**Upper Island Core End Fillers - 12" Deep**

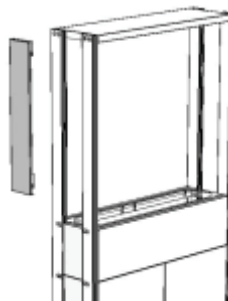

Height	Item Number
24"	FCS2400
30"	FCS3000
36"	FCS3600
48"	FCS4800

- End fillers cover exposed ends of the 12" deep upper island core assembly, providing a completed look to your Sigma Flex™ assembly.
- Height size is based upon the height of the wall cabinet.
- End fillers have a lift off cover for easy installation.

**Upper Wall Core End Fillers - 8-3/4" Deep**

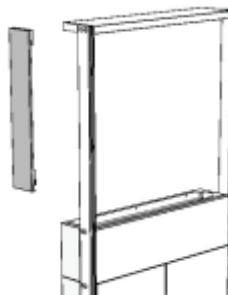

Height	Item Number
24"	FCW2400
30"	FCW3000
36"	FCW3600
48"	FCW4800

- End fillers cover exposed ends of the 8-3/4" deep upper wall core assembly, providing a completed look to your Sigma Flex™ assembly.
- Height size is based upon the height of the wall cabinet.
- End fillers have a lift off cover for easy installation.

*SIGMA FLEX™*  
*CORE ACCESSORIES*

**6" Deep Single Core - End Cover Panel**



**Item Number**  
FCM1000

- End cover panels cover exposed ends of the 6" deep island assemblies, providing a completed look to your Sigma Flex™ assembly.
- End cover panels screw on for easy installation.

**Strut Support**

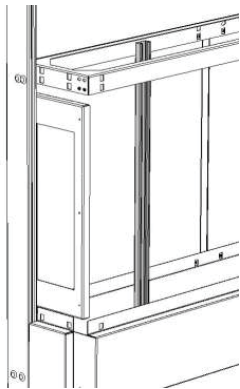

**Item Number**  
VFC1000

- Strut type service line support carries additional support for plumbing or electrical service lines.
- Fastens to interior of island and wall cores.
- Strut height is 26-3/4" high.
- Strut is 1-5/8" X 13/16".

*SIGMA FLEX™*  
*CORE ACCESSORIES*

**Single Work Surface Filler Inserts**



Core Type	1" Thick	1-1/4" Thick
Island Core	FSSW001	FSSW002
Wall Core	FSWW001	FSWW002

- Island and wall core single work surface fillers cover the exposed portion of the 12" deep island core assembly and the 8-3/4" deep wall core assembly, providing a completed look to your Sigma Flex™ assembly.
- For use when reagent core tops are not notched for posts and rectangular work surfaces are required.
- End fillers clip in for easy installation.

**Double Work Surface Filler Inserts**

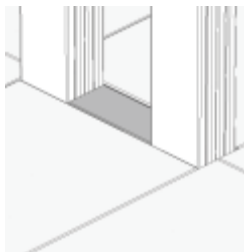

Core Type	1" Thick	1-1/4" Thick
Island Core	FDSW001	FDSW002
Wall Core	FDWW001	FDWW002

- Island and wall core double work surface fillers cover the exposed portion of the 12" deep island core assembly and the 8-3/4" deep wall core assembly, providing a completed look to your Sigma Flex™ assembly.
- For use when reagent core tops are not notched for posts and rectangular work surfaces are required.
- End fillers clip in for easy installation.

**Sigma Flex™ Wall Cabinet Hanger Rails**

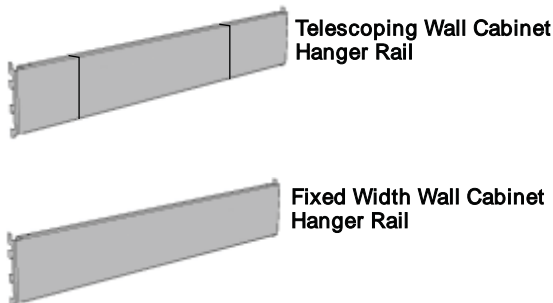

Width	Telescoping Rail	Fixed Width Rail
24"	TWR0024	FWR0024
30"	TWR0030	FWR0030
36"	TWR0036	FWR0036
42"	TWR0042	FWR0042
48"	TWR0048	FWR0048
54"	TWR0054	FWR0054
60"	TWR0060	FWR0060
72"	TWR0072	FWR0072

- Sigma Flex™ Wall Cabinet Hanger Rails are required to hang above-counter storage cabinets on to Sigma Flex™ systems.
- Order rails to match width of support structure frame (Telescoping Rails are not suitable for cabinets smaller than 24" wide).
- Telescoping Rail is adjustable up to 5".
- Wall cabinets must be ordered with option code "FR" to suspend from Sigma Flex™ and Sigma Cart™ products. See wall cabinet section to order cabinets.



*SIGMA FLEX™*  
*CORE ACCESSORIES*

**Island Service Drop - 12" Deep**

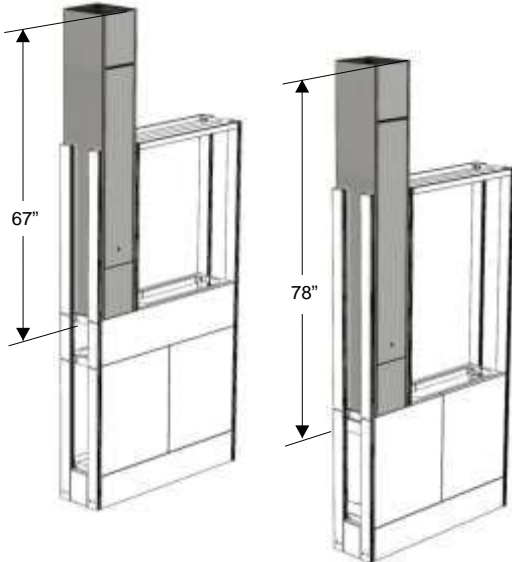

Full Height Island  
Raised Core

Full Height Island Core

Option Code
R1

- Use this option code when ordering Sigma Flex™ 12" deep Island Core assemblies.
- For new installations only.
- For use to run utilities and services on Sigma Flex™ 12" deep island cores and counter top uprights.
- Additional uprights allow for center shelves.
- Center shelves must be ordered 12" less in width to accommodate service drop.
- Detachable inserts are easy to remove, allowing access to services on both sides of service drop.
- Wall cabinets cannot be added with option R1. Due to load capabilities.
- Full Height Island Raised Core with R1 option is a standard height of 67".
- Full Height Island Core with R1 option is a standard height of 78".
- Custom heights are available please specify when ordering.

**Wall Service Drop - 8-3/4" Deep**

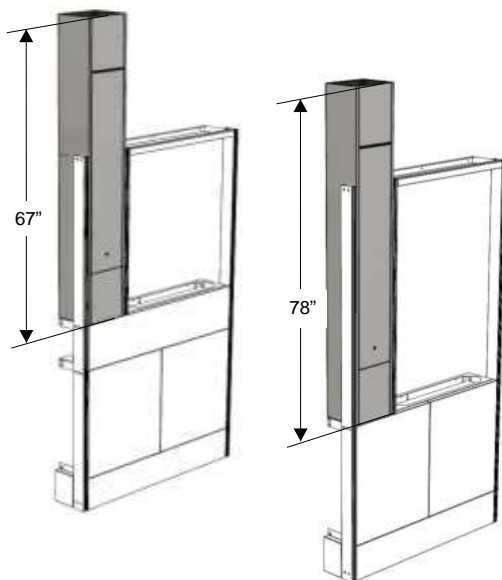

Full Height Wall Core  
with Left Hand Service  
Drop shown

Full Height Wall Raised Core  
with Left Hand Service Drop  
shown

RH Option Code	LH Option Code
R3	R4

- Use this option code when ordering Sigma Flex™ 8-3/4" deep Wall Core assemblies.
- For new installations only.
- For use to run utilities and services on Sigma Flex™ 8-3/4" deep wall cores and counter top uprights.
- Additional uprights allow for center shelves.
- Center shelves must be ordered 12" less in width to accommodate service drop.
- Detachable insert are easy to remove, allowing access to services.
- Wall cabinets cannot be added with option R3 or R4. Due to load capabilities.
- Full Height Wall Raised Core with R3 and R4 option is a standard height of 67".
- Full Height Wall Core with R3 and R4 option is a standard height of 78".
- Custom heights are available please specify when ordering.

*SIGMA FLEX™*  
*CORE ACCESSORIES*

**Corner Island Service Pillars - 12" Deep**

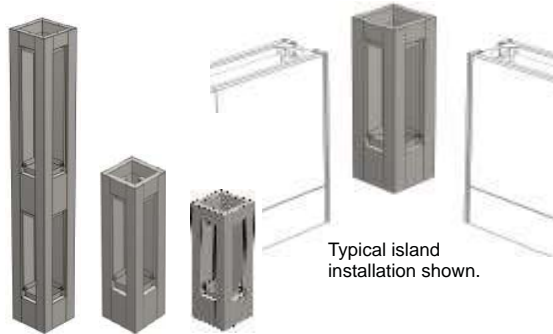

Typical island installation shown.

Pillars for	Item Number
28-3/4"H Core	CPS0000
34-3/4"H Core	CPS1000
45-3/4"H Core	CPS2000
85"H Core	CPS3000

- For use to run utilities and services and goes around corners for island cores.
- Detachable inserts are easy to remove, allowing access to services.
- Pillars bolt to adjacent cores.
- 12" wide by 12" deep. Shipped assembled.
- Panels supplied on 2 sides only.

**Corner Wall Service Pillars - 8-3/4" Deep**

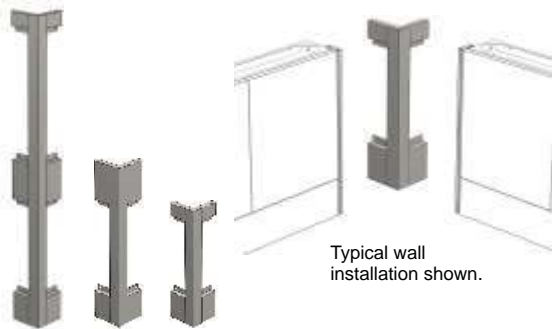

Typical wall installation shown.

Pillars for	Item Number
28-3/4"H Core	CPW0000
34-3/4"H Core	CPW1000
45-3/4"H Core	CPW2000
85"H Core	CPW3000

- For use to run utilities and services and goes around corners for wall cores.
- Detachable inserts are easy to remove, allowing access to services.
- 8-3/4" wide by 8-3/4" deep. Shipped assembled.
- No panels supplied.

**Peninsula Service Pillars - 8-3/4" Deep**

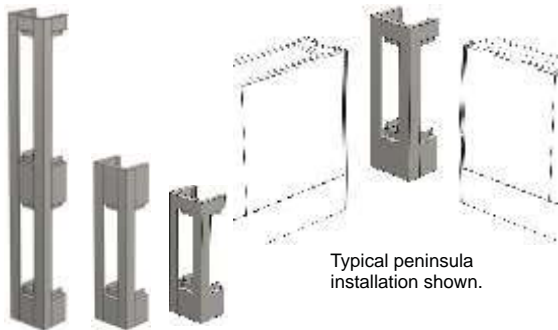

Typical peninsula installation shown.

Pillars for	Item Number
28-3/4"H Core	CPP0000
34-3/4"H Core	CPP1000
45-3/4"H Core	CPP2000
85"H Core	CPP3000

- For use to run utilities and services on peninsulas and goes around corners for island and wall cores.
- Detachable inserts are easy to remove, allowing access to services.
- 12" wide by 8-3/4" deep. Shipped assembled.
- No panels supplied.

**Corner Island Service Pillars - 6" Deep**

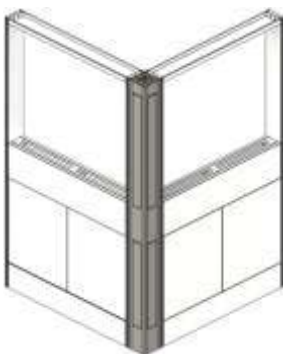

Pillars for	Item Number
28-3/4"H Core	CPS0006
34-3/4"H Core	CPS1006
45-3/4"H Core	CPS2006
85"H Core	CPS3006

- For use to run utilities and services and goes around corners for island cores.
- Detachable inserts are easy to remove, allowing access to services.
- Pillars bolt to adjacent cores.
- 6" wide by 6" deep. Shipped assembled.
- Panels supplied on 2 sides only.

*SIGMA FLEX™*  
*TABLES FRAMES*

**Cantilevered Table Frames**

Cantilevered Table Frames are manufactured to fasten to Sigma Flex™ support assemblies, providing support for suspended cabinets.

**Cantilevered Table Frames - 23" Deep**



Width	Item Number
24"	CCS0024
30"	CCS0030
36"	CCS0036
42"	CCS0042
48"	CCS0048
54"	CCS0054
60"	CCS0060
66"	CCS0066
72"	CCS0072

- Table frame is 23" deep by 18" high and to be used with 24" deep work surface (work surface not included).
- 23" deep table frame will hold cabinets with a total combined width of 3" less than the table frame.
- Complete with hanging rails to suspend casework.
- Can be vertically adjusted in 1" increments.
- Includes a surface leveling system.
- Space at the rear edge of frame to allow for cable drop
- Consult Mott Manufacturing if supporting cantilevered frame on "L" shapes wider than 8' or any straight island 6" core.

**Cantilevered Table Frames - 29" Deep**



Width	Item Number
24"	CCS1024
30"	CCS1030
36"	CCS1036
42"	CCS1042
48"	CCS1048
54"	CCS1054
60"	CCS1060
66"	CCS1066
72"	CCS1072

- Table frame is 29" deep by 18" high and to be used with 30" deep work surface (work surface not included).
- 29" deep table frame will hold cabinets with a total combined width equal to the width of the table frame.
- Complete with hanging rails to suspend casework.
- Can be vertically adjusted in 1" increments.
- Includes a surface leveling system.
- Space at the rear edge of frame to allow for cable drop.
- Consult Mott Manufacturing if supporting cantilevered frame on "L" shapes wider than 8' or any straight island 6" core.

**Cantilevered Corner Table Support Frames**



Core Width	23" Deep	29" Deep
36" X 36"	CCS2336	CCS2936
48" X 48"	CCS2348	CCS2948

- Table frame available 23" or 29" deep by 18" high (work surface not included).
- Includes rear support bracket.
- Table frame cannot suspend casework.
- Can be vertically adjusted in 1" increments.
- Includes a surface leveling system.
- Space at the rear edge of frame to allow for cable drop.

*SIGMA FLEX™  
SHELVES*

**Shelves**

Sigma Flex™ is designed and manufactured to accommodate upper storage cabinets and shelving. Shelves are adjustable in height and available in various widths for island and wall cores. By combining inner and outer shelves at the same height, you can achieve up to five feet of shelf depth at a single level.

**Outer and Top Shelves**

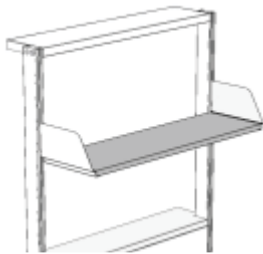

Steel Shelves							
Width	6" Deep	8" Deep	10" Deep	12" Deep	14" Deep	18" Deep	24" Deep
24"	FSH0624	FSH0824	FSH1024	FSH1224	FSH1424	FSH1824	FSH2424
30"	FSH0630	FSH0830	FSH1030	FSH1230	FSH1430	FSH1830	FSH2430
36"	FSH0636	FSH0836	FSH1036	FSH1236	FSH1436	FSH1836	FSH2436
42"	FSH0642	FSH0842	FSH1042	FSH1242	FSH1442	FSH1842	FSH2442
48"	FSH0648	FSH0848	FSH1048	FSH1248	FSH1448	FSH1848	FSH2448
54"	FSH0654	FSH0854	FSH1054	FSH1254	FSH1454	FSH1854	FSH2454
60"	FSH0660	FSH0860	FSH1060	FSH1260	FSH1460	FSH1860	FSH2460
66"	FSH0666	FSH0866	FSH1066	FSH1266	FSH1466	FSH1866	FSH2466
72"	FSH0672	FSH0872	FSH1072	FSH1272	FSH1472	FSH1872	FSH2472

Wood Shelves							
Width	6" Deep	8" Deep	10" Deep	12" Deep	14" Deep	18" Deep	24" Deep
24"	FSH0624W	FSH0824W	FSH1024W	FSH1224W	FSH1424W	FSH1824W	FSH2424W
30"	FSH0630W	FSH0830W	FSH1030W	FSH1230W	FSH1430W	FSH1830W	FSH2430W
36"	FSH0636W	FSH0836W	FSH1036W	FSH1236W	FSH1436W	FSH1836W	FSH2436W
42"	FSH0642W	FSH0842W	FSH1042W	FSH1242W	FSH1442W	FSH1842W	FSH2442W
48"	FSH0648W	FSH0848W	FSH1048W	FSH1248W	FSH1448W	FSH1848W	FSH2448W
54"	FSH0654W	FSH0854W	FSH1054W	FSH1254W	FSH1454W	FSH1854W	FSH2454W
60"	FSH0660W	FSH0860W	FSH1060W	FSH1260W	FSH1460W	FSH1860W	FSH2460W

- Shelf suitable for any Sigma Flex™ support structure or Sigma Cart™.
- Attach to shelf brackets with screws (screws not included).
- Nominal width.
- To order Under Mount Shelf Task Light refer to steel Miscellaneous Section.
- For wood shelving options see page N8.

**Optional Steel Shelf Angles**

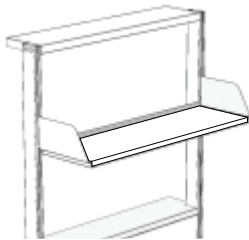

- Shelf with rear angle is suitable for any Sigma Flex™ structure or Sigma Cart™.
- Attach to shelf brackets with screws (screws not included).
- Use option codes below to add angles to steel shelves only:
  - AR (Rear Shelf Angle welded to shelf)
  - AF (Front Shelf Angle welded to shelf)
  - AB (Rear and Front Shelf Angle welded to shelf)

**Wood Shelving Options**

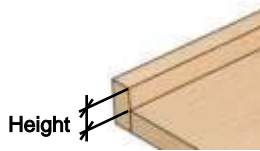

Height	Back Lip	Front Lip	Back & Front Lip
1"	ARW1	AFW1	ABW1
2"	ARW2	AFW2	ABW2
3"	ARW3	AFW3	ABW3
4"	ARW4	AFW4	ABW4

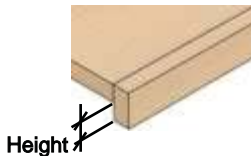

Height	Front Valance
1"	FV1
2"	FV2
3"	FV3
4"	FV4

- Height of the lip is measured from the top of the shelf to the top of the lip. Lip is 3/4" thick.
- Shelves are 1" thick.
- Height of the valance is measured from the bottom of the shelf to the bottom of the valance. Valance is 3/4" thick.
- Shelves are 1" thick.

**Island Center Shelf Brackets - 12" Deep**

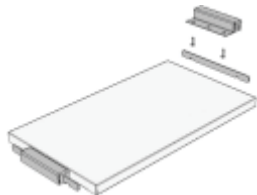

Item Number
FSB2012

- Pair of brackets designed for non-metal center shelves for 12" deep Sigma Flex™ cores (part numbers - FSL's, FSF's, BIU's).
- Installed between uprights on the inside of the island core upper frames.
- Adjustable in 1" increments.
- Attach to Sigma Flex™ uprights with screws.

*SIGMA FLEX™  
SHELVES*

**Island Center Shelves - 12" Deep**

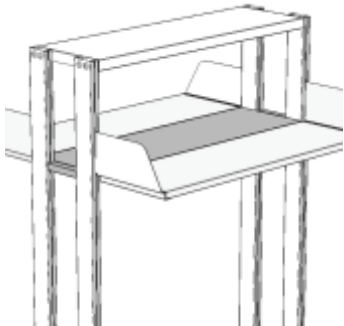

Width	Steel Shelves	Wood Shelves
24"	FSC1224	FSC1224W
30"	FSC1230	FSC1230W
36"	FSC1236	FSC1236W
42"	FSC1242	FSC1242W
48"	FSC1248	FSC1248W
54"	FSC1254	FSC1254W
60"	FSC1260	FSC1260W
66"	FSC1266	FSC1266W
72"	FSC1272	FSC1272W

- Shelf designed for 12" deep Sigma Flex™ cores (part numbers - FSL's, FSF's, BIU's)
- Installed between uprights on the inside of the island core upper frames.
- Complete with brackets and keys.
- Nominal width.

**Outer Shelf Brackets**

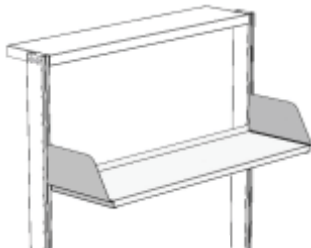

Depth	Item Number
6"	FSB0006
8"	FSB0008
10"	FSB0010
12"	FSB0012
14"	FSB0014
18"	FSB0018
24"	FSB0024

- Pair of steel end brackets designed to fit Outer Shelf and can be used for shelves of different materials.
- Adjustable in 1" increments.
- Brackets only compatible with Sigma Flex™ structures or Sigma Cart™.

**15° Angled Outer Shelf Brackets**



Depth	Item Number
10"	ASB0010
12"	ASB0012
14"	ASB0014
16"	ASB0016
18"	ASB0018

- Pair of steel end brackets designed to fit Outer Shelves and can be used for shelves of different materials.
- Shelf brackets designed at a fixed 15 degree angle.
- Adjustable in 1" increments.
- Brackets only compatible with Sigma Flex™ structures or Sigma Cart™.

**Top Shelf Brackets**



Depth	Item Number
6"	FIB0006
8"	FIB0008
10"	FIB0010
12"	FIB0012
14"	FIB0014
18"	FIB0018
24"	FIB0024

- Pair of steel top end brackets designed to fit Outer Shelf and can be used for shelves of different materials.
- Adjustable in 1" increments.
- Brackets only compatible with Sigma Flex™ structures or Sigma Cart™.

*SIGMA FLEX™  
SHELVES*

**Radius Top Shelf Brackets**



Depth	Item Number
6"	FIB3006
8"	FIB3008
10"	FIB3010
12"	FIB3012
14"	FIB3014
18"	FIB3018
24"	FIB3024

- Pair of steel top end brackets designed to fit Outer Shelf and can be used for shelves of different materials.
- Adjustable in 1" increments.
- Brackets only compatible with Sigma Flex™ structures or Sigma Cart™.

**Radius Outer Shelf Brackets**



Depth	Item Number
6"	FSB3006
8"	FSB3008
10"	FSB3010
12"	FSB3012
14"	FSB3014
18"	FSB3018
24"	FSB3024

- Pair of steel end brackets designed to fit Outer Shelf and can be used for shelves of different materials.
- Adjustable in 1" increments.
- Brackets only compatible with Sigma Flex™ structures or Sigma Cart™.

**Tapered Top Shelf Brackets**



Depth	Item Number
6"	FIB4006
8"	FIB4008
10"	FIB4010
12"	FIB4012
14"	FIB4014
18"	FIB4018
24"	FIB4024

- Pair of steel top end brackets designed to fit Outer Shelf and can be used for shelves of different materials.
- Adjustable in 1" increments.
- Brackets only compatible with Sigma Flex™ structures or Sigma Cart™.

**Tapered Outer Shelf Brackets**



Depth	Item Number
6"	FSB4006
8"	FSB4008
10"	FSB4010
12"	FSB4012
14"	FSB4014
18"	FSB4018
24"	FSB4024

- Pair of steel end brackets designed to fit Outer Shelf and can be used for shelves of different materials.
- Adjustable in 1" increments.
- Brackets only compatible with Sigma Flex™ structures or Sigma Cart™.



*SIGMA FLEX™  
SHELVES*

**Wall Center Shelves - 8-3/4" Deep**

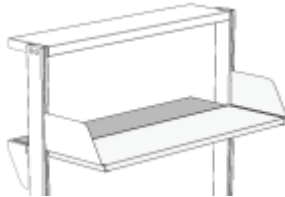

Depth	Steel Shelves	Wood Shelves
24"	FSW0924	FSW0924W
30"	FSW0930	FSW0930W
36"	FSW0936	FSW0936W
42"	FSW0942	FSW0942W
48"	FSW0948	FSW0948W
54"	FSW0954	FSW0954W
60"	FSW0960	FSW0960W
66"	FSW0966	FSW0966W
72"	FSW0972	FSW0972W

- Shelf designed for wall conditions, only between back of upright and wall on 8-3/4" deep Sigma Flex™ wall cores (part number - FLW's).
- Nominal width.

**Wall Center Shelf Brackets**



Item Number
FSB1006

- Pair of steel end brackets 5-1/4" deep used to support Wall Center Shelf between back of upright and wall.
- Adjustable in 1" increments.
- Brackets only compatible with Sigma Flex™ 8-3/4" Deep Wall Core assemblies.
- This bracket cannot be modified.

**Monitor Arm and Mounting Brackets**



Item Number	
Anodized Silver Finish	Black Finish
MONARMA	MONARMF

- LCD Monitor Arm with brackets to attach to Sigma Flex™ uprights.
- Adjustable in 1" increments.
- Brackets only compatible with Sigma Flex™ and Sigma Carts™ structures.

**Under Mount Shelf Task Lights**



Length of Light	Item Number
14"	TLW0014
23"	TLW0023
36"	TLW0036
48"	TLW0048
59"	TLW0059

- **Order light a minimum 6" shorter than the shelf.**
- Low profile (.98" wide by 1.65" high) T5 fluorescent task light mounts to underside of the shelf.
- Shatterproof polycarbonate lens protects the lamp.
- Easily linkable in one continuous line using Flexible Connectors. 6" Flexible Connector comes standard with each light. See below to order longer Flexible Connectors.
- On-off rocker switch located on the side of the fixture.
- 8000 hour, cool white replaceable T5 lamp included.
- UL listed.
- Ships loose, includes Mott's mounting brackets.

**Task Light Flexible Connectors**



Width	Item Number
12"	LFC0012
24"	LFC0024
36"	LFC0036

- Flexible Connector allows to easily link T5 fluorescent lights in one continuous line.



*SIGMA FLEX™*  
*SERVICE COMPONENTS*

**Single Sided Sigma Flex™ Service Channels**

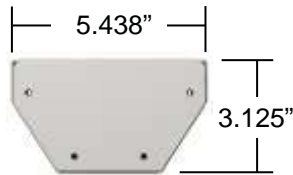

Electrical Service Channel	
Height	Item Number
12"H	SFC1100
24"H	SFC2100

- Heights available in 12" and 24".
- Cutouts only provided, fixtures, cover plates and plugs not included.
- Two electrical cutouts on a 12" high and four electrical cutouts on a 24" high.
- Not pre-wired. If required please contact Mott.
- Complete with mounting bracket.

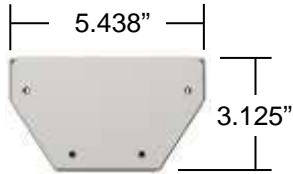

Fixture Service Channel	
Height	Item Number
12"H	SFC1200
24"H	SFC2200

- Heights available in 12" and 24".
- Cutouts only provided, fixtures, cover plates and plugs not included.
- Two plumbing cutouts on a 12" high and four plumbing cutouts on 24" high.
- Not pre-plumbed. If required please contact Mott.
- Complete with mounting bracket.

**Double Sided Sigma Flex™ Service Channels**

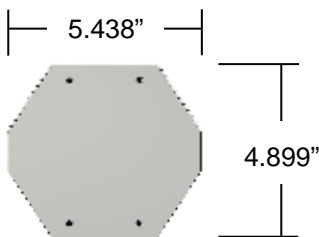

Electrical Service Channel	
Height	Item Number
12"H	DFC1100
24"H	DFC2100

- Heights available in 12" and 24".
- Cutouts only provided, fixtures, cover plates and plugs not included.
- Four electrical cutouts on a 12" high and eight electrical cutouts on a 24" high.
- Not pre-wired. If required please contact Mott.
- Complete with mounting bracket.

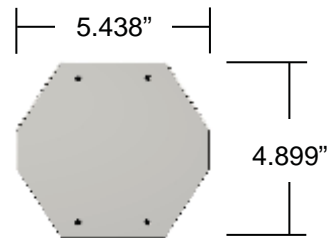

Fixture Service Channel	
Height	Item Number
12"H	DFC1200
24"H	DFC2200

- Heights available in 12" and 24".
- Cutouts only provided, fixtures, cover plates and plugs not included.
- Four plumbing cutouts on a 12" high and eight plumbing cutouts on 24" high.
- Not pre-plumbed. If required please contact Mott.
- Complete with mounting bracket.

*SIGMA FLEX™  
WALL PILASTERS*

**Sigma Flex™ Wall Pilasters**

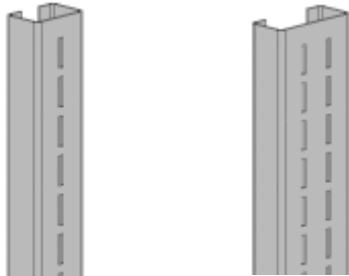

Height	Single Slotted	Double Slotted
18"	FPA1018	FPA0018
24"	FPA1024	FPA0024
30"	FPA1030	FPA0030
36"	FPA1036	FPA0036
42"	FPA1042	FPA0042
48"	FPA1048	FPA0048
60"	FPA1060	FPA0060
72"	FPA1072	FPA0072
96"	FPA1096	FPA0096

- Single Slotted Pilasters are 13/16" deep by 1-1/4" wide.
- Double Slotted Pilasters are 13/16" deep by 2-1/2" wide.
- Pilasters are adjustable in 1" increments.
- Fastens to wall to give support structure where no services are required.
- Ensure wall is of sufficient strength to support intended load (significant blocking required).
- Accepts Sigma Flex™ shelves and brackets.

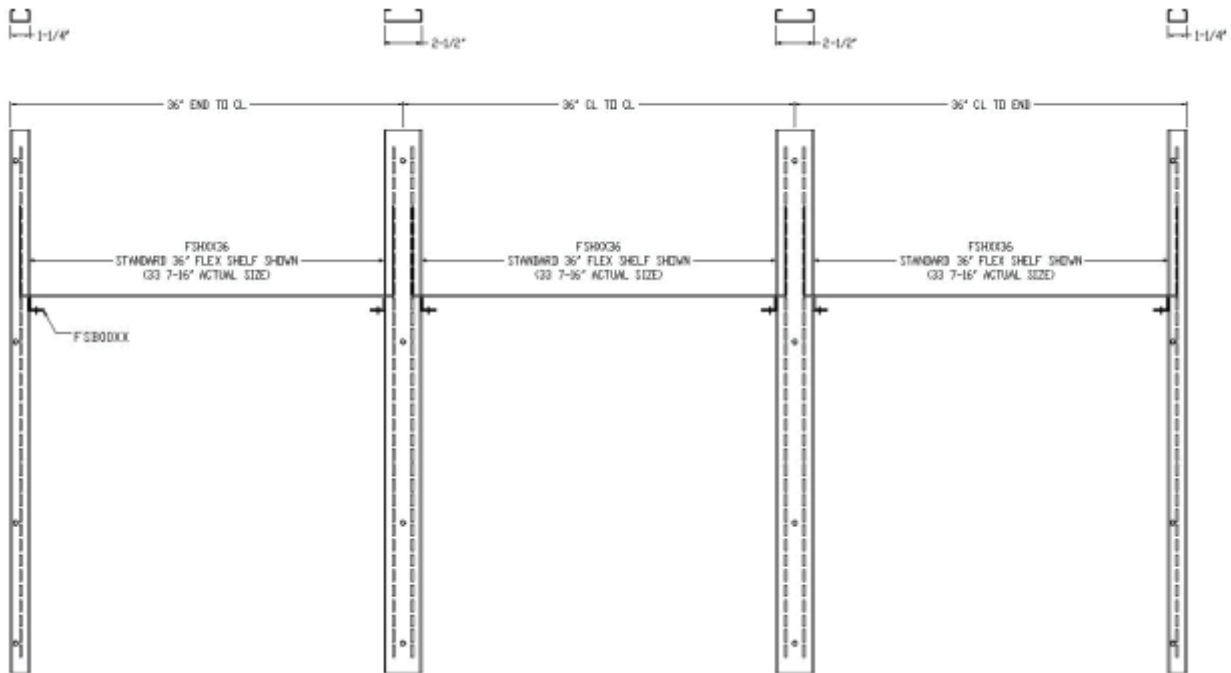

*OPTIMA™*  
*ADAPTABLE LABORATORY FURNITURE SOLUTIONS*

**Optima™ Laboratory Bench System**

The Optima™ Laboratory Bench system has been designed to adapt to an array of laboratory processes, equipment and users. It conveniently supplies all the services and features required for today's laboratory in a self-contained and self-standing bench assembly. This stylish system is available in different designs with the option of a powder coated steel finish or stainless steel.

With the Optima™ system, laboratories can be easily created, changed and reconfigured for new applications or changing space. Integrated services deliver quick and easy access while providing superior flexibility by keeping the work surface open. Plumbing, electrical and data services are factory installed and designed to quick connect to ceiling mounted service panels or overhead service carriers. The Optima™ system provides the ultimate answer to flexibility by offering adjustable work surfaces and shelving to accommodate the ever-changing requirements in today's laboratories.



**Optima™ 2500 Series Laboratory**  
Bench systems can be found on pages  
T2 - T16

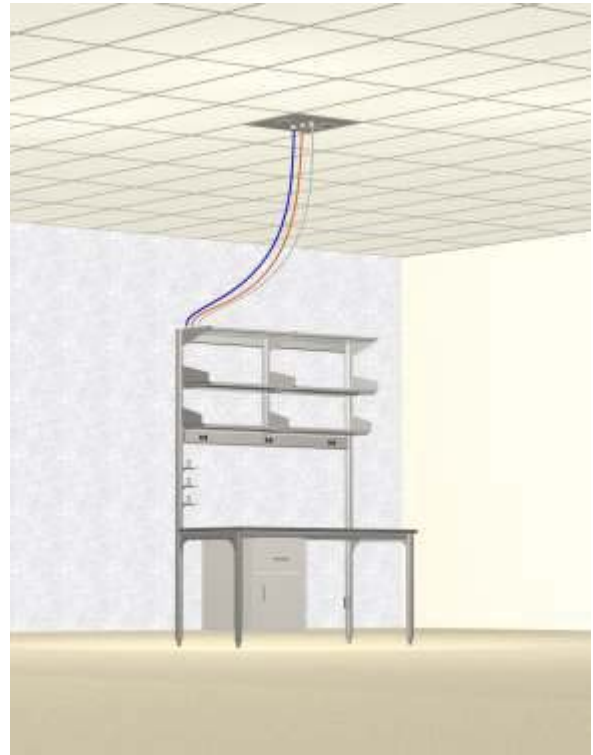

**Optima™ 2100 Series Laboratory**  
Bench systems can be found on pages  
T17 - T27

**Note: Double Sided Assembly as shown  
is not available in the USA.**

**For additional information and help in planning contact Mott Manufacturing.**

*OPTIMA™  
2550 SERIES LABORATORY BENCH SYSTEM*

Optima™ 2550 adapts to an array of laboratory processes, equipment, and users. This system offers increased flexibility by providing a freestanding bench with an integrated stand alone table all at the same price of our Optima™ 2500 laboratory bench system.



Four legged table is easily removable without tools and can be used as a self-supporting work area anywhere in your lab. Before removing the four leg table the above shelves should be removed.

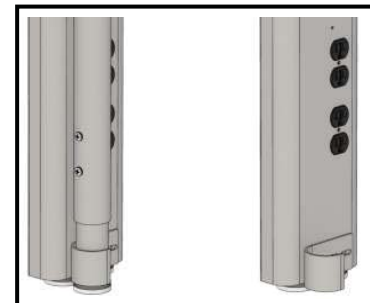

Front of bench is independent and freestanding round leg table without uprights or shelving and docks almost invisibly into the upright. Held in place by clips at the bottom of the frame.

- Overall assembly is 84" high, 2" x 6" deep rear posts with leveling feet, comes complete with cantilevered table frame and freestanding round leg table (without uprights).
- Table frame is height adjustable in 1" increments from 29" to 36" (work surface not included).
- Available in 58" and 70" depths, overall depth does not include work surface.
- Shelves and end panels are not included and must be ordered separately.
- Complete with hanging rails to suspend lower cabinets on units 72" wide and smaller. To order suspended base cabinets and mobile cabinets refer to that catalog sections (assemblies larger than 72" wide cannot suspend cabinets).
- A maximum of three plumbing fixtures are available on the plumbing post.
- Four electrical receptacles are standard in lower electrical post.
- Utility channel will have electrical and data provisions, see page T6 for details.
- Available in powder coated steel finish or stainless steel.
- Ships partially assembled.
- Please indicate Optima™ 2550 when ordering.

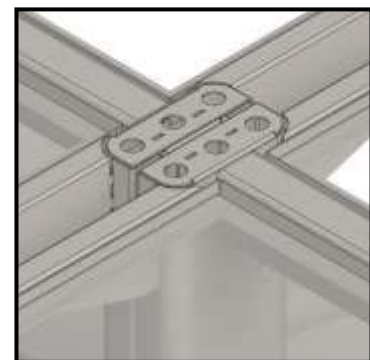

Profile is flat on the exterior side of the bench and is rounded on the inside which provides a clean and uniform appearance when benches are sequenced.

**NOTE:** Please contact Mott Manufacturing for maximum load ratings.

*OPTIMA™  
2500 SERIES LABORATORY BENCH SYSTEM*

**Typical Assemblies**



**Double Sided Assembly**

**Note:** Double Sided Assembly as shown is not available in the USA.



**Single Sided Assembly**



**Stationary Table**



**Tech Desk Station**

*OPTIMA™  
2500 SERIES LABORATORY BENCH SYSTEM*

**Parts List**

- 1) Optima™ 2500 Series 6" Rear Post Assembly
  - 2) Optima™ 2500 Series Table Assembly
  - 3) Optima™ 2500 Series Upper Cross Member
  - 4) Optima™ 2500 Series Center Post Assembly
  - 5) Optima™ 2500 Series Lower Cross Member
  - 6) Optima™ 2500 Series Electrical/Data Raceway
- Note:** Drawing shown of a 60" wide Single Sided Assembly

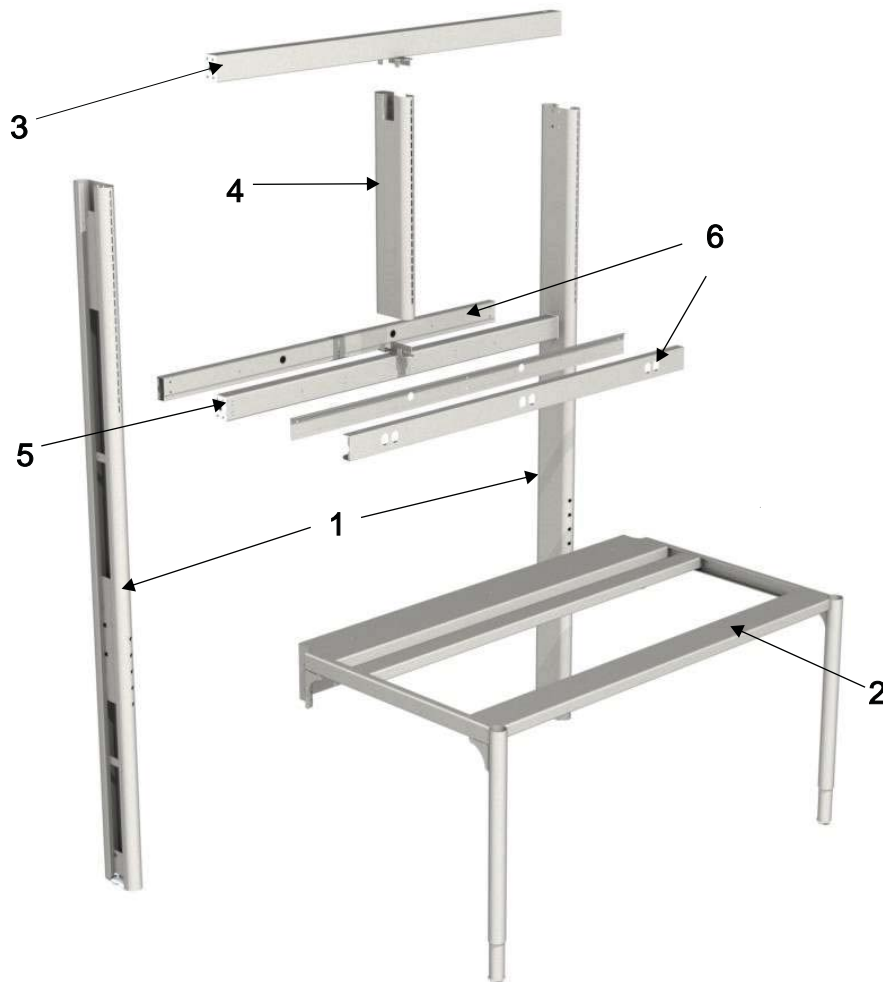

**NOTE:** Please contact Mott Manufacturing for maximum load ratings.

*OPTIMA™*  
*2500 SERIES LABORATORY BENCH SYSTEM*

**Single Sided Assembly Circuit Options**

**WIRING OPTION A**

Option code "C1": 2 circuits  
48" WIDE ASSEMBLY

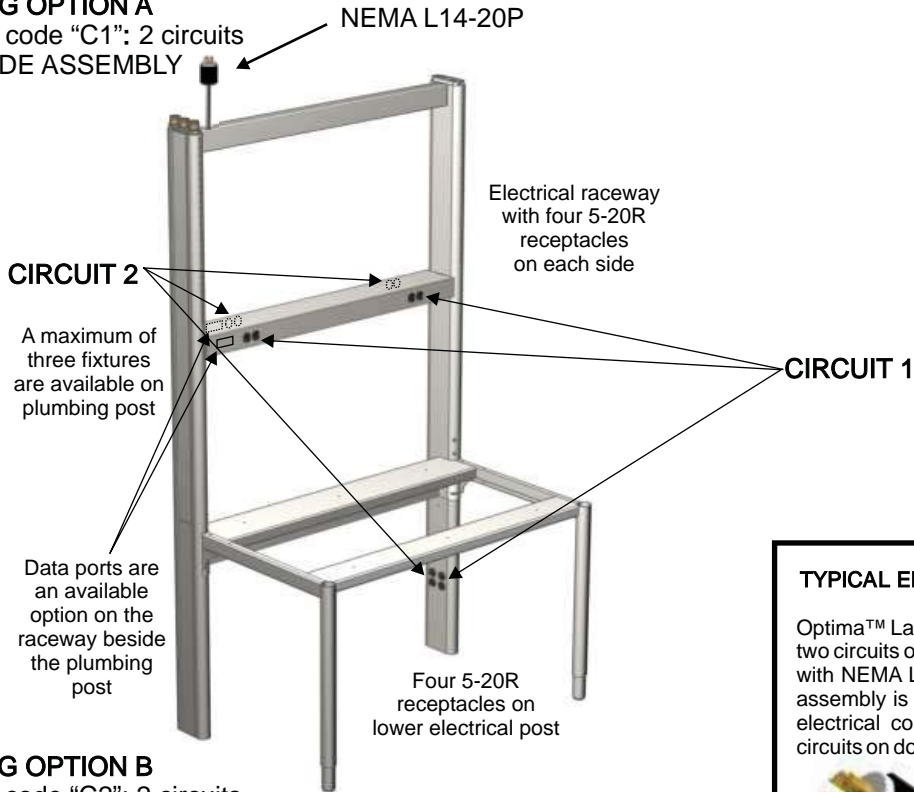

**WIRING OPTION B**

Option code "C2": 2 circuits  
60", 72" & 96" WIDE ASSEMBLY

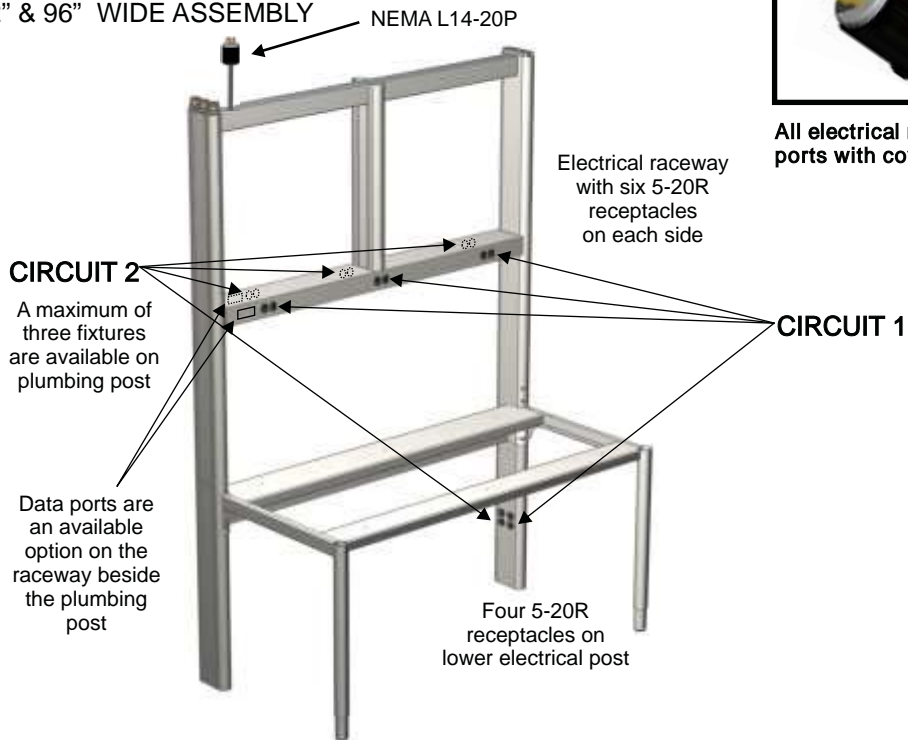

**TYPICAL ELECTRICAL PLUG DETAIL**

Optima™ Laboratory Bench systems with two circuits or more are typically equipped with NEMA L14-20P locking plugs. Each assembly is supplied with 4 feet of black electrical cord. Requires 2X 120V, 20A circuits on double pole circuit breaker.

All electrical receptacles and data ports with cover are black.



Note: Double Sided Assembly as shown is not available in the USA.

*OPTIMA™*  
*2500 SERIES LABORATORY BENCH SYSTEM*

**Double Sided Assembly Circuit Options**

**WIRING OPTION A**

Option code "C1": 2 circuits on a double pole circuit breaker  
48" WIDE ASSEMBLY

NEMA L14-20P

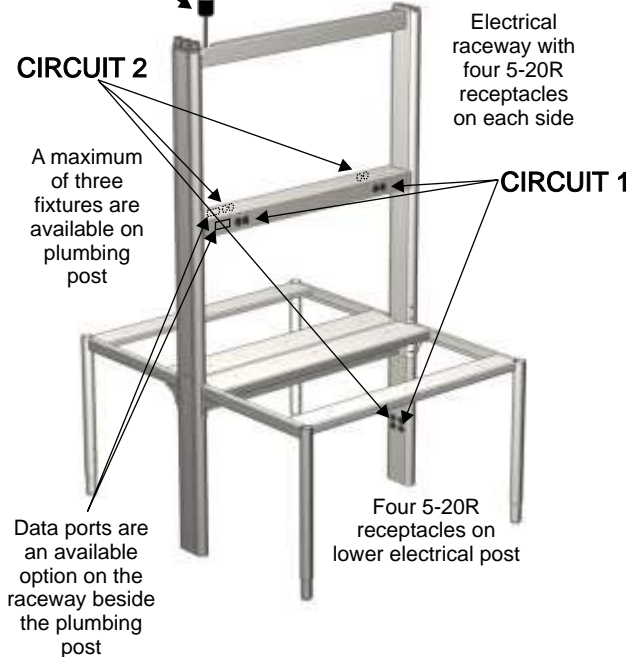

**WIRING OPTION B**

Option code "C2": 2 circuits on a double pole circuit breaker  
60", 72" & 96" WIDE ASSEMBLY

NEMA L14-20P

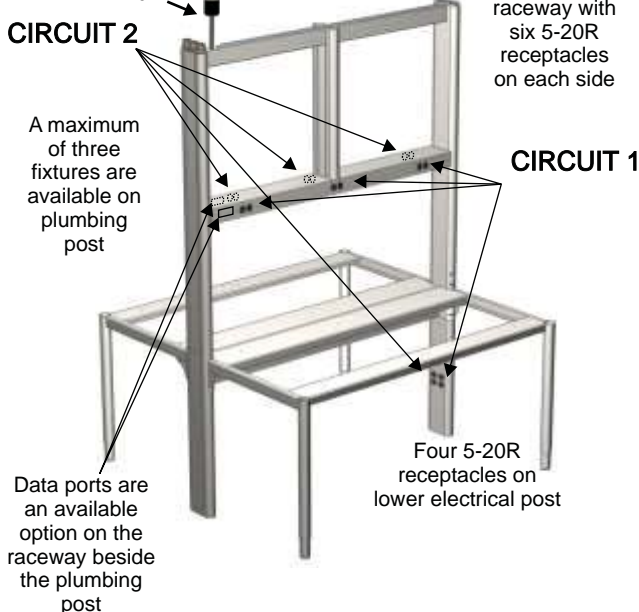

**WIRING OPTION C**

Option code "C3": 4 circuits on a double pole circuit breakers  
48" WIDE ASSEMBLY

NEMA L14-20P

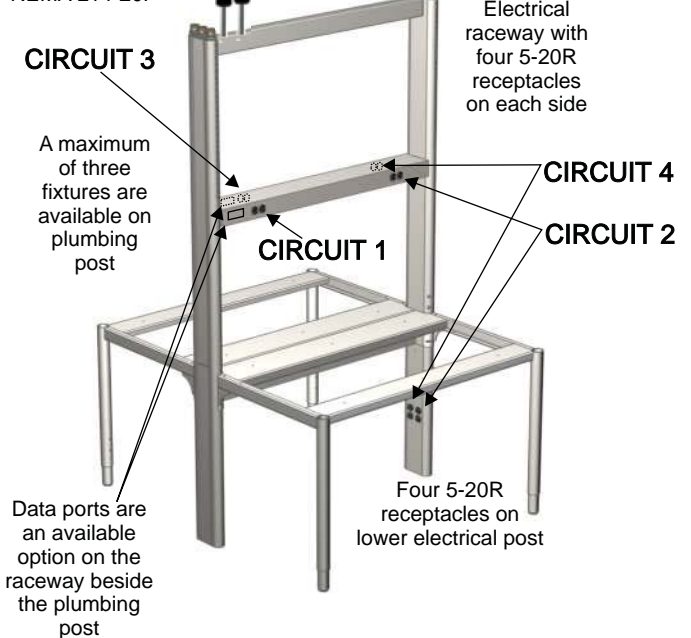

**WIRING OPTION D**

Option code "C4": 4 circuits on a double pole circuit breakers  
60", 72" & 96" WIDE ASSEMBLY

NEMA L14-20P

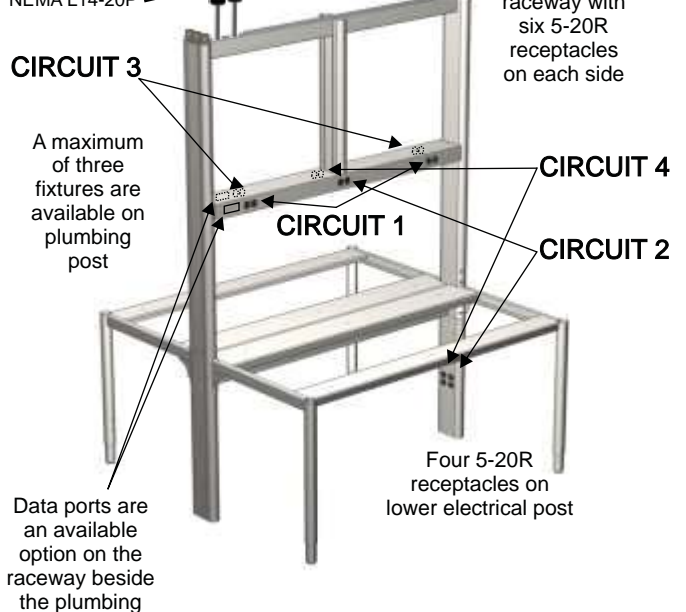

*OPTIMA™*  
*2500 SERIES LABORATORY BENCH SYSTEM*

**Work Surfaces**

Four Leg Table Work Surface for 28" deep or 34" deep units (1" overhang at the front and back).



Four Leg Table Work Surface (1" overhang at front & back)				
Width of Bench	Black Epoxy		Stainless Steel	
	30" Deep	36" Deep	30" Deep	36" Deep
48"	EOP3048	EOP3648	SOP3048	SOP3648
60"	EOP3060	EOP3660	SOP3060	SOP3660
72"	EOP3072	EOP3672	SOP3072	SOP3672
96"	EOP3096	EOP3696	SOP3096	SOP3696

- Stainless steel work surfaces are type 304-4, flat, square edges, stainless steel hat channel construction, 1" thick.
- Epoxy work surfaces are 1" thick.

Single Sided Assembly Work Surface for 32" deep and 38" deep units (1" overhang at front).

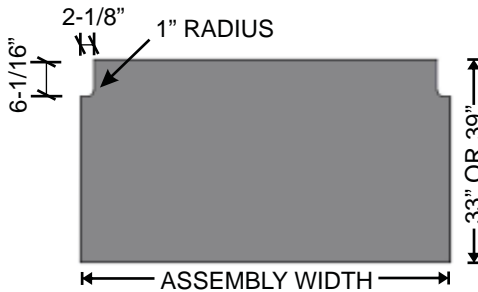

Single Sided Assembly Work Surface (1" overhang at front)				
Width of Bench	Black Epoxy		Stainless Steel	
	33" Deep	39" Deep	33" Deep	39" Deep
48"	EOS3348	EOS3948	SOS3348	SOS3948
60"	EOS3360	EOS3960	SOS3360	SOS3960
72"	EOS3372	EOS3972	SOS3372	SOS3972
96"	EOS3396	EOS3996	SOS3396	SOS3996

- Stainless steel work surfaces are type 304-4, flat, square edges, stainless steel hat channel construction, 1" thick.
- Epoxy work surfaces are 1" thick.

Double Sided Assembly Work Surface for 58" deep and 70" deep units (1" overhang at front). One work top required per side.

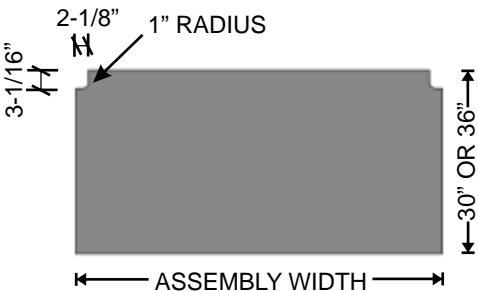

Double Sided Assembly Work Surface (1" overhang at front)				
Width of Bench	Black Epoxy		Stainless Steel	
	30" Deep	36" Deep	30" Deep	36" Deep
48"	EOD3048	EOD3648	SOD3048	SOD3648
60"	EOD3060	EOD3660	SOD3060	SOD3660
72"	EOD3072	EOD3672	SOD3072	SOD3672
96"	EOD3096	EOD3696	SOD3096	SOD3696

- Part numbers are for one work surface only. Two work surfaces are required for a Double Sided Assembly.
- These work surfaces can also be used for Two Leg Frame units.
- Stainless steel work surfaces are type 304-4, flat, square edges, stainless steel hat channel construction, 1" thick.
- Epoxy work surfaces are 1" thick.

*OPTIMA™*  
*2500 SERIES LABORATORY BENCH SYSTEM*

**Single Sided Assemblies**



48" wide unit



60", 72" & 96" wide unit

Width	32" Deep	38" Deep
48"	VOA0248	VOA0348
60"	VOA0260	VOA0360
72"	VOA0272	VOA0372
96"	VOA0296	VOA0396

- Available in powder coated steel finish or stainless steel.
- Overall assembly is 84" high, 6" deep rear posts with leveling feet and comes complete with cantilevered table frame. Height adjustable in 1" increments from 29" to 36" (work surface not included).
- Complete with hanging rails to suspend lower cabinets on units 72" wide and smaller.
- To order suspended base cabinets and mobile cabinets refer to the catalog section.
- Utility channel will have electrical provisions, see page T5 for details.
- Four electrical receptacles are standard in lower electrical post.
- Overall depth of assembly does not include work surface.
- Optima™ End Panels are not included and must be ordered separately.
- Shipped partially assembled.



**Double Sided Assemblies**



48" wide unit



60", 72" & 96" wide unit

Width	58" Deep	70" Deep
48"	VOA0448	VOA0548
60"	VOA0460	VOA0560
72"	VOA0472	VOA0572
96"	VOA0496	VOA0596

- Available in powder coated steel finish or stainless steel.
- Overall assembly is 84" high, 6" deep rear posts with leveling feet and comes complete with cantilevered table frames. Height adjustable in 1" increments from 29" to 36" (work surface not included).
- Complete with hanging rails to suspend lower cabinets on units 72" wide and smaller.
- To order suspended base cabinets and mobile cabinets refer to the catalog sections (assemblies larger than 72" wide cannot suspend cabinets).
- Utility channel will have electrical provisions, see page T6 for details.
- Four electrical receptacles are standard in lower electrical post.
- Overall depth of assembly does not include work surface.
- Optima™ End Panels are not included and must be ordered separately.
- Shipped partially assembled.



**Note: Double Sided Assembly as shown is not available in the USA.**

*OPTIMA™*  
*2500 SERIES LABORATORY BENCH SYSTEM*

**Single Sided Tech Desk Stations**



48" wide unit



60", 72" & 96" wide unit

Width	32" Deep	38" Deep
48"	VTD0248	VTD0348
60"	VTD0260	VTD0360
72"	VTD0272	VTD0372
96"	VTD0296	VTD0396

- Available in powder coated steel finish or stainless steel.
- Overall assembly is 84" high with 6" deep rear posts with leveling feet.
- Standard 30" high fixed height table (work surface not included). Tech Desk as shown is not intended to be height adjustable.
- Complete with hanging rails to suspend lower cabinets on units 72" wide and smaller.
- To order suspended base cabinets and mobile cabinets refer to the catalog section (assemblies larger than 72" wide cannot suspend cabinets).
- Tech Desk Stations feature double sided linoleum bulletin boards (height of bulletin boards are designed for a 1" thick work surface) and a modesty panel (8-1/8" high). The bulletin board eliminates the use of service fixtures.
- Four electrical receptacles are standard in lower electrical post.
- Utility channel will have electrical provisions, see page T5 for details.
- Optima™ End Panels are not included and must be ordered separately.
- Shipped partially assembled.



**Double Sided Tech Desk Stations**



48" wide unit



60", 72" & 96" wide unit

Width	58" Deep	70" Deep
48"	VTD0448	VTD0548
60"	VTD0460	VTD0560
72"	VTD0472	VTD0572
96"	VTD0496	VTD0596

- Available in powder coated steel finish or stainless steel.
- Overall assembly is 84" high with 6" deep rear posts with leveling feet.
- Standard 30" high fixed height table (work surface not included). Tech Desk as shown is not intended to be height adjustable.
- Complete with hanging rails to suspend lower cabinets on units 72" wide and smaller.
- To order suspended base cabinets and mobile cabinets refer to the catalog section (assemblies larger than 72" wide cannot suspend cabinets).
- Tech Desk Stations feature double sided linoleum bulletin boards (height of bulletin boards are designed for a 1" thick work surface) and a modesty panel (8-1/8" high). The bulletin board eliminates the use of service fixtures.
- Four electrical receptacles are standard in lower electrical post.
- Utility channel will have electrical provisions, see page T6 for details.
- Optima™ End Panels are not included and must be ordered separately.
- Shipped partially assembled.



**Note: Double Sided Assembly as shown is not available in the USA.**

*OPTIMA™*  
*2500 SERIES LABORATORY BENCH SYSTEM*

**Stationary Four Leg Tables**



Width	28" Deep	34" Deep
48"	OTF0248	OTF0448
60"	OTF0260	OTF0460
72"	OTF0272	OTF0472
96"	OTF0296	OTF0496

- Available in powder coated steel finish or stainless steel.
- 2" tubular legs with leveling feet. Height adjustable in 1" increments from 29" to 36" (work surface not included).
- Stationary Table Frame complete with hanging rails to suspend lower cabinets on one side of unit on units 72" wide and smaller.
- To order suspended base cabinets and mobile cabinets refer to the catalog section (assemblies larger than 72" wide cannot suspend cabinets).
- Shipped assembled.

**Two Leg Frames**



Width	26" Deep	32" Deep
48"	VTL0148	VTL0348
60"	VTL0160	VTL0360
72"	VTL0172	VTL0372
96"	VTL0196	VTL0396

- Available in powder coated steel finish or stainless steel.
- Add to Single Sided Assembly to create a Double Sided Assembly.
- 2" tubular legs with leveling feet. Height adjustable in 1" increments from 29" to 36" (work surface not included).
- Complete with hanging rails to suspend lower cabinets on units 72" wide and smaller.
- To order suspended base cabinets and mobile cabinets refer to the catalog section (assemblies larger than 72" wide cannot suspend cabinets).
- Shipped assembled.
- Two Leg Frame is available in the USA as a service part only, for use on a Single Sided Table Assembly.

*OPTIMA™  
2500 SERIES COMPONENTS*

**Upper End Panel**

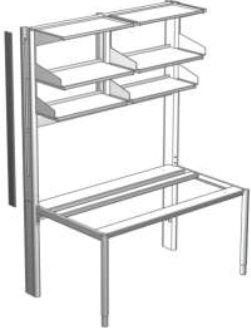

**Item Number**

UPV0000

- Available in powder coated steel finish or stainless steel.
- Upper End Panel used to enclose uncovered ends of Optima™ assembly.
- End panel snaps on for easy installation.

**Lower End Panel**



**Item Number**

LPV0000

- Available in powder coated steel finish or stainless steel.
- Lower End Panel used to enclose uncovered ends of Optima™ assembly.
- End panel snaps on for easy installation.

**Modesty Panels**



Width	Item Number
48"	MPV0148
60"	MPV0160
72"	MPV0172
96"	MPV0196

- Available in powder coated steel finish or stainless steel.
- Mounts to Optima™ post below work top with bracket (hardware included).
- Height is 8-1/8" high.
- Ships not assembled on Optima™.

**Bulletin Boards**



Bulletin Board Option Code	
Single Sided	Double Sided
1B	2B

- The use of a bulletin board eliminates the use of service fixtures.
- Linoleum bulletin boards are double sided and 15" high.
- Mounts to Optima™ posts above work top and below electrical raceway.
- Ships assembled on Optima™.
- See Mott dealer representative for color choices.



*OPTIMA™*  
*2500 SERIES STEEL AND GLASS SHELF COMPONENTS*

**Typical 2500 Series Steel Shelf Assembly**

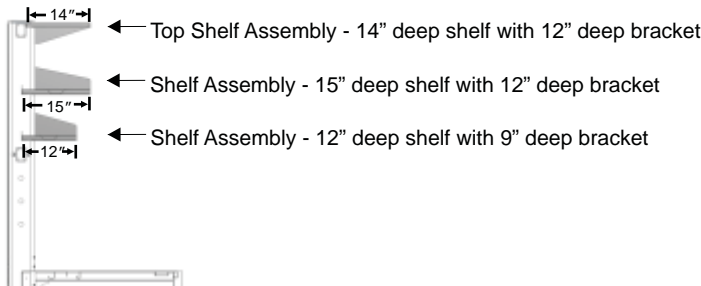

**Top Shelf Assemblies - Steel and Glass**



Width of Bench	Glass Shelf Assembly	Steel Shelf Assembly	Shelf Assemblies Per Side
48"	VSG1448	VSS1448	1
60"	VSG1460	VSS1460	2
72"	VSG1472	VSS1472	2
96"	VSG1496	VSS1496	2

- 48" wide assembly includes one 1" thick shelf, one 14" deep shelf frame and a pair of 12" deep brackets. 60", 72" and 96" wide assemblies includes two 1" thick half width shelves, two 14" deep shelf frames and two pairs of 12" deep brackets. Available in stainless steel.
- 6mm thick laminated safety glass.
- Shelves are adjustable in 1" increments.
- Suitable for Optima™2500 Series only.

**Steel Shelf Assemblies**

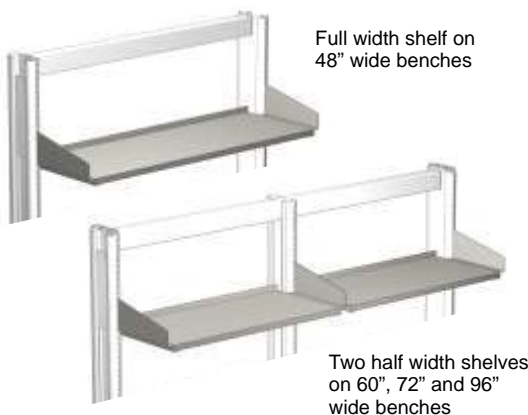

Width of Bench	12" Deep Shelf Assembly	15" Deep Shelf Assembly	Shelf Assemblies Per Side
48"	SAV1248	SAV1548	1
60"	SAV1260	SAV1560	2
72"	SAV1272	SAV1572	2
96"	SAV1296	SAV1596	2

- 48" wide assembly includes one 1" thick shelf, one rear shelf angle, one 12" deep or 15" deep shelf frame and a pair of brackets. 60", 72" and 96" wide assemblies include two 1" thick half width shelves, two rear shelf angles, two 12" deep or 15" deep shelf frames and two pairs of brackets (9" Bracket for 12" deep assembly, 12" bracket for 15" deep assembly). Available in stainless steel.
- Shelves are adjustable in 1" increments.
- Suitable for Optima™2500 Series only.

**Retainer Rods For Shelf Assemblies**



Retainer Rod Option Code	
Powder Coated	Stainless Steel
CR	SR

- 1" high retainer rod (5/16" dia.) prevents articles from falling off the shelf.
- 48" wide benches receive one retainer rod. 60", 72" and 96" benches receive two retainer rods.
- Not suitable for Mott glass shelves.
- Available in stainless steel or powder coated stainless steel.
- Retainer rod ships assembled on the shelf.



*OPTIMA™*  
*2500 SERIES WOOD SHELVING COMPONENTS*

**Typical 2500 Series Wood Shelves**

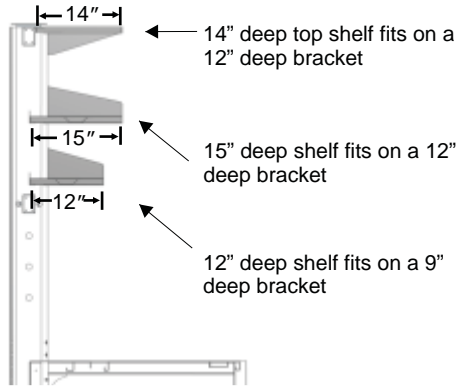

**Wood Shelving Options**

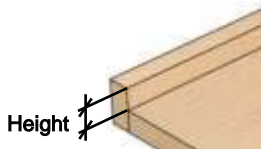

Height	Back Lip	Front Lip	Back & Front Lip
1"	ARW1	AFW1	ABW1
2"	ARW2	AFW2	ABW2
3"	ARW3	AFW3	ABW3
4"	ARW4	AFW4	ABW4

- Height of the lip is measured from the top of the shelf to the top of the lip. Lip is 3/4" thick.
- Shelves are 1" thick.

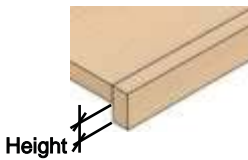

Height	Front Valance
1"	FV1
2"	FV2
3"	FV3
4"	FV4

- Height of the valance is measured from the bottom of the shelf to the bottom of the valance. Valance is 3/4" thick.
- Shelves are 1" thick.

**Wood Shelves for 12" Deep Top Shelf Brackets**



Full width shelf on 48" wide benches



Two half width shelves on 60", 72" and 96" wide benches

Width of Bench	Top shelves for 2500 Series	Shelves Included
48"	VWS1348W	1
60"	VWS1360W	2
72"	VWS1372W	2
96"	VWS1396W	2

- ∞ Shelves are 1" thick.
- ∞ Shelves are suitable for Optima™ 2500 series only.
- ∞ Shelf brackets are not included and must be ordered separately.

**Wood Shelves for 9" Deep and 12" Deep Shelf Brackets**



Full width shelf on 48" wide benches



Two half width shelves on 60", 72" and 96" wide benches

Width of Bench	Shelves for 9" Bracket	Shelves for 12" Bracket	Shelves Included
48"	SAV1248W	SAV1548W	1
60"	SAV1260W	SAV1560W	2
72"	SAV1272W	SAV1572W	2
96"	SAV1296W	SAV1596W	2

- ∞ Shelves are 1" thick.
- ∞ Shelves are suitable for Optima™ 2500 series only.
- ∞ Shelf brackets are not included and must be ordered separately.

**Retainer Rods For Shelf Assemblies**



Retainer Rod Option Code	
Powder Coated	Stainless Steel
CR	SR

- 1" high retainer rod (5/16" dia.) prevents articles from falling off the shelf.
- 48" wide benches receive one retainer rod. 60", 72" and 96" benches receive two retainer rods.
- Not suitable for Mott glass shelves.
- Available in stainless steel or powder coated stainless steel.
- Retainer rod ships assembled on the shelf.

*OPTIMA™*  
*2500 SERIES NON-MOTT SHELF DIMENSIONS*

**Typical Shelf for 12" Top Shelf Bracket**

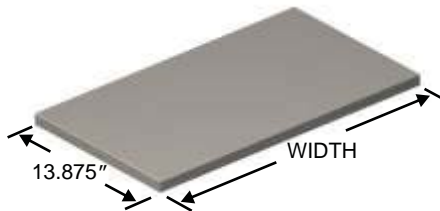

**Shelf dimensions for non-Mott shelves:**

- Quantity of 1 - 43.563" wide shelf is suits a 48" wide Single Sided Assembly
- Quantity of 2 - 26.563" wide shelves suits a 60" wide Single Sided Assembly
- Quantity of 2 - 32.563" wide shelves suits a 72" wide Single Sided Assembly
- Quantity of 2 - 44.563" wide shelves suits a 96" wide Single Sided Assembly

**Typical Shelf for 9" Bracket**

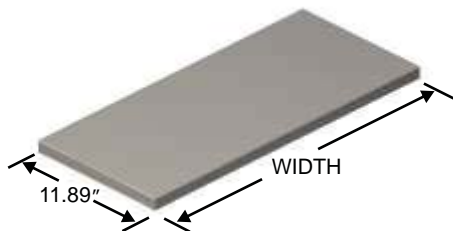

**Shelf dimensions for non-Mott shelves:**

- Quantity of 1 - 43.563" wide shelf is suits a 48" wide Single Sided Assembly
- Quantity of 2 - 26.563" wide shelves suits a 60" wide Single Sided Assembly
- Quantity of 2 - 32.563" wide shelves suits a 72" wide Single Sided Assembly
- Quantity of 2 - 44.563" wide shelves suits a 96" wide Single Sided Assembly

**Typical Shelf for 12" Bracket**

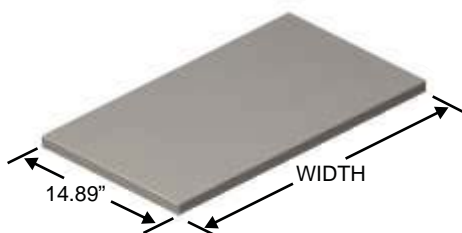

**Shelf dimensions for non-Mott shelves:**

- Quantity of 1 - 43.563" wide shelf is suits a 48" wide Single Sided Assembly
- Quantity of 2 - 26.563" wide shelves suits a 60" wide Single Sided Assembly
- Quantity of 2 - 32.563" wide shelves suits a 72" wide Single Sided Assembly
- Quantity of 2 - 44.563" wide shelves suits a 96" wide Single Sided Assembly

*OPTIMA™*  
*2500 SERIES SHELF COMPONENTS*

**Top Shelf Brackets**



Depth	Item Number
12"	VTB0012

- One pair of 12" powder coated steel end brackets for top shelves. Designed to be used for shelves of different materials, mounts to slotted post. Available in stainless steel.
- Adjustable in 1" increments.
- Suitable for Optima™2500 series only.
- See page T13 for Mott wood shelves. See T14 for non-Mott shelf dimensions.

**Shelf Brackets**



Depth	Item Number
9"	VSB0009
12"	VSB0012

- One pair of powder coated steel end brackets designed to be used for shelves of different materials, mounts to slotted post. Available in stainless steel.
- Adjustable in 1" increments.
- Suitable for Optima™2500 Series only.
- See page T13 for Mott wood shelves. See T14 for non-Mott shelf dimensions.

**Shelf Retainer Rods**



Width of Bench	Powder Coated	Stainless Steel	Retainer Rods Included
48"	PRR0048	SRR0048	1 @ 41"
60"	PRR0060	SRR0060	2 @ 24"
72"	PRR0072	SRR0072	2 @ 30"
96"	PRR0096	SRR0096	2 @ 42"

- 1" high retainer rod (5/16" dia.) Prevents articles from falling off the shelf.
- Retainer rods are measured on centers.
- Can be added to existing Optima™ shelves or shelves of different materials.
- Available in stainless steel or powder coated stainless steel.
- Threaded retainer rod includes hardware for mounting to shelf (shelf must have holes drilled to accept rod).
- Ships loose.

**Shelf Angles**



Width of Bench	Item Number	Shelf Angles Included
48"	ASR2148	1
60"	ASR2160	2
72"	ASR2172	2
96"	ASR2196	2

- Shelf angles can be added to any existing Optima™ shelf and are used to stop items from sliding off of shelving.
- 2" high with a 1" return and notched for shelf brackets. Available in stainless steel.
- Ships loose.

*OPTIMA™*  
*2500 SERIES COMPONENTS*

**Side-To-Side Fastener Kit**

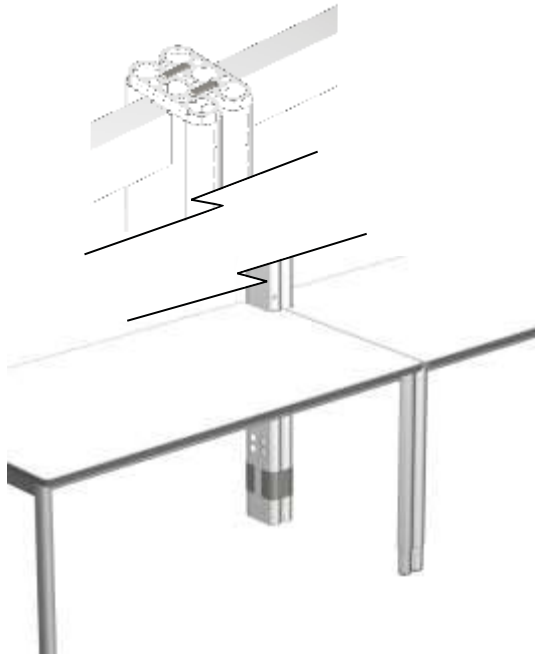

**Item Number**

VSF0000

- Lower bracket attaches to bottom of the rear post legs and the top “U” shaped clips attach to the plumbing quick connect brackets on the top of the rear post legs to stabilize two assemblies that are situated side-to-side.
- Kit available in stainless steel.
- Hardware not included.
- Suitable for Optima™ 2500 Series only.

*OPTIMA™*  
*2100 SERIES LABORATORY BENCH SYSTEM*

**Typical Assemblies**



*OPTIMA™*  
*2100 SERIES LABORATORY BENCH SYSTEM*

**Parts List**

- 1) Optima™ 2100 Series Rear Post Assembly
  - 2) Optima™ 2100 Series Table Assembly
  - 3) Optima™ 2100 Series Upper Cross Member
  - 4) Optima™ 2100 Series Center Post Assembly
  - 5) Optima™ 2100 Series Lower Cross Member
- Note:** Drawing of 60" wide Assembly

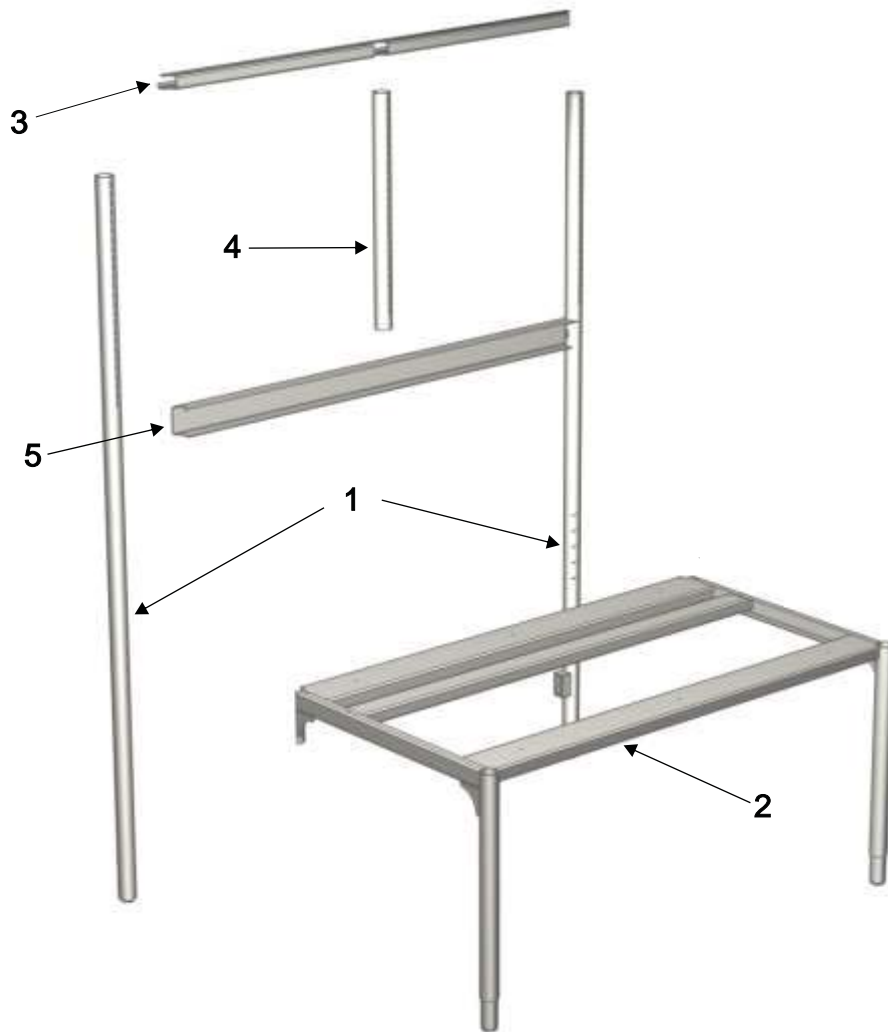

**NOTE:** Please contact Mott Manufacturing for maximum load ratings.

*OPTIMA™*  
*2100 SERIES LABORATORY BENCH SYSTEM*

**Circuit Options**

**WIRING OPTION E**

Option code "1E": 1 CIRCUIT  
48" WIDE ASSEMBLY

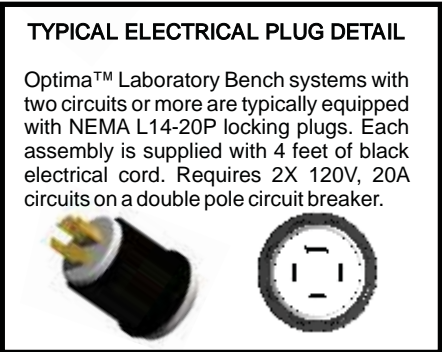
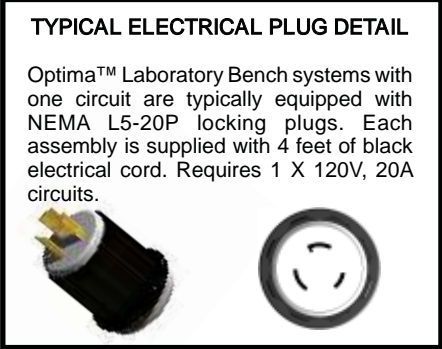
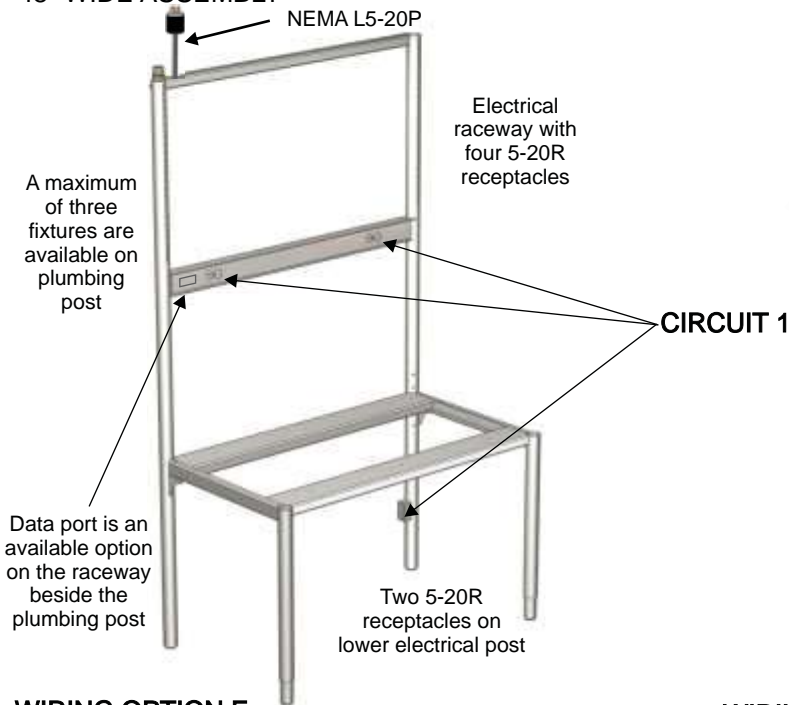

**WIRING OPTION F**

Option code "2E": 1 CIRCUIT  
60", 72" & 96" WIDE ASSEMBLY

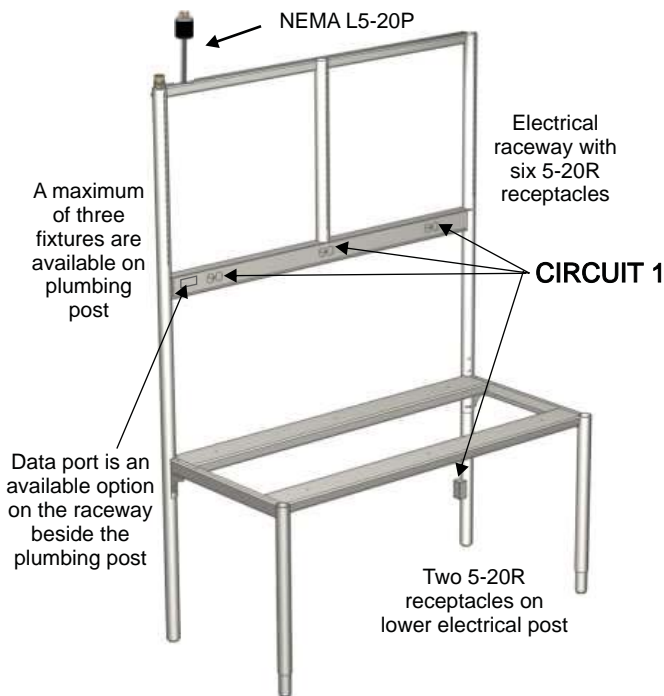

**WIRING OPTION G**

Option code "3E": 2 CIRCUITS  
60", 72" & 96" WIDE ASSEMBLY

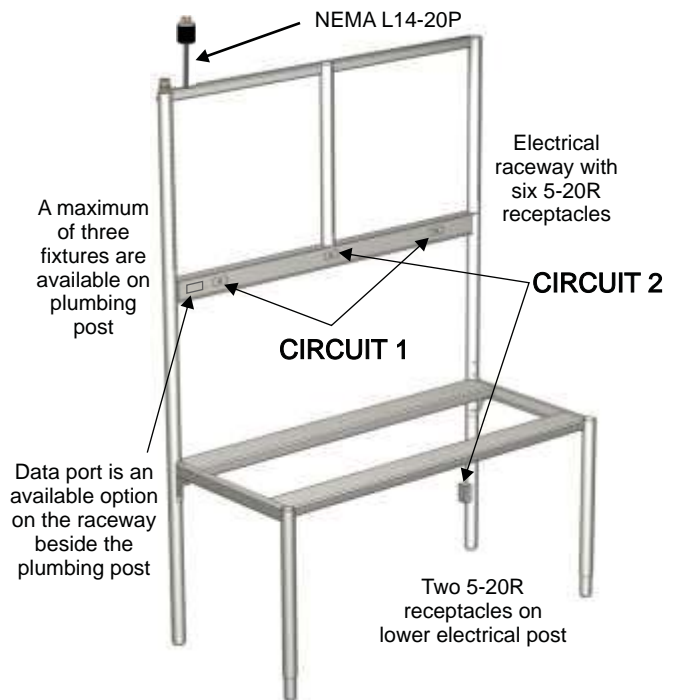



*OPTIMA™*  
*2100 SERIES LABORATORY BENCH SYSTEM*

**Work Surfaces**

Four Leg Table Work Surface for 28" deep or 34" deep units (1" over hang at the front and back).



Four Leg Table Work Surface (1" overhang at front & back)				
Width of Bench	Black Epoxy		Stainless Steel	
	30" Deep	36" Deep	30" Deep	36" Deep
48"	EOP3048	EOP3648	SOP3048	SOP3648
60"	EOP3060	EOP3660	SOP3060	SOP3660
72"	EOP3072	EOP3672	SOP3072	SOP3672
96"	EOP3096	EOP3696	SOP3096	SOP3696

- Stainless steel work surfaces are type 304-4, flat, square edges, stainless steel hat channel construction, 1" thick.
- Epoxy work surfaces are 1" thick.

2100 Series Work Surface for 29" deep and 35" deep units (1" overhang at front).

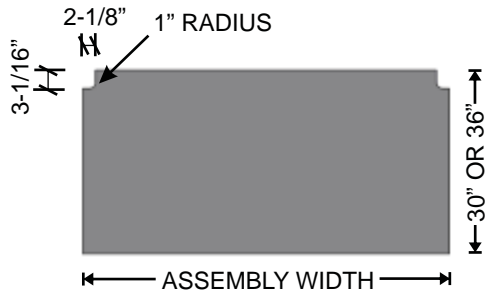

2100 Series Assembly Work Surface (1" overhang at front)				
Width of Bench	Black Epoxy		Stainless Steel	
	30" Deep	36" Deep	30" Deep	36" Deep
48"	ERS3048	ERS3648	SRS3048	SRS3648
60"	ERS3060	ERS3660	SRS3060	SRS3660
72"	ERS3072	ERS3672	SRS3072	SRS3672
96"	ERS3096	ERS3696	SRS3096	SRS3696

- Stainless steel work surfaces are type 304-4, flat, square edges, stainless steel hat channel construction, 1" thick.
- Epoxy work surfaces are 1" thick.

*OPTIMA™*  
*2100 SERIES LABORATORY BENCH SYSTEM*

**Optima™ 2100 Series Assembly**



48" wide unit



60", 72" & 96" wide unit

Width	29" Deep	35" Deep
48"	ROA0248	ROA0348
60"	ROA0260	ROA0360
72"	ROA0272	ROA0372
96"	ROA0296	ROA0396

- Available in powder coated steel finish or stainless steel.
- Overall assembly is 84" high, 2" tubular rear posts with leveling feet and comes complete with cantilevered table frame. Height adjustable in 1" increments from 29" to 36" (work surface not included).
- Complete with hanging rails to suspend lower cabinets on units 72" wide and smaller.
- To order suspended base cabinets and mobile cabinets refer to the catalog section (assemblies larger than 72" wide cannot suspend cabinets).
- Utility channel will have electrical provisions, see page S17 for details.
- Two electrical receptacles are standard in lower electrical post.
- Overall depth of assembly does not include work surface.
- Shipped partially assembled.



**Tech Desk Station**



48" wide unit



60", 72" & 96" wide unit

Width	29" Deep	35" Deep
48"	RTD0248	RTD0348
60"	RTD0260	RTD0360
72"	RTD0272	RTD0372
96"	RTD0296	RTD0396

- Available in powder coated steel finish or stainless steel.
- Overall assembly is 84" high with 2" tubular rear posts with leveling feet.
- Standard 30" high fixed height table (work surface not included). Tech Desk as shown is not intended to be height adjustable.
- Complete with hanging rails to suspend lower cabinets on units 72" wide and smaller.
- To order suspended base cabinets and mobile cabinets refer to the catalog section (assemblies larger than 72" wide cannot suspend cabinets).
- Tech Desk Stations feature a single sided linoleum bulletin board (height of bulletin board is designed for a 1" thick work surface) and a modesty panel (13-3/4" high). The bulletin board eliminates the use of service fixtures.
- Two electrical receptacles are standard in lower electrical post.
- Utility channel will have electrical provisions, see page S17 for details.
- Shipped partially assembled.



*OPTIMA™*  
*2100 SERIES LABORATORY BENCH SYSTEM*

**Four Leg Tables**



Width	28" Deep	34" Deep
48"	OTF0248	OTF0448
60"	OTF0260	OTF0460
72"	OTF0272	OTF0472
96"	OTF0296	OTF0496

- Available in powder coated steel finish or stainless steel.
- 2" tubular legs with leveling feet. Height adjustable in 1" increments from 29" to 36" (work surface not included).
- To order suspended base cabinets and mobile cabinets refer to the catalog section (assemblies larger than 72" wide cannot suspend cabinets).
- Table Frame complete with hanging rails to suspend lower cabinets on one side on units 72" wide and smaller.
- Shipped assembled.

**Modesty Panels**



Width	Item Number
48"	MPR0148
60"	MPR0160
72"	MPR0172
96"	MPR0196

- Available in powder coated steel finish or stainless steel.
- Mounts to Optima™ post below work top with bracket (hardware included).
- Height is 13-3/4" high.
- Ships not assembled on Optima™.

**Bulletin Board**

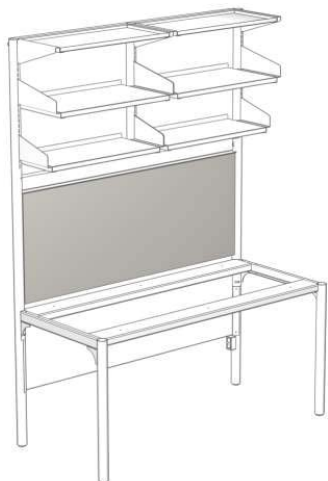

Option Code
1B

- The use of a bulletin board eliminates the use of service fixtures.
- Linoleum bulletin boards are single sided and 17" high, except 96" wide assemblies receive 15" high bulletin boards.
- Mounts to Optima™ posts above work top and below electrical raceway.
- Ships assembled on Optima™.

*OPTIMA™*  
*2100 SERIES STEEL AND GLASS SHELF COMPONENTS*

**Typical 2100 Series Steel Shelf Assembly**

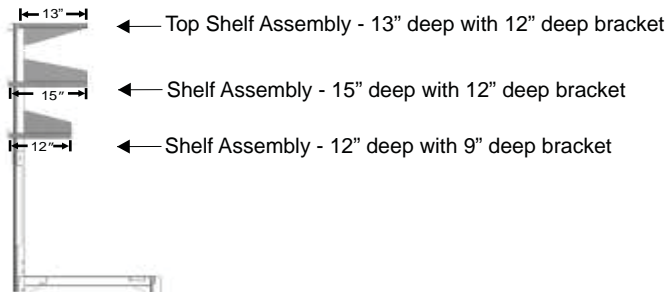

**Top Shelf Assemblies - Steel and Glass**



Width of Bench	Glass Shelf Assembly	Steel Shelf Assembly	Shelf Assemblies Included
48"	RSG1348	RSS1348	1
60"	RSG1360	RSS1360	2
72"	RSG1372	RSS1372	2
96"	RSG1396	RSS1396	2

- 48" wide assembly includes one 1" thick shelf, one 13" deep shelf frame and a pair of 12" deep brackets. 60", 72" and 96" wide assemblies include two 1" thick half width shelves, two 13" deep shelf frames and two pairs of 12" deep brackets. Available in stainless steel.
- 6mm thick laminated safety glass.
- Shelves are adjustable in 1" increments.
- Suitable for Optima™2100 Series only.
- All dimensions are nominal.

**Steel Shelf Assemblies**

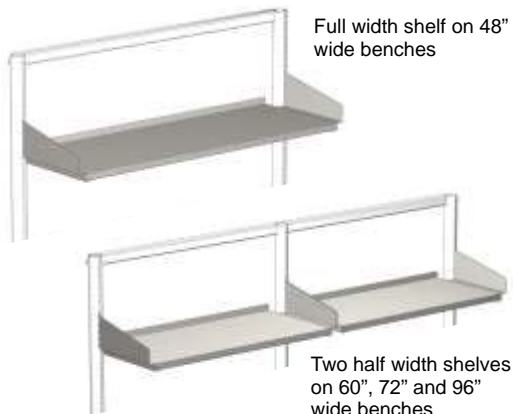

Width of Bench	12" Deep Shelf Assembly	15" Deep Shelf Assembly	Shelf Assemblies Included
48"	SAR1248	SAR1548	1
60"	SAR1260	SAR1560	2
72"	SAR1272	SAR1572	2
96"	SAR1296	SAR1596	2

- 48" wide assembly includes one 1" thick shelf, one rear shelf angle, one 12" deep or 15" deep shelf frame and a pair of brackets. 60", 72" and 96" wide assemblies include two 1" thick half width shelves, two rear shelf angles, two 12" deep or 15" deep shelf frames and two pairs of brackets. (9" Bracket for 12" deep assembly, 12" bracket for 15" deep assembly). Available in stainless steel.
- Shelves are adjustable in 1" increments.
- Suitable for Optima™2100 Series only.
- All dimensions are nominal.

**Retainer Rod For Shelf Assemblies**



Retainer Rod Option Code	
Powder Coated	Stainless Steel
CR	SR

- 1" high retainer rod (5/16" dia.) prevents articles from falling off the shelf.
- 48" wide benches receive one retainer rod. 60", 72" and 96" benches receive two retainer rods.
- Not suitable for Mott glass shelves.
- Available in stainless steel or powder coated stainless steel.
- Retainer rod ships assembled on the shelf.

*OPTIMA™*  
*2100 SERIES WOOD SHELVING COMPONENTS*

**Typical 2100 Series Wood Shelves**

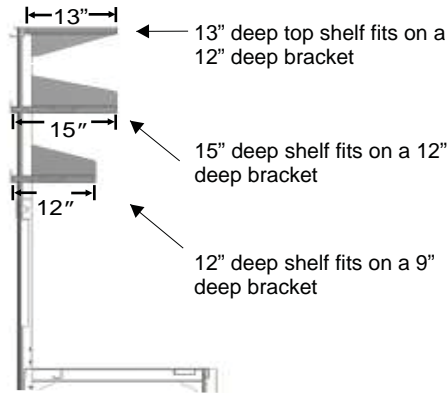

**Wood Shelving Options**

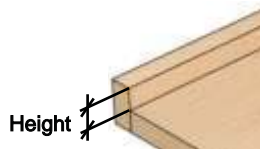

Height	Back Lip	Front Lip	Back & Front Lip
1"	ARW1	AFW1	ABW1
2"	ARW2	AFW2	ABW2
3"	ARW3	AFW3	ABW3
4"	ARW4	AFW4	ABW4

- Height of the lip is measured from the top of the shelf to the top of the lip. Lip is 3/4" thick.
- Shelves are 1" thick.

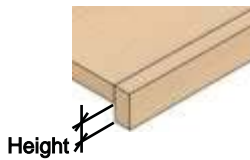

Height	Front Valance
1"	FV1
2"	FV2
3"	FV3
4"	FV4

- Height of the valance is measured from the bottom of the shelf to the bottom of the valance. Valance is 3/4" thick.
- Shelves are 1" thick.

**Wood Shelves for 12" Deep Top Shelf Brackets**



Full width shelf on 48" wide benches



Two half width shelves on 60", 72" and 96" wide benches

Width of Bench	Top shelves for 2100 Series	Shelves Included
48"	RSW1348W	1
60"	RSW1360W	2
72"	RSW1372W	2
96"	RSW1390W	2

- ∞ Shelves are 1" thick.
- ∞ Shelves are suitable for Optima™ 2100 series only.
- ∞ Shelf brackets are not included and must be ordered separately.

**Wood Shelves for 9" Deep and 12" Deep Shelf Brackets**



Full width shelf on 48" wide benches



Two half width shelves on 60", 72" and 96" wide benches

Width of Bench	Shelves for 9" Bracket	Shelves for 12" Bracket	Shelves Included
48"	SAW1248W	SAW1548W	1
60"	SAW1260W	SAW1560W	2
72"	SAW1272W	SAW1572W	2
96"	SAW1296W	SAW1596W	2

- ∞ Shelves are 1" thick.
- ∞ Shelves are suitable for Optima™ 2100 series only.
- ∞ Shelf brackets are not included and must be ordered separately.

**Retainer Rods For Shelf Assemblies**

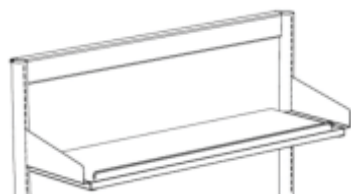

Retainer Rod Option Code	
Powder Coated	Stainless Steel
CR	SR

- 1" high retainer rod (5/16" dia.) prevents articles from falling off the shelf.
- 48" wide benches receive one retainer rod. 60", 72" and 96" benches receive two retainer rods.
- Not suitable for Mott glass shelves.
- Available in stainless steel or powder coated stainless steel.
- Retainer rod ships assembled on the shelf.

*OPTIMA™*  
*2100 SERIES NON-MOTT SHELF DIMENSIONS*

**Typical Shelf for 12" Top Shelf Bracket**

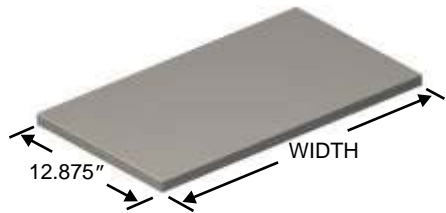

**Shelf dimensions for non-Mott shelves:**

- Quantity of 1 - 43.563" wide shelf is suits a 48" wide Single Sided Assembly
- Quantity of 2 - 26.563" wide shelves suits a 60" wide Single Sided Assembly
- Quantity of 2 - 32.563" wide shelves suits a 72" wide Single Sided Assembly
- Quantity of 2 - 44.563" wide shelves suits a 96" wide Single Sided Assembly

**Typical Shelf for 9" Bracket**

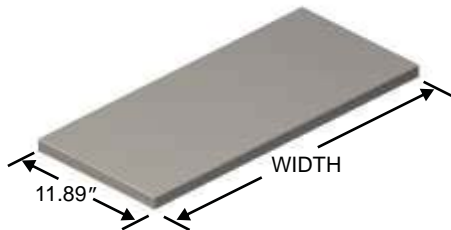

**Shelf dimensions for non-Mott shelves:**

- Quantity of 1 - 43.563" wide shelf is suits a 48" wide Single Sided Assembly
- Quantity of 2 - 26.563" wide shelves suits a 60" wide Single Sided Assembly
- Quantity of 2 - 32.563" wide shelves suits a 72" wide Single Sided Assembly
- Quantity of 2 - 44.563" wide shelves suits a 96" wide Single Sided Assembly

**Typical Shelf for 12" Bracket**

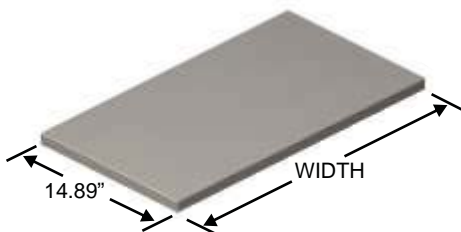

**Shelf dimensions for non-Mott shelves:**

- Quantity of 1 - 43.563" wide shelf is suits a 48" wide Single Sided Assembly
- Quantity of 2 - 26.563" wide shelves suits a 60" wide Single Sided Assembly
- Quantity of 2 - 32.563" wide shelves suits a 72" wide Single Sided Assembly
- Quantity of 2 - 44.563" wide shelves suits a 96" wide Single Sided Assembly

*OPTIMA™*  
*2100 SERIES COMPONENTS*

**Back-To-Back Fastener Kit**



**Item Number**

RBF0000

- Lower bracket attaches to bottom of the rear post legs to stabilize two assemblies that are situated back-to-back.
- Fastener available in stainless steel.
- Hardware not included.
- Suitable for Optima™ 2100 Series only.

**Side-To-Side Fastener**



**Item Number**

RSF0000

- The bracket attaches to the front or rear post legs to stabilize two assemblies that are situated side-to-side.
- Fastener available in stainless steel.
- Hardware not included.
- Suitable for Optima™ 2100 Series only.

Note: Side-To-Side Fasteners as shown from behind the Optima™ 2100 Series assembly.



*OPTIMA™*  
*2100 SERIES SHELF COMPONENTS*

**Top Shelf Brackets**



Depth	Item Number
12"	RTB0012

- One pair of 12" powder coated steel end brackets for top shelves. Designed to be used for shelves of different materials, mounts to slotted post. Available in stainless steel.
- Adjustable in 1" increments.
- Suitable for Optima™2100 series only.
- See page T24 for Mott wood shelves. See page T25 for non-Mott shelf dimensions.

**Shelf Brackets**



Depth	Item Number
9"	RSB0009
12"	RSB0012

- One pair of powder coated steel end brackets designed to be used for shelves of different materials, mounts to slotted post. Available in stainless steel.
- Adjustable in 1" increments.
- Suitable for Optima™2100 Series only.
- See page T24 for Mott wood shelves. See page T25 for non-Mott shelf dimensions.

**Shelf Retainer Rods**



Width of Bench	Powder Coated	Stainless Steel	Retainer Rods Included
48"	PRR0048	SRR0048	1
60"	PRR0060	SRR0060	2
72"	PRR0072	SRR0072	2
96"	PRR0096	SRR0096	2

- 1" high retainer rod (5/16" dia.) prevents articles from falling off the shelf.
- Can be added to existing Optima™ shelves or shelves of different materials (Width of retainer rod is based on shelf width, dimensions are nominal).
- Available in stainless steel or powder coated stainless steel.
- Threaded retainer rod includes hardware for mounting to shelf (shelf must have holes drilled to accept rod).

**Steel Shelf Angles**



Width of Bench	Item Number	Shelf Angles Included
48"	ASR2148	1
60"	ASR2160	2
72"	ASR2172	2
96"	ASR2196	2

- Steel Shelf angles can be added to any existing Optima™ shelf and are used to stop items from sliding off of shelving.
- 2" high with a 1" return and notched for shelf brackets. Available in stainless steel.
- Dimensions are nominal.
- Ships loose.

*OPTIMA™  
COMPONENTS*

**Under Mount Shelf Task Lights**

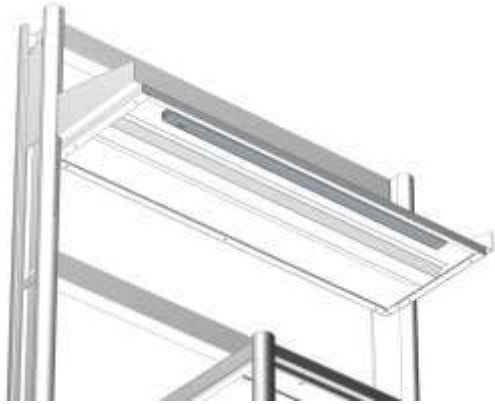

Note: Shown on Optima™ 2500 Series

Length of Light	Item Number
14"	TLW0014
23"	TLW0023
36"	TLW0036
48"	TLW0048
59"	TLW0059

- Order light a minimum 6" shorter than the shelf. For shelf dimensions refer to page T14 for 2500 series and T25 for 2100 series.
- Low profile (.98" wide by 1.65" high) T5 white fluorescent task light mounts to underside of the shelf.
- Task light to be plugged into the Optima™ raceway.
- Shatterproof polycarbonate lens protects the lamp.
- Easily linkable in one continuous line using Flexible Connectors. 12" Flexible Connector and 6' power plug comes standard with each light. See below to order longer Flexible Connectors.
- On-off rocker switch located on the side of the fixture.
- 8000 hour, cool white replaceable T5 lamp included.
- UL listed.
- Ships loose, includes Mott's mounting brackets.

**Task Light Flexible Connectors**



Width	Item Number
12"	LFC0012
24"	LFC0024
36"	LFC0036

- Flexible Connector allows to easily link T5 fluorescent lights in one continuous line.

**LCD Monitor Arms**

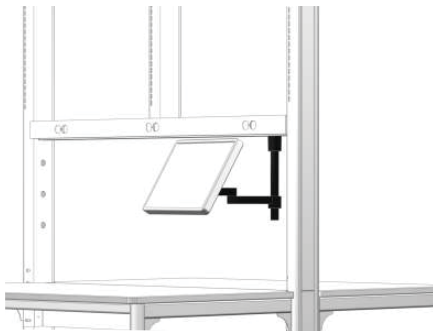

Item Number	
Anodized Silver Finish	Black Finish
MONARMS	MONARMB

- Position your LCD for maximum productivity and comfort.
- Features foldable arms which adjust vertically up and down a 12" pole. The arms can fold up to fit in about 3" of space and extend out 14". Rotates 360 degrees at three joints, monitor tilting mechanism can tilt over 200 degrees and adjustable tension at joints which is ideal for touch-screen applications.
- Weight capacity adjusts to hold up to 40lbs (Monitor depth greater than 2" may diminish capacity). Monitor not included.
- Easily attaches to LCDs that are VESA MIS-D, 100/75, compliant.
- Ships loose. Installs easily to lower cross member with one screw.
- The use of a monitor arm prevents usage of a bulletin board.

**Hanging CPU Holder**

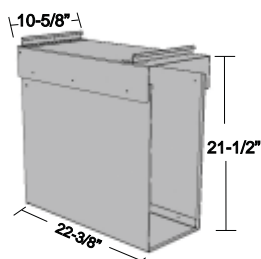

Item Number
CPU1010

- Suspends from Optima™ system with hanging rails and is supplied with full extension runners to slide out CPU unit.
- Inside dimension of CPU holder is 9-3/16".

*OPTIMA™*  
*COMPONENTS*

**Ceiling Service Panels**

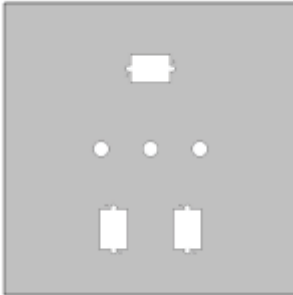

**Item Number**

OSP0001

- Powder coated steel panel takes the place of a standard ceiling tile.
- Offers the ability to mount and disconnect quick connect service fixtures, electrical and data outlets.
- Dimension 23-3/4" x 23-3/4".
- 3 service access holes and 3 electrical cutouts.
- Panel is compatible with most T grid acoustical suspended ceiling structures.
- Fixtures must be ordered separately.

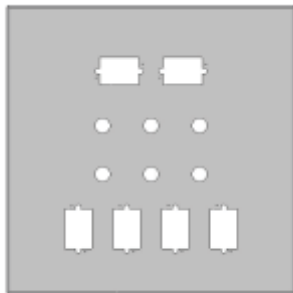

**Item Number**

OSP0002

- Powder coated steel panel takes the place of a standard ceiling tile.
- Offers the ability to mount and disconnect quick connect service fixtures, electrical and data outlets.
- Dimension 23-3/4" x 23-3/4".
- 6 service access holes and 6 electrical cutouts.
- Panel is compatible with most T grid acoustical suspended ceiling structures.
- Fixtures must be ordered separately.

Standard Optima™ Laboratory Bench systems are UL962 Listed, however this listing does not cover plumbing fixtures and associated piping. The customer is responsible for ensuring that internal piping and components meet local codes and standards. In some jurisdictions on-site inspection and testing may be required, this service is not provided by Mott Manufacturing.

### OPTIMA™

**SERVICE FIXTURES** - These parts are to be ordered if you require services to be shipped loose.

#### Female Quick Connect Fittings



For Coiled & PVC Hose		
Service	Band Color	Item Number
AIR	Orange	MCPVAIR
ARG	Violet	MCPVARG
CW	Green	MCPVCWT
GAS	Blue	MCPVGAS
HE	Black	MCPVHEL
NIT	Brown	MCPVNIT
VAC	Yellow	MCPVVAC

- These parts are to be ordered if you require services to be shipped loose.
- A panel mounted brass keyed quick connect plug is suitable for panel mounting on overhead service carriers and Ceiling Service Panels with coiled and PVC hoses.
- Complete with a 3/8" male NPT inlet.
- Only plug and body quick connects of the same color will couple and allow flow.

#### Coiled & PVC Hose Assemblies

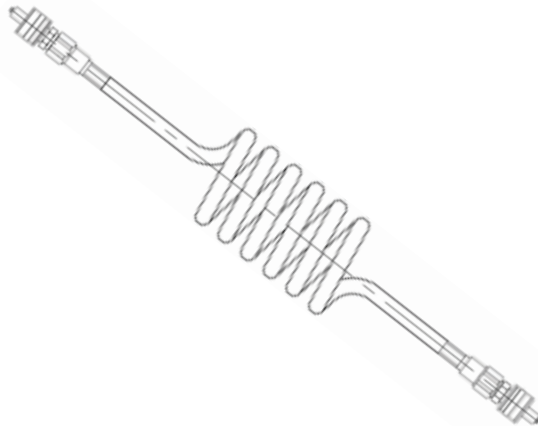

Coiled Hose		
Service	Band Color	Item Number
AIR	Orange	COHAIR
ARG	Violet	COHAARG
CW	Green	COHACWT
GAS	Blue	COHAGAS
HE	Black	COHAHEL
NIT	Brown	COHANIT
VAC	Yellow	COHAVAC

- These parts are to be ordered if you require services to be shipped loose.
- Assembly complete with 3/8" I.D. X 9/16" O.D. Coiled polyurathane hose (color of hose is translucent blue) and keyed plug quick connects.
- Suitable for all Optima™ series.
- Only plug and body quick connects of the same color will couple and allow flow.

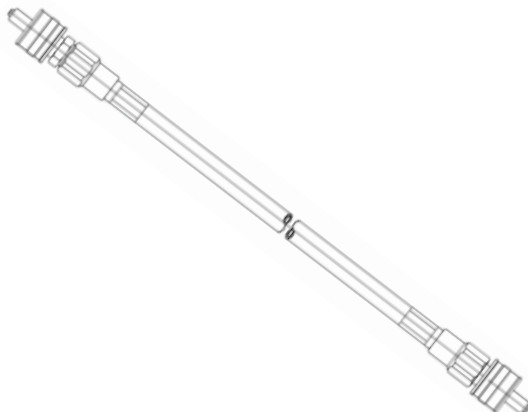

PVC Hose		
Service	Band Color	Item Number
AIR	Orange	PVHAIR
ARG	Violet	PVHAARG
CW	Green	PVHACWT
GAS	Blue	PVHAGAS
HE	Black	PVHAHEL
NIT	Brown	PVHANIT
VAC	Yellow	PVHAVAC

- These parts are to be ordered if you require services to be shipped loose.
- Assembly complete with 3/8" I.D. X 72" long reinforced PVC hose color-coded per service and keyed plug quick connects.
- Suitable for Optima™ series.
- Only plug and body quick connects of the same color will couple and allow flow.

**Note:** The above hoses may not be acceptable for use with Natural Gas in some jurisdictions. Please consult with the local authorities before ordering. Consult Mott for further information.

Standard Optima™ Laboratory Bench systems are UL962 Listed, however this listing does not cover plumbing fixtures and associated piping. The customer is responsible for ensuring that internal piping and components meet local codes and standards. In some jurisdictions on-site inspection and testing may be required, this service is not provided by Mott Manufacturing.

**OPTIMA™**

**SERVICE FIXTURES** - These parts are to be ordered if you require services to be shipped loose.

**Female Quick Connect Fittings**

For Stainless Steel Hose		
Service	Band Color	Item Number
AIR	Orange	MSSAAIR
ARG	Violet	MSSAARG
CW	Green	MSSACWT
GAS	Blue	MSSAGAS
HE	Black	MSSAHEL
NIT	Brown	MSSANIT
VAC	Yellow	MSSAVAC

- These parts are to be ordered if you require services to be shipped loose.
- A panel mounted stainless steel keyed quick connect plug is suitable for panel mounting on overhead service carriers and Ceiling Service Panels with stainless steel hoses.
- Complete with 3/8" NPT inlet.
- Only plug and body quick connects of the same color will couple and allow flow.

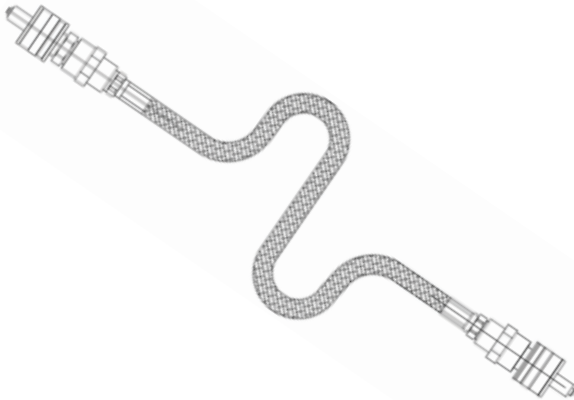
**Stainless Steel Hose Assemblies**

Stainless Steel Hose		
Service	Band Color	Item Number
AIR	Orange	SSHAIR
ARG	Violet	SSHAARG
CW	Green	SSHACWT
GAS	Blue	SSHAGAS
HE	Black	SSHAHEL
NIT	Brown	SSHANIT
VAC	Yellow	SSHAVAC

- These parts are to be ordered if you require services to be shipped loose.
- Assembly complete with 3/8" I.D. X 72" long stainless steel braided hose (hose has Teflon core) and stainless steel keyed plug quick connects.
- Corrugated gas appliance connector is supplied for natural gas.
- Suitable for Optima™ series.
- Only plug and body quick connects of the same color will couple and allow flow.

**Note:** The above hoses may not be acceptable for use with Natural Gas in some jurisdictions. Please consult with the local authorities before ordering. Consult Mott for further information.

## OPTIMA™

**SERVICE FIXTURES** - These parts are to be ordered if you require services to be shipped loose.

### Quick Connect Valve Assemblies

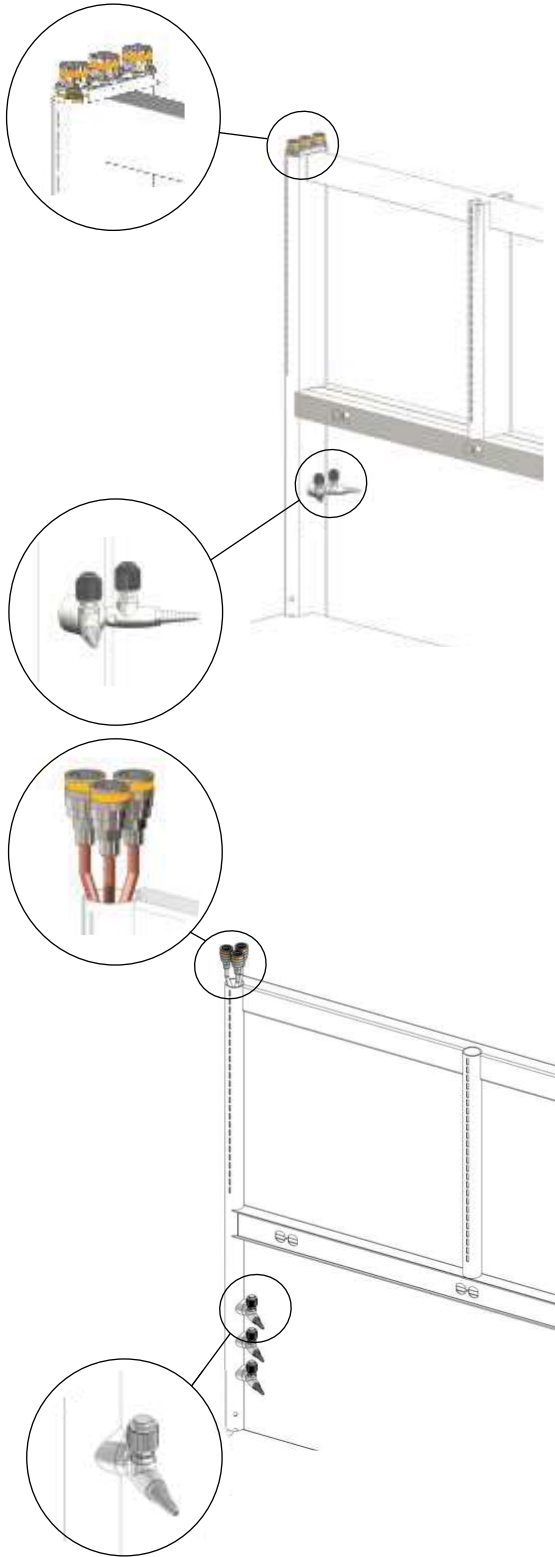

## LABORATORY

## FURNITURE

Standard Optima™ Laboratory Bench systems are UL962 Listed, however this listing does not cover plumbing fixtures and associated piping. The customer is responsible for ensuring that internal piping and components meet local codes and standards. In some jurisdictions on-site inspection and testing may be required, this service is not provided by Mott Manufacturing.

### For 2500 Series

Service	Band Color	For Coiled & PVC Hose	For Stainless Hose
AIR	Orange	QCV1AIR	QCV3AIR
ARG	Violet	QCV1ARG	QCV3ARG
CW *	Green	QCV1CWT	QCV3CWT
GAS	Blue	-	QCV3GAS
HE	Black	QCV1HEL	QCV3HEL
NIT	Brown	QCV1NIT	QCV3NIT
VAC	Yellow	QCV1VAC	QCV3VAC

- These parts are to be ordered if you require services to be shipped loose.
- Assembly complete with panel mounted wye service fixture (Instrumentation Needle Valve supplied, Note: \* Cold Water is supplied with ball valve), keyed quick connect body and tubing. Hoses are not included and must be ordered separately. (When ordering assembly for Coiled & PVC hose, brass keyed quick connect body and copper tubing is supplied. When ordering assembly for stainless steel hose, stainless steel keyed quick connect body and stainless steel tubing is supplied.)
- Corrugated gas appliance connector is supplied for natural gas.
- This assembly is only suitable for Optima™ 2500 Series and double sided Optima™ Mobile Workstation.
- Only plug and body quick connects of the same color will couple and allow flow.

### For 2100 Series

Service	Band Color	For Coiled & PVC Hose	For Stainless Hose
AIR	Orange	QCV2AIR	QCV4AIR
ARG	Violet	QCV2ARG	QCV4ARG
CW *	Green	QCV2CWT	QCV4CWT
GAS	Blue	-	QCV4GAS
HE	Black	QCV2HEL	QCV4HEL
NIT	Brown	QCV2NIT	QCV4NIT
VAC	Yellow	QCV2VAC	QCV4VAC

- These parts are to be ordered if you require services to be shipped loose.
- Assembly complete with panel mounted single service fixture (Instrumentation Needle Valve supplied, Note: \* Cold Water is supplied with ball valve), keyed quick connect body and tubing. Hoses are not included and must be ordered separately. (When ordering assembly for Coiled & PVC hose, brass keyed quick connect body and copper tubing is supplied. When ordering assembly for stainless steel hose, stainless steel keyed quick connect body and stainless steel tubing is supplied.)
- Corrugated gas appliance connector is supplied for natural gas.
- This assembly is only suitable for Optima™ 2100 Series and single sided Optima™ Mobile Workstation.
- Only plug and body quick connects of the same color will couple and allow flow.

*SIGMA FUSION™*  
*ADAPTABLE LABORATORY FURNITURE SOLUTIONS*

**The Solution to Change...**

The objective to a winning laboratory design is to create the ideal workplace for today, while incorporating adaptability to respond to the changes of the future. Sigma Fusion™ system represents a new balance of adaptability and design.

Sigma Fusion™ incorporates a slim line core assembly with cantilevered work surfaces that allows height adjustment for individual workstations to meet the requirements of a large variety of users, equipment, and processes.

An integrated raised distribution system provides quick and easy access to services while providing superior flexibility by keeping the work surface open to accommodate equipment and procedures.

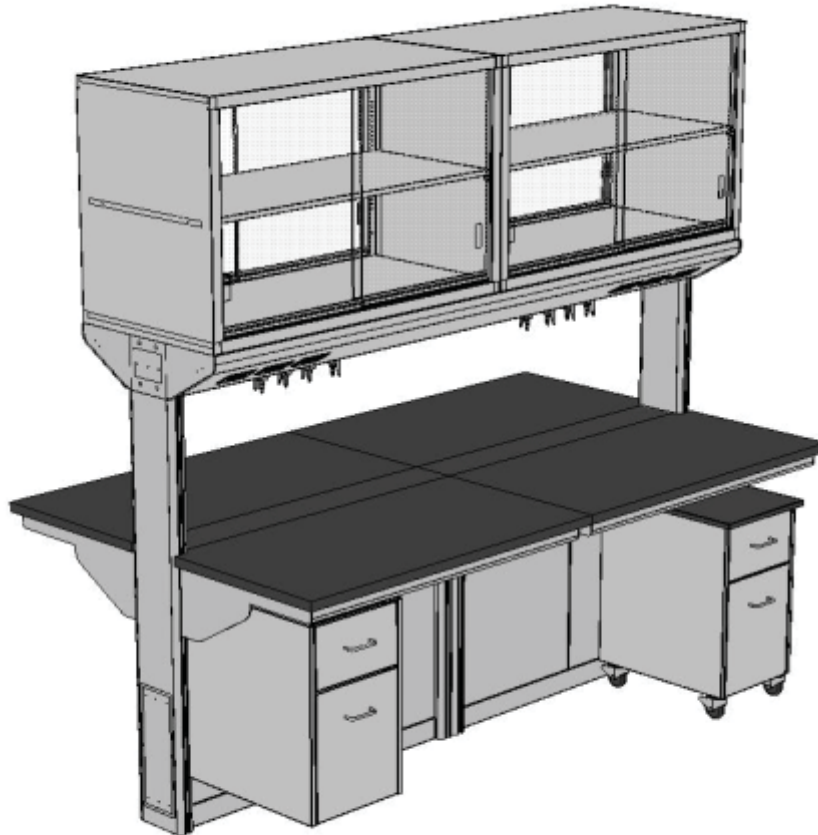

**For additional information and help in planning contact Mott Manufacturing.**



*SIGMA FUSION™*  
*FLEXIBLE LABORATORY SYSTEMS*

**Modular Support Structure Design**

Each core system is fabricated from prime quality furniture grade cold rolled steel.

Support systems are a core and panel style support structure.

Core structures must be anchored to suitable floors.

Modular components are suitable for island configurations.

Core assemblies have removable panels on front and back sides with access panels on both ends.

**Modular Support Structure Features**

Core systems support work surfaces, under counter suspended cabinets and overhead storage components.

The core system allows plumbing, electrical and other services to be installed using commonly available mounting systems.

Suspended cabinets can be supported using hook shaped rails attached near the front and rear of the cantilevered work surface. Cabinets can be added at any time and it is possible to remove and relocate a fully loaded cabinet to any position between legs without disturbing the counter top.

Cover panels can be fastened with a positive friction catch which snaps into place. The panel does not require adhesives to be attached. Panels are half width and it is possible to remove panels without removing suspended cabinets.

Overhead storage cabinets are mounted above the raised distribution system.

The vertical height of table work surfaces can be adjusted in 1" increments without the use of special tools.

**Material Gauges**

- |                           |                                      |
|---------------------------|--------------------------------------|
| • Fusion™ Post            | 16 gauge with Sigma Barrier™ coating |
| • Fusion™ Post Panel      | 20 gauge                             |
| • Fusion™ Core Base       | 18 gauge                             |
| • Fusion™ Interior Core   | 16 gauge                             |
| • Fusion™ Cover Panel     | 18 gauge                             |
| • Fusion™ Carrier End Cap | 11 gauge                             |

*SIGMA FUSION™  
FLEXIBLE LABORATORY SYSTEMS*

**Parts List**

- 1) Fusion Post (Sigma Barrier™ coating and powder coated), complete with levelers
  - 2) Fusion Counter Support
  - 3) Fusion Core Base
  - 4) Fusion Post (Sigma Barrier™ coating and Powder coated), complete with levelers
  - 5) Fusion Overhead Service Carrier Assembly
  - 6) Fusion Cover Panel
  - 7) Fusion Interior Core (Sigma Barrier™ coating and Powder coated)
  - 8) Fusion Post Panel
  - 9) Fusion Carrier End Cap
- Note: Drawing of Island Single Core Assembly

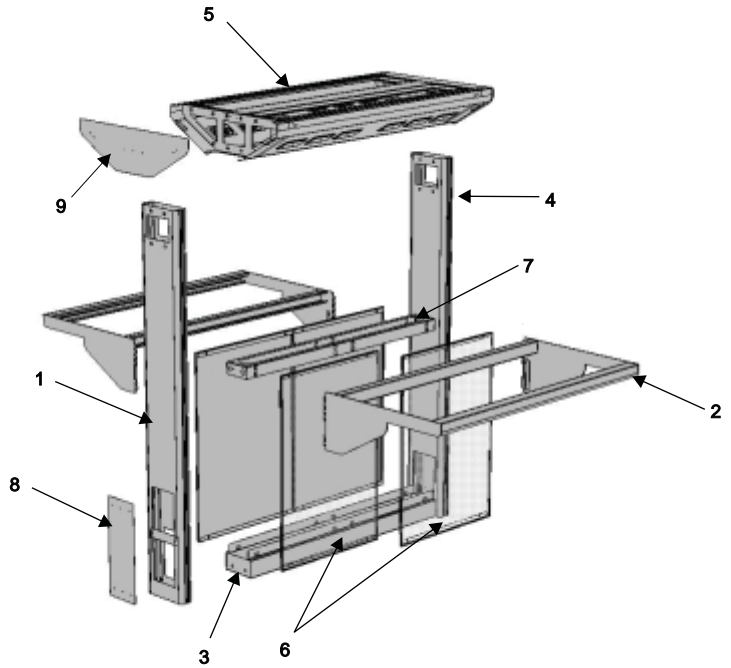

**Load Ratings**

**Load Maximums**

Maximum load ratings are live loads and include loads applied to top of work surface, including total weight of work surface, suspended cabinetry and other accessories. These capacities should be used as guidelines only. Please contact Mott Manufacturing for specific load requirements. Maximum load ratings are based on the load being evenly balanced on both sides. Individual component or assembly load ratings should not be exceeded for any surface.

**Maximum Load Ratings**

**Modular Support Structure**

- Top of Core 180lbs
- Cantilevered Work surface 400lbs

**Cabinets**

- Suspended Base Cabinets 300lbs
- Upper Cabinets 300lbs

**Total Island Core Assembly**

- Island Core 1760lbs

Includes two work surfaces at 400lbs each, and any combination of suspended base cabinets and upper cabinets (at their rated loads). Loads must be balanced both sides.

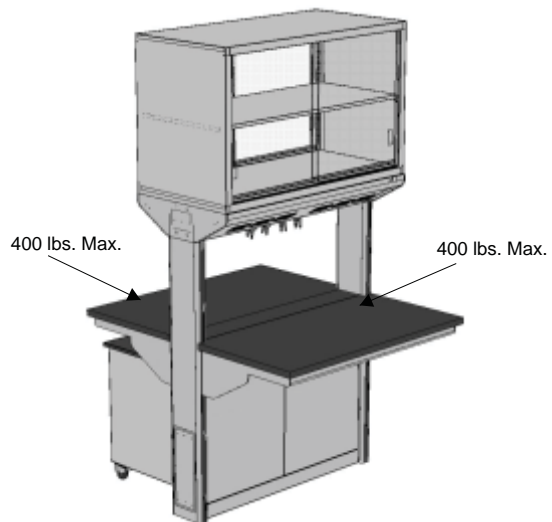

Island Single Core Assembly

*SIGMA FUSION™*  
*RAISED DISTRIBUTION SYSTEM*

**About the Raised Distribution System**

The raised distribution system can house utilities such as piping, electric, data, light fixtures. Provides quick and easy access to services while providing superior flexibility, by keeping the work surface open to accommodate equipment and procedures.

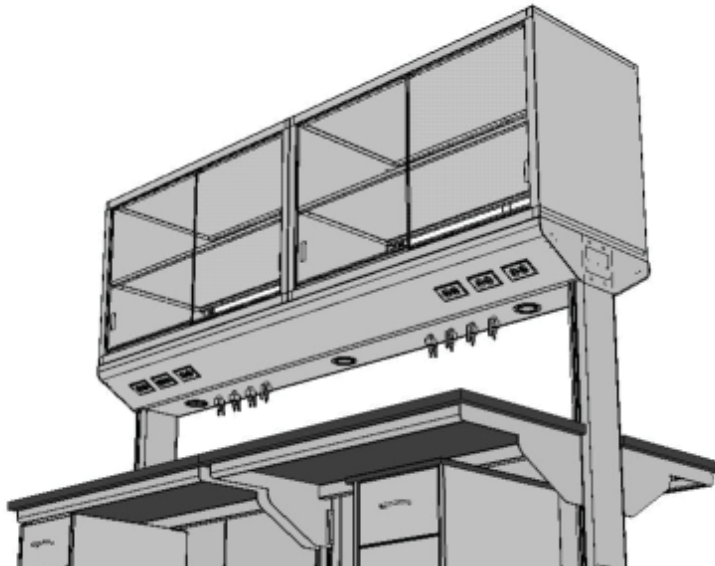

**Bottom Views**

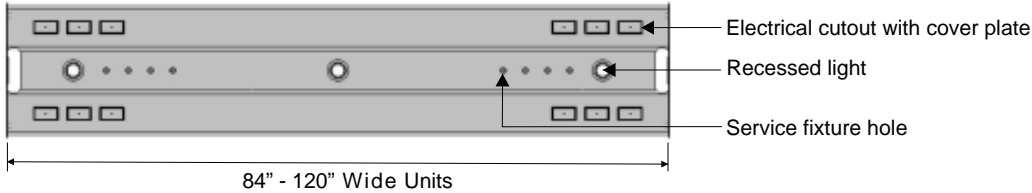
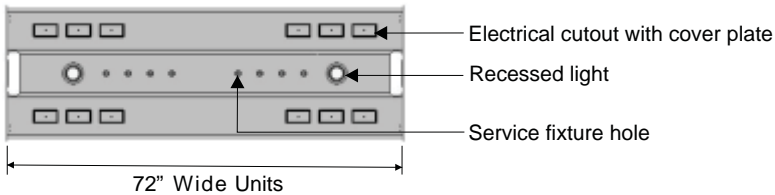
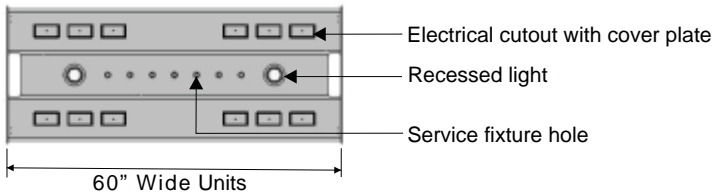

**Side View with End Cap**

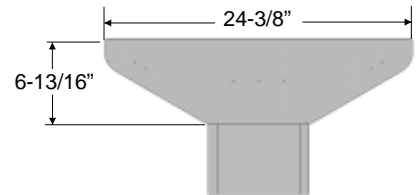

Typical Bottom Views for 132" & 144" Wide Units available upon request.

*SIGMA FUSION™*  
*ISLAND ASSEMBLIES*

**Island Single Core Assemblies**



Width	Item Number
48"	CAS1048
60"	CAS1060
72"	CAS1072

- Island Single Core assembly is 62" high by 8" deep and comes complete with cantilevered table frames, height adjustable in 1" increments (work surface not included).
- Overall depth of core is 54" deep with 23" deep table frame (does not include work surface).
- Complete with hanging rails to suspend lower cabinets.
- To order suspended base cabinets, mobile cabinets and wall cabinets refer to the catalog sections.
- Shipped assembled.
- Wall cabinets (single or double sided) must be ordered with option code "FM" to mount on Sigma Fusion™ (special mounting provisions must be made).

Typical Sigma Fusion™ work top for Island Single Core Assembly.

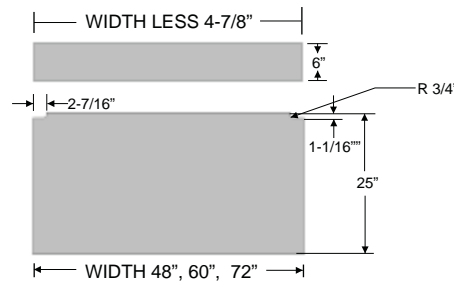

**Island Double Core Assemblies**

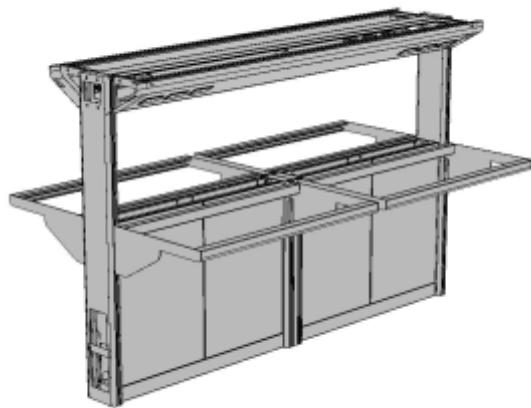

Width	Item Number
96"	CAS2096
108"	CAS2054
120"	CAS2060
132"	CAS2066
144"	CAS2072

- Island Double Core assembly is 62" high by 8" deep and comes complete with cantilevered table frames, height adjustable in 1" increments (work surface not included).
- Complete with hanging rails to suspend lower cabinets.
- To order suspended base cabinets, mobile cabinets and wall cabinets refer to the catalog sections.
- Overall depth of core is 54" deep with 23" deep table frame (does not include work surface).
- Shipped assembled.
- Wall cabinets (single or double sided) must be ordered with option code "FM" to mount on Sigma Fusion™ (special mounting provisions must be made).

Typical Sigma Fusion™ work top for Island Double Core Assembly.

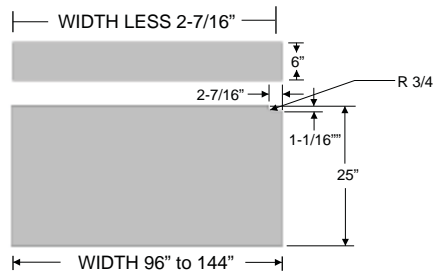

*SIGMA FUSION™*  
*COMPONENTS*

**Fusion™ Post Cover Panel**



**Item Number**

CSM0001

- Single cover panel used to cover exposed end of Sigma Fusion™ post.
- Cover slides on for easy installation.

**Fusion™ Carrier End Cap**



**Item Number**

CSM1001

- Single end cover cap used to enclose uncovered ends of Sigma Fusion™ overhead service carrier assembly.
- Suitable for Sigma Fusion™ only.

**Fusion™ Connector Plate**

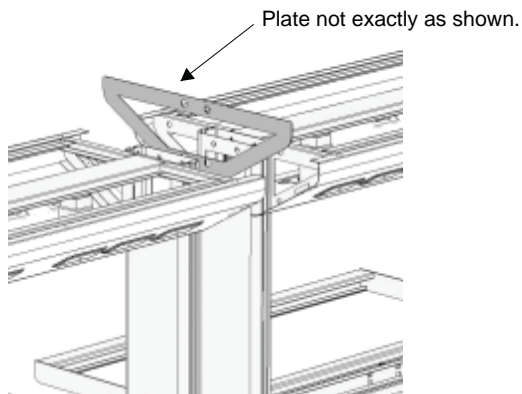

**Item Number**

CSM2001

- Plate used to join Sigma Fusion™ assemblies end to end.
- Mounting hardware not included.
- Suitable for Sigma Fusion™ only.
- Drawing not exactly as shown

*SIGMA FRAME™*  
*ADAPTABLE LABORATORY SYSTEMS***Why A Sigma Frame™ System?****Adaptable**

Using standard components, a wide variety of bench and service strip configurations can be readily constructed for any task. Create bench setups for a specific task, then modify it for the next application.

**Strong**

A strong and ridged 1-5/8" square bench system that looks just right. Benches are fully supported with inset front legs to minimize vibration. Especially good for heavy or delicate equipment setups.

**Productive**

Adjustable bench work surfaces are ergonomically designed to be fully height adjustable for a wide variety of laboratory personnel. Cabinets are easily interchangeable using a special cabinet dolly to keep equipment readily at hand.

**Affordable**

An economic solution to get a laboratory up and running by first installing the laboratory work surface and cabinets for sinks and chemical storage. Later, additional cabinets are added as required, or existing cabinets are moved to a new location.

**Mott's adaptable bench system provides a wide range of laboratory layout solutions. Using standard components it is easy to construct :**

- Perimeter ledge
- Island and peninsula service ledge
- Fixed height wall and island benches
- Double and single side island benches
- Adjustable wall and Island benches
- Individually adjustable work surfaces
- Movable lower storage cabinets that slide easily into place on support rails
- Overhead storage utilizing adjustable shelving
- Post mounted upper storage cabinets for island benches
- Reagent racks
- Service drops with removable access covers
- Full range of suspended cabinetry including sink cabinets, acid and solvent storage
- Chemical resistant paint finishes
- Wide selection of counter top materials available

**For additional information and help in planning contact Mott Manufacturing.**

*SIGMA FRAME™  
ADAPTABLE LABORATORY SYSTEMS*

**Construction Details**

Each bench system is fabricated from prime quality furniture grade cold rolled steel. All components are die formed to create a rigid interlocking structure. All services are fully accessible through removable cover panels; no special assembly tools are required. Bench legs come in two styles - fixed height or fully adjustable. All legs have a 3/8" diameter leveler bolt.

Suspended cabinets are interchangeable, and can be easily moved from workstation to workstation.

Shelf brackets are fully adjustable on 1" increments and are excellent for mounting a wide variety of shelving materials.

**Material Gauges**

- Service Panels, End Covers, Shelves 18 gauge
- Frames, Posts, Shelf Brackets 16 gauge
- Support Rails 14 gauge
- Structural Brackets 11 gauge

Typical Elevations

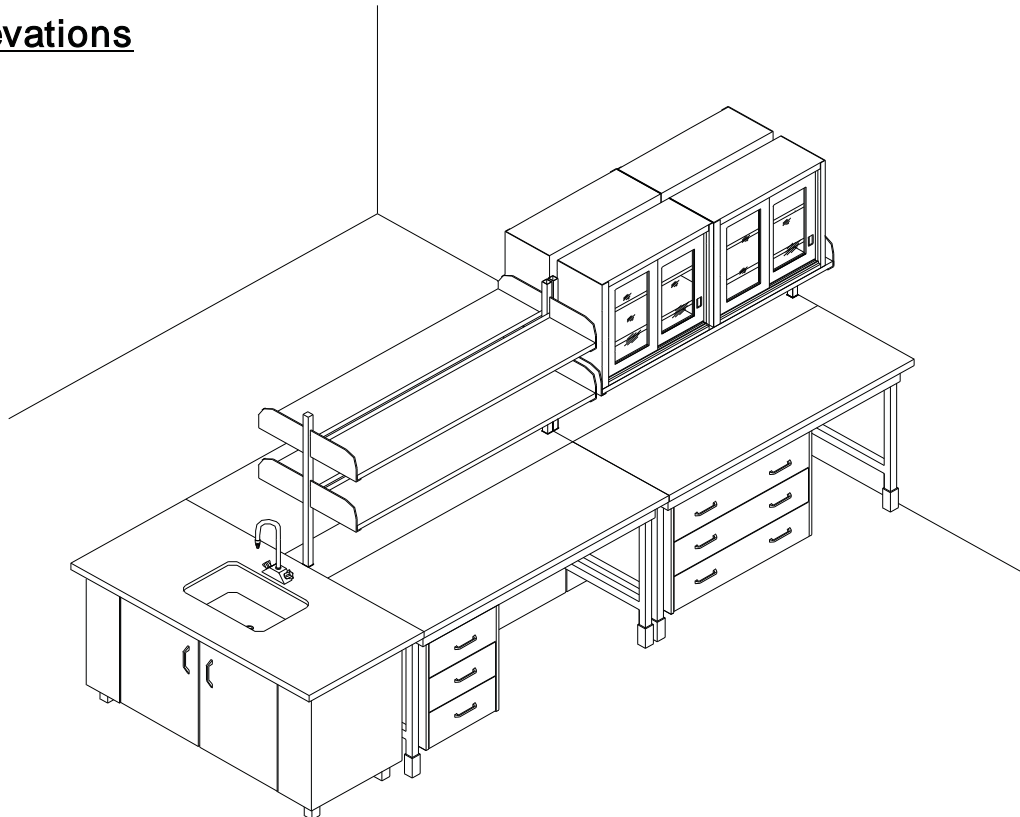





*SIGMA FRAME™*  
*ASSEMBLY COMPONENTS*

**Wall Assembly**

**Parts List:**

- 1) Horizontal Wall Channel
- 2) "L" Bracket
- 3) Base Plates
- 4) Uni-Channel
- 5) Leg Frame
- 6) Extended Front Rail
- 7) Rear Support Rail
- 8) Service Cover Support
- 9) "U" Bracket

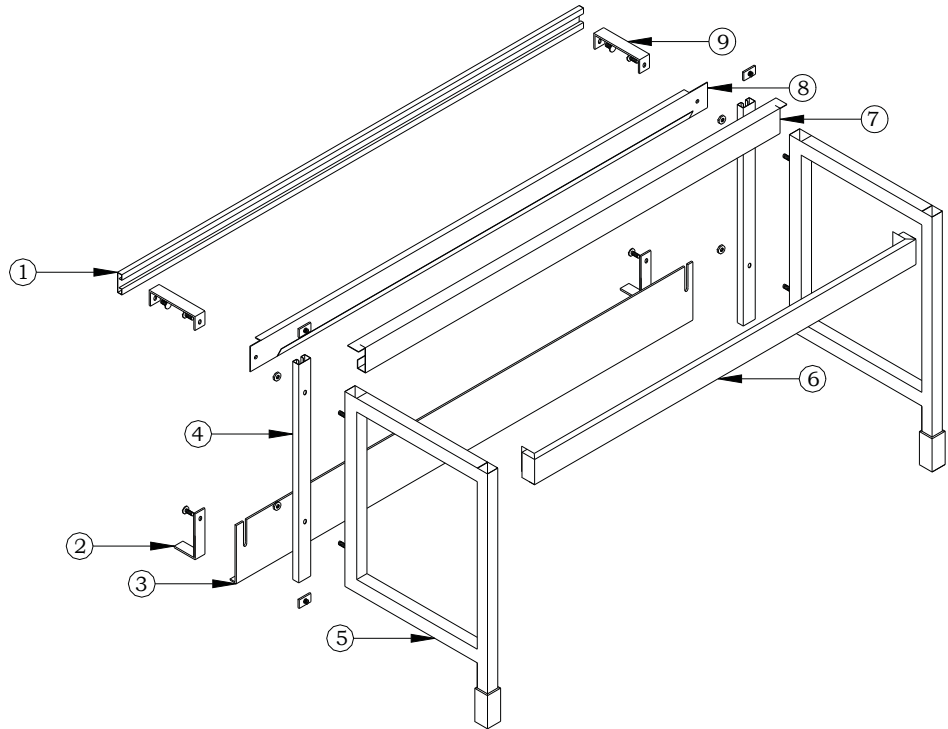

**Island Assembly**

**Parts List:**

- 1) Uni-Channel
- 2) Base Plates
- 3) Box Brackets
- 4) Leg Frame
- 5) Extended Front Rail
- 6) Rear Support Rail
- 7) "U" Bracket
- 8) Service Cover Support

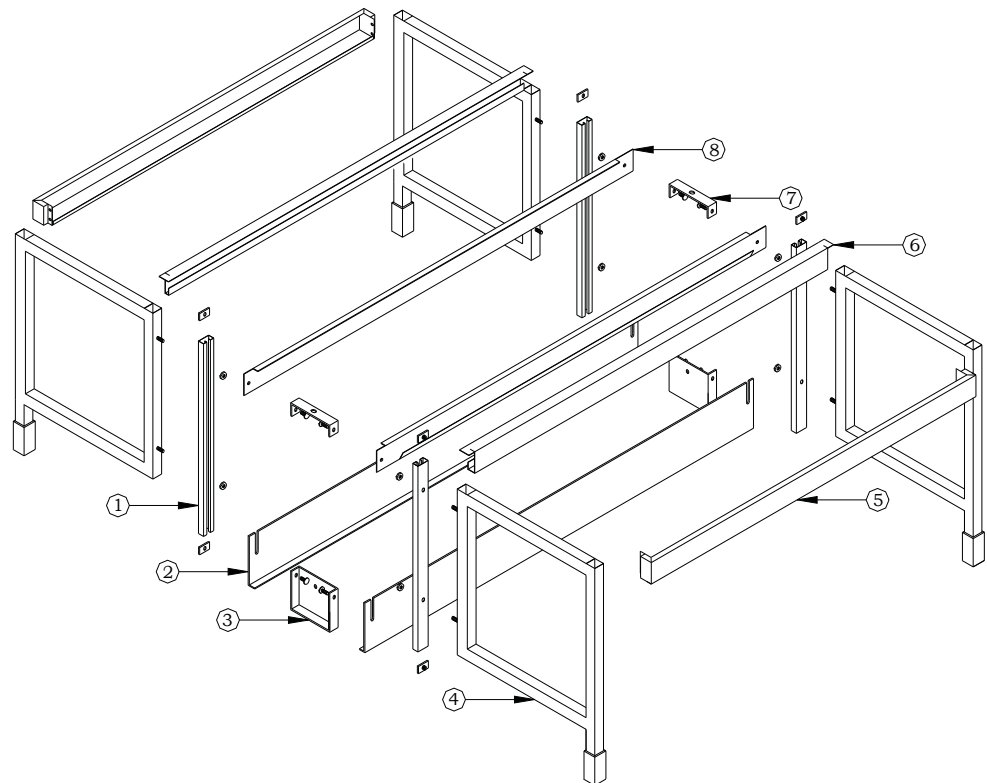

*SIGMA FRAME™*  
COMPONENTS

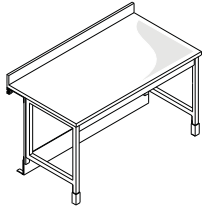

**Original Lateral Support Rails**

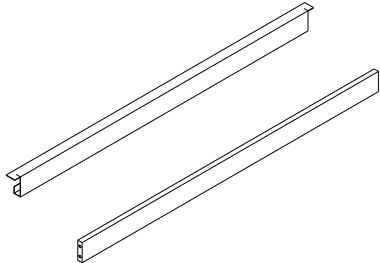

Width	Item Number
24"	LSR0024
36"	LSR0036
48"	LSR0048
60"	LSR0060
98"	LSR0098
513mm	LSR000A
1000mm	LSR000B
1500mm	LSR000C
2000mm	LSR000D

**Service Strip Units**

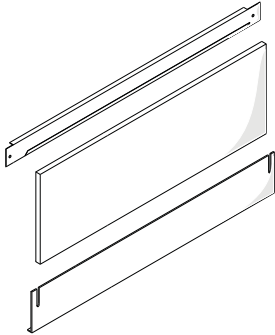

Width	Sitting Hgt	Standing Hgt
24"	SSA2024	SSA1024
36"	SSA2036	SSA1036
48"	SSA2048	SSA1048
60"	SSA2060	SSA1060
500mm	SSA200A	SSA100A
1000mm	SSA200B	SSA100B
1500mm	SSA200C	SSA100C
2000mm	SSA200D	SSA100D

- Nominal width.
- Available in sitting height (28-3/4") or standing height (34-3/4").

**Service Cover Strips**

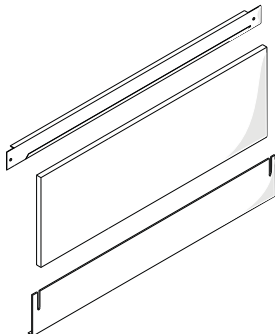

Width	Standing Hgt	41" High
24"	ASA1024	ASA3024
36"	ASA1036	ASA3036
48"	ASA1048	ASA3048
60"	ASA1060	ASA3060
500mm	ASA100A	ASA300A
1000mm	ASA100B	ASA300B
1500mm	ASA100C	ASA300C
2000mm	ASA100D	ASA300D

- Used with adjustable wall assemblies, adjustable island assemblies and adjustable legs.
- Available in standing height (34-3/4") and 41" high.

**Fixed Leg Assemblies**

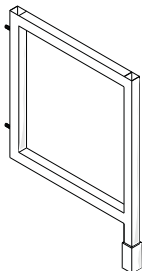

Depth	Sitting Hgt	Standing Hgt
21"	LFA2100	LFA1100
23"	LFA2500	LFA1500

- 21" depth provides 3" of counter top overhang.
- 23" depth provides 1" of counter top overhang.
- Available in sitting height (28-3/4"), and standing height (34-3/4").

*SIGMA FRAME™  
COMPONENTS*

**Adjustable Leg Assembly**

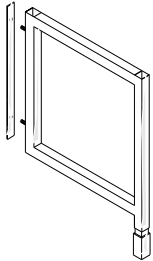
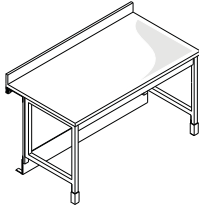

Depth	Item Number
21"	ALF1100

- Leg is adjustable from sitting height (28-3/4") to standing height (34-3/4").

**Vertical Wall Assemblies**

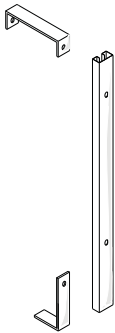

Height	Item Number
34 - 3/4"	VWA1100
28 - 3/4"	VWA2100

- Each assembly requires 3/8" spring nuts and bolts.
- Available in sitting height (28-3/4"), and standing height (34-3/4").

**Vertical Island Assemblies**

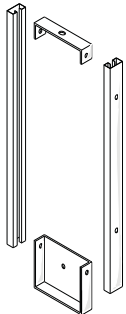

Height	Item Number
34 - 3/4"	VIA1100
28 - 3/4"	VIA2100

- Each assembly requires 3/8" spring nuts and bolts.
- Available in sitting height (28-3/4"), and standing height (34-3/4").

**Adjustable Vertical Wall Assemblies**

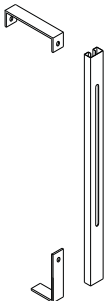

Height	Item Number
34 - 3/4"	AWA1100
41"	AWA3100

- Each assembly requires 3/8" spring nuts and bolts.
- Available in sitting height (28-3/4"), and 41" high.

*SIGMA FRAME™*  
*COMPONENTS*

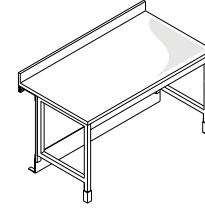

**Adjustable Vertical Island Assemblies**

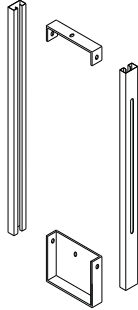

Height	Item Number
34 - 3/4"	AIA1100
41"	AIA3100

- Each assembly requires 3/8" spring nuts and bolts.
- Available in sitting height (28-3/4"), and standing height (34-3/4").

**Vertical Post Assemblies**



Height	Item Number
34 - 3/4"	CPA1084
28 - 3/4"	CPA2084
41"	CPA3084

- Each assembly requires 3/8" spring nuts and bolts.
- Post assembly have an overall height of 84".

**Steel Shelves For Vertical Post Assemblies**

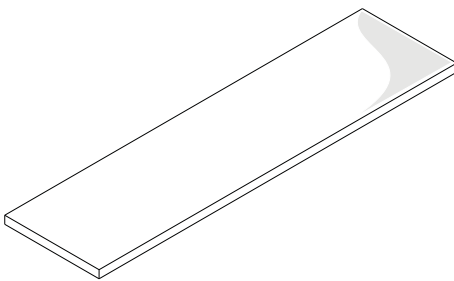

Width	10" Deep	12" Deep	14" Deep	16" Deep
24"	LFS1024	LFS1224	LFS1424	LFS1624
30"	LFS1030	LFS1230	LFS1430	LFS1630
36"	LFS1036	LFS1236	LFS1436	LFS1636
42"	LFS1042	LFS1242	LFS1442	LFS1642
48"	LFS1048	LFS1248	LFS1448	LFS1648
60"	LFS1060	LFS1260	LFS1460	LFS1660
513mm	LFS100A	LFS120A	LFS140A	LFS160A
1000mm	LFS100B	LFS120B	LFS140B	LFS160B
1500mm	LFS100C	LFS120C	LFS140C	LFS160C
2000mm	LFS100D	LFS120D	LFS140D	LFS160D

- Only suitable for use with Vertical Post Assemblies.
- Nominal width.
- Shelves only suitable for Sigma Frame™ and WPA components.
- Add 1" angles to shelves by using option codes:
  - AR (Rear Shelf Angle welded to shelf)
  - AF (Front Shelf Angle welded to shelf)
  - AB (Rear and Front Shelf Angle welded to shelf)

**Rear Support Rails**

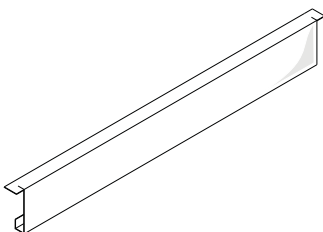

Width	Item Number
24"	RSR0024
36"	RSR0036
48"	RSR0048
60"	RSR0060
513mm	RSR000A
1000mm	RSR000B
1500mm	RSR000C
2000mm	RSR000D

- Nominal widths.

*SIGMA FRAME™*  
COMPONENTS

**Service Cover Supports**

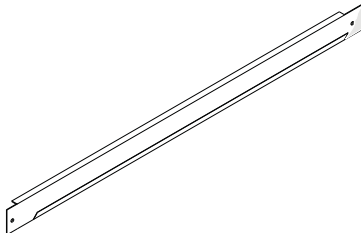
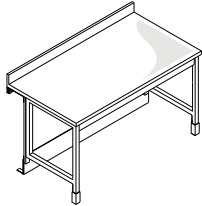

Width	Item Number
24"	SCS0024
36"	SCS0036
48"	SCS0048
60"	SCS0060
513mm	SCS000A
1000mm	SCS000B
1500mm	SCS000C
2000mm	SCS000D

- Nominal width.

**Base Plates**

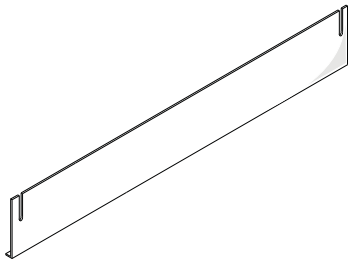

Width	Item Number
24"	BPA0024
36"	BPA0036
48"	BPA0048
60"	BPA0060
513mm	BPA000A
1000mm	BPA000B
1500mm	BPA000C
2000mm	BPA000D

- Nominal width.

**Removable Service Cover Panels**

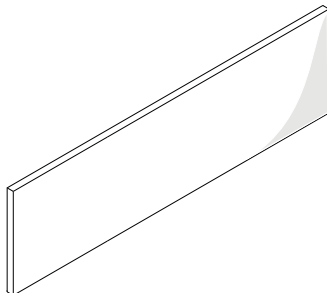

Width	Sitting Hgt	Standing Hgt	18" Hgt
24"	RSC2024	RSC1024	RSC3024
36"	RSC2036	RSC1036	RSC3036
48"	RSC2048	RSC1048	RSC3048
60"	RSC2060	RSC1060	RSC3060
513mm	RSC200A	RSC100A	RSC300A
1000mm	RSC200B	RSC100B	RSC300B
1500mm	RSC200C	RSC100C	RSC300C
2000mm	RSC200D	RSC100D	RSC300D

- Nominal width.
- Available in sitting height (28-3/4"), standing height (34-3/4"), and 18" high.

**Adjustable Service Cover Support Rails**

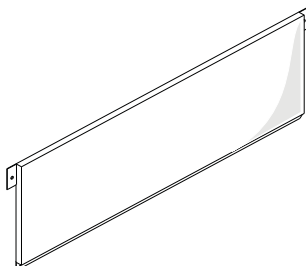

Width	Standing Hgt	41" High
24"	ACP1024	ACP3024
36"	ACP1036	ACP3036
48"	ACP1048	ACP3048
60"	ACP1060	ACP3060
513mm	ACP100A	ACP300A
1000mm	ACP100B	ACP300B
1500mm	ACP100C	ACP300C
2000mm	ACP100D	ACP300D

- Nominal width.
- Available in standing height (34-3/4"), and 41" high.

*SIGMA FRAME™*  
COMPONENTS

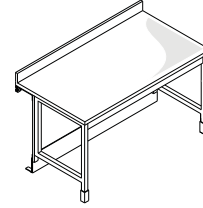

**Front Support Rails**

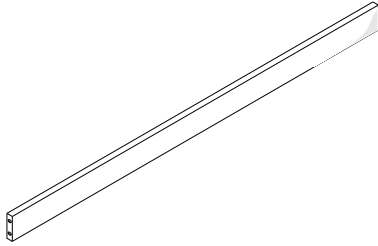

Width	Item Number
24"	FSR0024
36"	FSR0036
48"	FSR0048
60"	FSR0060
513mm	FSR000A
1000mm	FSR000B
1500mm	FSR000C
2000mm	FSR000D

- Nominal width.

**Vertical Uni-Channels**



Height	Item Number
34 - 3/4"	VLC1000
28 - 3/4"	VLC2000

- Nominal width.
- Available in sitting height (28-3/4"), and standing height (34-3/4").

**Slotted Vertical Channels**

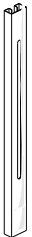

Height	Item Number
34 - 3/4"	VSC1000
28 - 3/4"	VSC3000

- Nominal width.
- Available in sitting height (28-3/4"), and standing height (34-3/4").

**Service Legs**

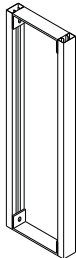

Height	Item Number	Depth
34 - 3/4"	SLG1007	7"
28 - 3/4"	SLG2007	7"
34 - 3/4"	SLG1014	14"
28 - 3/4"	SLG2014	14"

- Nominal width.
- Each assembly requires 3/8" spring nuts & bolts.
- Available in sitting height (28-3/4"), and standing height (34-3/4").

**Horizontal Wall Channel**

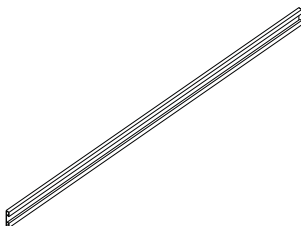

Length	Item Number
84"	HWC0084



*SIGMA FRAME™*  
*MISCELLANEOUS COMPONENTS*

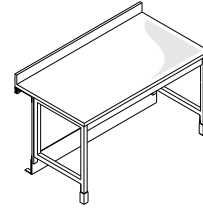

**"L" Bracket**

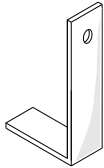

Height	Item Number
9 - 1/2"	LBK0000

**"U" Bracket**

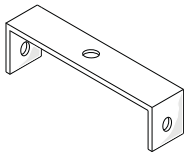

Width	Item Number
6"	UBW0000
12"	UBI0000

- Nominal width.

**Box Bracket**

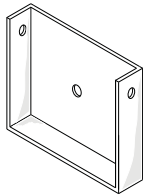

Width	Item Number
12"	BBK0000

- Nominal Service Core width.

**Double Angle Sleeves**

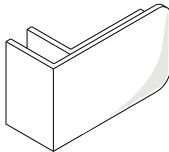

Length	Item Number
3 3/4"	DAG000F
3"	DAG0003
2"	DAG0002

**Leg Frame End Filler**

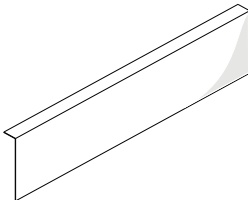

Length	Item Number
21"	LEF0021

**Cabinet Installation Dolly**

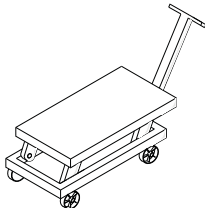

Tools	Item Number
DOLLY	CAR0000

*SIGMA FRAME™  
MISCELLANEOUS COMPONENTS*

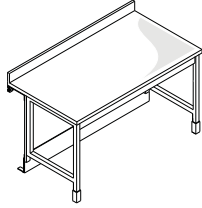

**End Sink Unit**

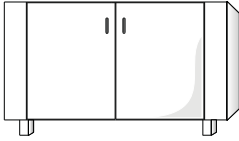

Description	54" Wide	58" Wide
Full Door Unit	9900058	9900060
False Panel Unit	9900059	9900061

- Full door model shown.
- Comes with finished back containing 10" wide center access opening.

**Sigma Frame™ Wall Cabinet Hanger Rails**

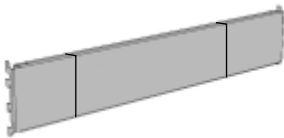

Telescoping Wall Cabinet Hanger Rail



Fixed Width Wall Cabinet Hanger Rail

Width	Telescoping Rail	Fixed Width Rail
24"	AWR0024	SWR0024
30"	AWR0030	SWR0030
36"	AWR0036	SWR0036
42"	AWR0042	SWR0042
48"	AWR0048	SWR0048
54"	AWR0054	SWR0054
60"	AWR0060	SWR0060
72"	AWR0072	SWR0072

- Sigma Frame™ Wall Cabinet Hanger Rails are required to hang above-counter storage cabinets on to Sigma Frame™ systems.
- Order rails to match width of support structure frame (Telescoping Rails are not suitable for cabinets smaller than 24" wide).
- Telescoping Rail is adjustable up to 5".
- Wall cabinets must be ordered with option code "HR" to suspend from Sigma Frame™ systems. See wall cabinet section to order cabinets.

**Open Support Legs**

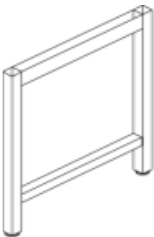

- Open Support Legs are used to support countertops where base cabinets are not required.
- Leveling bolts and PVC boots are included.
- Available in sitting height (28-3/4"), ADA height (31-3/4") and standing height (34-3/4").
- 1-5/8" wide.
- Suitable for Sigma Frame components.

Depth	Sitting Hgt	Standing Hgt	ADA Hgt
22"	LFH2022	LFH1022	LFH5022
23"	LFH2023	LFH1023	LFH5023
28"	LFH2028	LFH1028	LFH5028
29"	LFH2029	LFH1029	LFH5029
35"	LFH2035	LFH1035	LFH5035

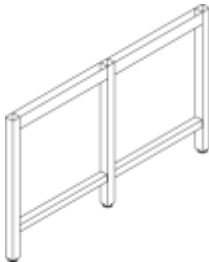

- Open Support Legs are used to support countertops where base cabinets are not required.
- Leveling bolts and PVC boots are included.
- Available in sitting height (28-3/4"), ADA height (31-3/4") and standing height (34-3/4").
- 1-5/8" wide.
- Suitable for Sigma Frame components.

Depth	Sitting Hgt	Standing Hgt	ADA Hgt
46"	LFH2046	LFH1046	LFH5046
52"	LFH2052	LFH1052	LFH5052
58"	LFH2058	LFH1058	LFH5058

**Table Legs**



- Table Legs are used to support countertops where base cabinets are not required.
- Leveling bolts and PVC boots are included.
- Available in sitting height (28-3/4"), ADA height (31-3/4") and standing height (34-3/4").
- 1-5/8" X 1-5/8" tube.

Height	Item Number
28-3/4"	2200000
34-3/4"	2100000
31-3/4"	2500000

All dimensions and sizes shown are nominal. Specifications and details are based on product information at the time of printing and may change at any time without notice. Mott Manufacturing reserves the right to change dimensions, specifications and manufacturing details at any time without notice.

**SIGMA FRAME™**  
**SIGMA FRAME™ WALL PILASTERS BRACKETS & SHELVES**

**Sigma Frame™ Wall Pilaster**

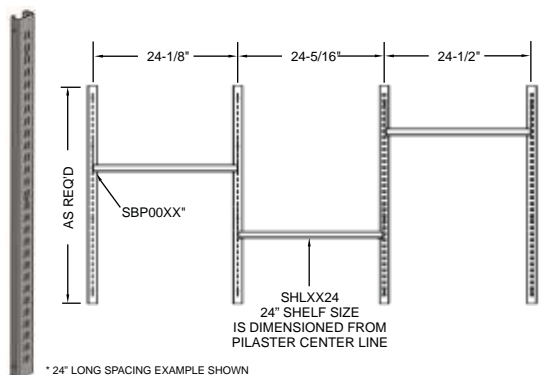

Height	Single Slotted	Double Slotted
18"	WPA1018	WPA0018
24"	WPA1024	WPA0024
30"	WPA1030	WPA0030
36"	WPA1036	WPA0036
42"	WPA1042	WPA0042
48"	WPA1048	WPA0048
60"	WPA1060	WPA0060
72"	WPA1072	WPA0072
84"	WPA1084	WPA0084
96"	WPA1096	WPA0096

- Pilasters only suitable for Sigma Frame™, Inverted Shelf Brackets, "SBP" and "WPA" components.
- Wall Pilasters should be mounted 1/2" on center wider than the shelf length.
- 1-5/8" wide by 13/16" deep.

**Sigma Frame™ Steel and Wood Shelves For Wall Pilasters**



- ∞ Shelves are actual widths.
- ∞ Add 1" angles to shelves by using option codes:
  - AR (Rear Shelf Angle welded to shelf)
  - AF (Front Shelf Angle welded to shelf)
  - AB (Rear and Front Shelf Angle welded to shelf)

Steel Shelves					
Width	10" Deep	12" Deep	14" Deep	16" Deep	18" Deep
24"	SHL1024	SHL1224	SHL1424	SHL1624	SHL1824
30"	SHL1030	SHL1230	SHL1430	SHL1630	SHL1830
36"	SHL1036	SHL1236	SHL1436	SHL1636	SHL1836
42"	SHL1042	SHL1242	SHL1442	SHL1642	SHL1842
48"	SHL1048	SHL1248	SHL1448	SHL1648	SHL1848
60"	SHL1060	SHL1260	SHL1460	SHL1660	SHL1860
513mm	SHL100A	SHL120A	SHL140A	SHL160A	SHL180A
1000mm	SHL100B	SHL120B	SHL140B	SHL160B	SHL180B
1512mm	SHL100C	SHL120C	SHL140C	SHL160C	SHL180C
2000mm	SHL100D	SHL120D	SHL140D	SHL160D	SHL180D



- Shelves are actual widths.
- Shelves are 1" thick.
- For wood shelving options see page N8.

Wood Shelves					
Width	10" Deep	12" Deep	14" Deep	16" Deep	18" Deep
24"	SHL1024W	SHL1224W	SHL1424W	SHL1624W	SHL1824W
30"	SHL1030W	SHL1230W	SHL1430W	SHL1630W	SHL1830W
36"	SHL1036W	SHL1236W	SHL1436W	SHL1636W	SHL1836W
42"	SHL1042W	SHL1242W	SHL1442W	SHL1642W	SHL1842W
48"	SHL1048W	SHL1248W	SHL1448W	SHL1648W	SHL1848W
60"	SHL1060W	SHL1260W	SHL1460W	SHL1660W	SHL1860W
513mm	SHL100AW	SHL120AW	SHL140AW	SHL160AW	SHL180AW
1000mm	SHL100BW	SHL120BW	SHL140BW	SHL160BW	SHL180BW
1512mm	SHL100CW	SHL120CW	SHL140CW	SHL160CW	SHL180CW

**Sigma Frame™ Shelf Brackets For Wall Pilasters**



- ∞ Brackets only suitable for Sigma Frame™ and "WPA" components.
- ∞ Pair of shelf brackets are 6" high.
- ∞ Add option code NN for no alignment tabs on SBP brackets.

Depth	Item Number
10"	SBP0010
12"	SBP0012
14"	SBP0014
16"	SBP0016
18"	SBP0018

**Sigma Frame™ Inverted Shelf Brackets For Wall Pilasters**



- ∞ Brackets only suitable for Reagent components.
- ∞ Pair of shelf brackets are 4-1/4" high.

Depth	Item Number
10"	SBP1010
12"	SBP1012
14"	SBP1014
16"	SBP1016
18"	SBP1018

## Mott Manufacturing Limited

### Steel Laboratory Furniture Warranty

Mott Manufacturing Limited and its subsidiaries (hereinafter "Mott"), 452 Hardy Road, Brantford, Ontario, Canada, N3T 5L8 warrants that the product manufactured by it shall be free from defects in material and/or workmanship for two (2) years from the date of shipment of the product to the Purchaser. If Mott acknowledges that any such defects found within the warranty period are the result of faulty material and/or workmanship, Mott's sole liability and the Purchaser's exclusive remedy shall be the repair and/or replacement, of the faulty product by Mott or its appointed agent, at Mott's expense, f.o.b. Mott factory. No product or parts thereof shall be returned to Mott or any of its dealers or agents without Mott's prior written consent. Product returned to Mott shall be shipped at buyers cost and risk of loss. Replacement product shall be returned at Mott's cost and risk of loss. In some cases Mott may elect to provide on-site repair of defective product and in these cases, Buyer agrees to allow Mott factory technicians or authorized representative reasonable and timely access to jobsite during normal business hours. Repairs or replacement of product under warranty does not extend the original warranty period. The foregoing warranty does not apply to defects resulting from faulty installation, operation, disassembly or remodeling, or from misuse, misapplication, neglect, abuse, accident, alteration, or the lack of proper maintenance, storage, cleaning, and care. Mott does not provide warranty on major components manufactured by others - only the original manufacturer's warranty applies.

THERE ARE NO OTHER WARRANTIES, EXPRESSED OR IMPLIED, WHICH EXTEND BEYOND THE FACE HEREOF INCLUDING, WITHOUT LIMITATION, WARRANTIES OF MERCHANTABILITY OR FITNESS FOR A PARTICULAR USE.

The liability and remedy set forth above, in the event of a breach by Mott of its warranties set forth above or any of the covenants or agreements relating to the sale of the products to the Purchaser, shall be the sole and exclusive remedy to the Purchaser. In no event shall Mott's liability exceed the amount paid, excluding installation, by the Purchaser to Mott or any of its dealers or agents for the products to which the breach applies.

In no event shall Mott be liable to the Purchaser for any consequential or indirect damages including, but not limited to, loss of income, revenue, or profits in the event of a breach of any of the warranties or other covenants made by Mott with respect to the sale of Mott products to the Purchaser.

The foregoing may not be modified except by a writing signed by Mott. The Purchaser, by accepting delivery of any product manufactured by Mott, hereby accepts the foregoing and expressly waives any other remedy and damages, direct, indirect, and consequential.

## Mott Manufacturing LLC

### Wood Laboratory Furniture Warranty

Mott Manufacturing LLC. and its subsidiaries (hereinafter "Mott"), 562 Industrial Park Road, Maxwelton, West Virginia, USA, 24957 warrants that the product manufactured by it shall be free from defects in material and/or workmanship for one (1) year from the date of shipment of the product to the Purchaser. If Mott acknowledges that any such defects found within the warranty period are the result of faulty material and/or workmanship, Mott's sole liability and the Purchaser's exclusive remedy shall be the repair and/or replacement, of the faulty product by Mott or its appointed agent, at Mott's expense, f.o.b. Mott factory. No product or parts thereof shall be returned to Mott or any of its dealers or agents without Mott's prior written consent. Product returned to Mott shall be shipped at buyers cost and risk of loss. Replacement product shall be returned at Mott's cost and risk of loss. In some cases Mott may elect to provide on-site repair of defective product and in these cases, Buyer agrees to allow Mott factory technicians or authorized representative reasonable and timely access to jobsite during normal business hours. Repairs or replacement of product under warranty does not extend the original warranty period. The foregoing warranty does not apply to defects resulting from faulty installation, operation, disassembly or remodeling, or from misuse, misapplication, neglect, abuse, accident, alteration, or the lack of proper maintenance, storage, cleaning, and care. Mott does not provide warranty on major components manufactured by others - only the original manufacturer's warranty applies.

THERE ARE NO OTHER WARRANTIES, EXPRESSED OR IMPLIED, WHICH EXTEND BEYOND THE FACE HEREOF INCLUDING, WITHOUT LIMITATION, WARRANTIES OF MERCHANTABILITY OR FITNESS FOR A PARTICULAR USE.

The liability and remedy set forth above, in the event of a breach by Mott of its warranties set forth above or any of the covenants or agreements relating to the sale of the products to the Purchaser, shall be the sole and exclusive remedy to the Purchaser. In no event shall Mott's liability exceed the amount paid, excluding installation, by the Purchaser to Mott or any of its dealers or agents for the products to which the breach applies.

In no event shall Mott be liable to the Purchaser for any consequential or indirect damages including, but not limited to, loss of income, revenue, or profits in the event of a breach of any of the warranties or other covenants made by Mott with respect to the sale of Mott products to the Purchaser.

The foregoing may not be modified except by a writing signed by Mott. The Purchaser, by accepting delivery of any product manufactured by Mott, hereby accepts the foregoing and expressly waives any other remedy and damages, direct, indirect, and consequential.

*APPENDIX A - REVISION HISTORY*

Version	Release Date	Author	Section/Pages Affected	Description of Change
1.0	January 2003	T. Lehigh	All	Initial Release
2.0	April 2004	T. Lehigh	F36, I section, Index	Add Fume Hood Double Sided Furring Panels, relocate some items to Miscellaneous section, update Index
3.0	August 2004	T. Lehigh	A3, B1, C section, D1, E4, E20, E21, F33, G14, G16, H13, I14, Index	Additional widths to drawer units, corrections to drawings and product numbers throughout Floor Cabinets section, relocate and add information page on O.R. Cabinets to Specialty Cabinets section, correct product numbers and add additional widths or length
4.0	April 2006	J. Dolan	All	Revision of all sections in the catalog
4.1	June 2006	J. Dolan	A3, A23, C7, D1, E15-17, E20, G2, G7, G9, F30-34, F40, H15, H17, H18, H23, H25, X5	Corrections to drawings, written product information and product numbers. Additional widths or lengths added.
4.2	July 2006	J. Dolan	B19, D1-D7, E1, E2, E4, E5, E7, E9, E11, E14-18, G3, G7, F21, F23, F28, J3, X4	Written product information
4.3	January 2007	J. Dolan	F13 - F25, F28 - F35, H18	Corrections to drawings and/or notes added to pages F13 - F25, F28 - F35. Change of product number on H18.
5.0	November 2008	J. Dolan	All	Revision of all sections in the catalog
5.1	February 2009	J. Dolan	Table of Contents, A13, A16, A29, G9, H15-H18, all of N section (Optima), all of F section (fume hoods)	Corrections to drawings, written product information and product numbers. Additional widths or lengths added.
5.2	July 2009	J. Dolan	Introduction, A29, B20, D1, E1, E4, E7, E9, E11, F23, F29, F33-F35, F39, F40, G21, H15-18, J5, N21, X6, X7 WOOD	Corrections to drawings, written product information and product numbers. Additional widths or lengths added.
6.0	October 2009	J. Dolan K. Dabrowski	All	Revision of all sections in the catalog. Addition of wood casework sections.
6.1	February 2010	J. Dolan	A8, B3, B5-7, B18, C18, E1-4, E10-12, E18, F5-6, G6, G18, H9, I26, L1-3, L8-9, M5-6, P11-12, P15-16, P19, P22-25, P29-33, P35, P37, P45, R19, R21, S4-5, S7, S9, S17, S19-20, U11	Corrections to drawings, written product information and product numbers.
7.0	September 2011	J. Dolan N. Hawley	All	Revision of all sections in the catalog
8.0	December 2013	J. Dolan N. Hawley	All	Revision of all sections in the catalog